

# INDEX

<b><u>INTRODUCTION</u></b>	<b><u>PAGE</u></b>	<b><u>DESCRIPTION</u></b>
KEP Company Overview	3	A brief history of our company.
<b><u>COMPARISON TABLES</u></b>	<b><u>PAGE</u></b>	<b><u>DESCRIPTION</u></b>
Product vs. Flow Meter Compatibility Table	4	Product comparison based on flowmeter compatibility
Product vs. Feature Table	5	Product comparison based on feature availability
<b><u>SIGNAL CONDITIONERS</u></b>	<b><u>PAGE</u></b>	<b><u>DESCRIPTION</u></b>
Signal Conditioners Tutorial	6	A quick overview for signal conditioners.
SC-FI	7	Frequency to current signal conditioner.
SC-II	9	Current to current isolator.
SC-IF	11	Current to frequency loop powered isolator.
SC-FF	13	Frequency to frequency pulse isolator and scaler.
AMP-1-N	15	Preamplifier and signal conditioner for NAMUR sensors.
<b><u>PROCESS, LEVEL &amp; TEMP. MONITORS</u></b>	<b><u>PAGE</u></b>	<b><u>DESCRIPTION</u></b>
Process, Level & Temp. Monitors Tutorial	16	A quick overview for process and level monitors.
529K	42	LED, Miniature, Analog Input Rate/Process Indicator.
531K	17	LED, Miniature, Temperature Indicator with RTD input.
532K	18	LED, Miniature, Temperature Indicator with Thermocouple input.
TP550 Series	19	Temperature/process monitor with or without alarms.
INTELLECT-69PM2	21	Analog input, LED, panel meter with relays & 4-20mA output.
SQUIRT-R	23	Loop powered indicator with LCD display.
LEVELtrol II	25	Multi-Function Level Indicator and Controller.
<b><u>FIELD INDICATORS</u></b>	<b><u>PAGE</u></b>	<b><u>DESCRIPTION</u></b>
Field Indicators Tutorial	27	A quick overview for field indicators.
SQUIRT	28	Loop powered Ratemeter / Totalizer with LCD display.
BAT R/T Millennium	31	New & Improved, Battery powered Ratemeter / Totalizer with LCD display and 20 point Linearization.
BAT RAT Millennium	34	Special version of the BAT R/T Millennium with transistor alarm output.
BAT D/T Millennium	37	Special version of the BAT R/T Millennium with dual totalizer display.
<b><u>RATEMETER / TOTALIZERS</u></b>	<b><u>PAGE</u></b>	<b><u>DESCRIPTION</u></b>
Rate / Total Tutorial	40	A quick overview for rate / total monitors.
130K	41	Battery Powered Totalizer with LCD Display
525K, 529K & 530K	42	LED, Miniature, Pulse and Analog Input Rate and Total Indicator
INTELLECT69	43	LED, 1/8 DIN, Analog Input Ratemeter / Totalizer with scaling and relays.
MINITROL	45	LED, 1/8 DIN, pulse input, Ratemeter / Totalizer with scaling and relays.
MINITROL-S	48	Special version of the MRT with separate scaling for rate and total.
MINITROL-PW	50	Special version of the MRT for use with paddle or pelton wheel turbine flowmeters.
DRT	51	Separate Dual Ratemeter and Totalizer with Combination Function.
SUPERtrol ILE	53	Rate/Total indicator for pulse inputs.
SUPERtrol-I	67	Rate/Total indicator with pulse or analog inputs.
KEPtrol R/T	55	Performs Volumetric, Mass or Corrected Volume Batching. 8 Digit, LED, Scalable Ratemeter / Totalizer with Pulse or Analog Inputs.
RTP	58	Two Separate Ratemeter, Totalizers with 2-Line LCD Display
MS-716	60	Flow Totalizer, Ratemeter and Batchers for Vehicle & Skid Mounting.

# INDEX

(continued)

<b><u>BATCHERS</u></b>	<b><u>PAGE</u></b>	<b><u>DESCRIPTION</u></b>
Batcher Tutorial	64	A quick overview for batchers.
MINIBATCHER	65	Low cost, miniature batch controller with pulse input.
SUPERtrol ILE	53	Batch controller indicator for pulse inputs.
SUPERtrol-I	67	Batch controller indicator with pulse or analog inputs. Performs Volumetric, Mass or Corrected Volume batching.
BATCHtrol II	70	Batch controller with pulse or analog inputs.
MS-716	60	Flow Totalizer, Ratemeter and Batcher for Vehicle & Skid Mounting.
FLOWtrol	108	Batch controller with two DPDT relay outputs
MASSbatch	109	Batch controller with Temperature/Density compensation
<b><u>FLOW COMPUTERS</u></b>	<b><u>PAGE</u></b>	<b><u>DESCRIPTION</u></b>
Flow Computer Tutorial	73	A quick overview for flow computers.
SUPERtrol-I	67	Batch controller, Rate/Total indicator with pulse or analog inputs. Performs Volumetric, Mass or Corrected Volume batching.
SUPERtrol-II	75	Multifunction flow computer, compensates steam, gases and liquid for temperature & pressure to yield Volumetric, Mass & Heat Flow.
MS-748	78	Rugged, Field Mount, Multi-Function Flow Computer.
ES-747	82	Flow Computer for Liquid and Gas Applications.
MASStrol	86	Mass flow computer, compensates steam, gases and liquids for temperature and pressure to yield Volumetric, Mass & Heat Flow.
DPFC	89	Differential pressure flow computer, used for stacked DP configurations, compensates steam, gases and liquids for temp. and pressure to yield Volumetric, Mass & Heat Flow.
<b><u>COMMUNICATION SOLUTIONS</u></b>	<b><u>PAGE</u></b>	<b><u>DESCRIPTION</u></b>
Communication Solutions Tutorial	92	A quick overview for communication solutions.
KEPServer (KEPS-KEP1-32)	93	SUPERtrol series 32 bit device driver for KEPware's DDE Server.
TROLlink	94	Remote metering and data collection software
IEPS 1000	96	Intelligent Ethernet Port Server - Single Port.
IEPS 3000	97	Intelligent Ethernet Port Server - Up to 4 Ports.
CA-285	98	RS-422/485 to RS-232 Interface Converter.
MPP-2400	99	Port Powered Modem, 2400 Baud Rate.
MS-722	100	Wall Mount Port Powered Modem.
MPP-2400N	101	Port Powered Modem, 2400 Baud Rate in NEMA4 enclosure.
TWP	102	Industrial Two Way Pager Wireless Data Transceiver.
<b><u>FACTORY AUTOMATION</u></b>	<b><u>PAGE</u></b>	<b><u>DESCRIPTION</u></b>
Factory Automation Tutorial	103	A quick overview for factory automation.
Infilink-HMI	104	Industrial Automation Software.
KEPServerEX	107	OPC/DDE Server Software.
<b><u>SPECIAL FLOW INSTRUMENTS</u></b>	<b><u>PAGE</u></b>	<b><u>DESCRIPTION</u></b>
FLOWtrol	108	Batch Controller with DPDT relays.
KEPtrol F/C	108	Net rate & total display, ideal for net flow of boiler or diesel fuel.
MASSBATCH	109	Batch controller with Temperature or Density Compensation.
<b><u>ACCESSORIES</u></b>	<b><u>PAGE</u></b>	<b><u>DESCRIPTION</u></b>
XTROL 7/4	110	Explosion proof housing for standard 'trol products.
XHV	112	Explosion proof housing for viewing displays (Supertrols, MRT, INT69, etc) in hazardous areas.
NEMATROL	113	Wall mountable NEMA 4X Enclosures.
LCN4X	114	Low Cost NEMA 4X Wall mountable Enclosures.
E200	115	Outdoor Enclosure for 1/32 DIN units
P1000	116	Table top / hand held serial printer.
P295	117	Miniature Slip Printer.
115 Series	118	5, 12 and 24 VDC power supplies with 115 or 230 VAC input.
AMP-1	118	Preamp and signal conditioner for magnetic pickups.
SPARE PARTS	119	Various retrofit boards, IC chips, fuses and spare parts.

# KEP Company Overview

## **Introduction**

Kessler Ellis Products has manufacturing facilities located in Eatontown, New Jersey. KEP has been supplying display and instrumentation products since it was founded in 1960. In the early 80's, KEP broadened its product line to include flow measurement instrumentation. As the market for instrumentation continued to evolve, product offerings grew to include industrial automation, communication server software, communications accessories, and Industrial PC's.

## **People**

KEP team members have consistently shown an obsessive concern about our customers for the last 40 years. We work hard to offer you solutions that solve your problems and service your needs. We take that extra step to ensure complete customer satisfaction.

## **Flow Measurement Community**

KEP seeks to service the flow measurement community by providing versatile, economical instrumentation and "know how" to our users. Our goal is to enable you to select a suitable instrument from our offerings for use with a flowmeter selected from any supplier of your choice from the broad range of flowmeter types and suppliers on the market today.

## **Flowmeter Compatibility**

There are a large number of flowmeter types in the market which are compatible with our line of instruments. These include: Coriolis, magnetic, nozzle, open-channel, orifice, pitot/annubar, positive displacement, rotometers, thermal mass, turbine, venturi, and vortex. Our flow instruments also operate with many proprietary flowmeter types.

## **Applications Assistance**

KEP has a large number of applications engineers to assist you in selecting the most appropriate instrument for your application. Our application engineers can provide the detailed "know how" necessary to setup each instrument and to assist in the electrical interconnection between the flowmeter and the instrument.

## **Special Configurations**

In addition to the standard products listed in this catalog, KEP offers in house engineering capabilities to customize the products and enclosures to meet the special needs of customers. Please contact us with you requirements.

## **Selection Guides**

The pages which follow include two selection guides. The first is a preliminary selection guide to help you select several instruments that appear suitable for use with your flowmeter type and perform the intended instrument functions. The second selection guide contains a feature grid to help you make your final selection.

If you are unfamiliar with some aspect of the equipment selection or utilization, please review the tutorials that appear at the start of each section. These include answers to the most frequently asked questions we encounter while assisting customers.

## **Web Site**

Visit our web site ([www.kep.com](http://www.kep.com)) for the latest datasheets, user manuals, setup software, application notes and other vital information.



# Product vs. Flow Meter Compatibility Table

Flow Meter Type	Flow Indicators Rate & Totalizers				Flow Batch Controllers				Flow Computers			Level and Special Instruments				
	SQUIRT, SQUIRT-R BAT R/T, RAT & D/T	INT-69 / INT-69PM2	MINITROL, PW & S	KEPTROL R/T	SUPERCONTROL - 1 LE	MINIBATCHER	BATCHCONTROL II	MASSBATCH	SUPERCONTROL - 1	MASSTROL - II	LEVELTROL / DPFC	KEPTROL II	INTELLECT-F/C	FLOWTROL		
Coriolis	2	1	2	1	1,2	1	1	1,2		*				1	2	1
Differential Producers:	*		*, 3		*, 3			*, 3		*	*	*				
Venturi																
V-Cone																
Flow Nozzle																
Wedge																
Elbow																
Orifice																
Pitot / Annubar																
Magnetic	2	1	2	1	1, 2	1	1	1, 2	1	*	*	*		1	2	1
Positive Displacement	2	*	2	*	*	*	*	*	*	*	*	*		*	2	*
Propeller (turbo)	2	*	2	*	*	*	*	*	*	*	*	*		*	2	*
Roto Meter (Variable Area)					2, 4			2, 4		*	2	2, 4				
Target	*		*, 3		*, 3			*, 3		*	*	*, 3				
Turbine (paddle wheel & Insertion)	2	*	2	*	*	*	*	*	*	*	*	*		*	2	*
Thermal	*	1	*	1	*, 2	1	1	*, 2		*				1	*	1
Ultrasonic	2	1	2	1	1	1	1	1	1	*	*	*		1	2	1
Vortex	2	*	2	*	*	*	*	*	*	*	*	*		*	2	*
Open Channel Weirs & Flumes					2, 4			2, 4		2, 4	2, 4	2, 4				
ILVA / GilFlo											*					

## NOTES:

\* Recommended

1. Recommended for flow sensors equipped with pulse out converter
2. Recommended for flow sensors equipped with analog out converter
3. KEP unit must be equipped with optional Square Root Extraction feature
4. Multi point linearization option required

# Product vs. Feature Table

Features	Flow Indicators Rate & Totalizers								Flow Batch Controllers			Flow Computers		Level and Special Instruments		
	SQUIRT	BAT R/T, RAT & D/T	INTELLECT-69	MINITROL / DRT	ST-1 & ST-1LE	KEPTROL R/T	BATCHTROL II	MASSBATCH	ST-1 & ST-1LE	MINIBATCHER	SUPERCONTROL - II	MASSTROL / DPFC	LEVELTROL II	KEPTROL F/C	INTELLECT-69PM2	FLOWTROL
AC Powered			●	●	●	●	●	●	●	●	●	●	●	●	●	●
DC Powered		●	●	●	●	●	●	●	●	●	●	●	●	●	●	●
Loop Powered	●	●														
Battery Powered		●														
DC Power Output			●	●	●	●	●	●	●	●	●	●	●	●	●	●
LED Display			●	●		●	●		●				●	●	●	
LCD Display	●	●														
2 x 20 Char. Backlit LCD Display					●			●		●	●	●				
2 x 20 Char. VFD Display					●			●		●		●				
Multiple Language Capabilities										●						
Rate Display	4.5	4.5	4.5	4.5	6	6	6	6	6	4	6	6		6	4.5	6
Total Display	8	8	6	6	12	8	8	8	12	6	12	12	12	8		8
Accumulative Total (grand total)				6	12	8	8	8	12		12		12	8		8
Net Total Display (A-B, A+B)				●										●		
Net Rate Display (A-B, A+B)				DRT										●		
Two Pulse Inputs, Separate Scaling				●										●		
Pulse Inputs		●		●	●	●	●	●	●	●	●			●		●
Magnetic Pickup Inputs		●		●	●			●	●	●	●					
Quadrature Inputs				●	●			●								
Analog Inputs	●		●		ST1	●	●		●		●	●	●		●	
Square Root Extraction	●		●		ST1	●	●		●		●	●				
Multi Point Linearization		●			●	●	●	●	●		●	●	●			
Stacked DP Inputs											●	●				
Batching Capability					●		●	●	●	●			●			●
Remote Reset	●	●	●	●	●	●	●	●	●	●			●	●		●
Remote Start & Stop Inputs					●		●	●	●	●			●			●
Alarm Outputs		RAT	●	●	●	●	●	●	●	●	●	●	●	●	●	●
Analog Outputs		●	●	●	●	●	●	●	●	●	●	●	●	●	●	
Pulse Outputs	●	●			●	●	●	●	●		●	●	●	●		●
RS-232 Serial Communication			●	●	●	●	●	●	●	●	●	●	●	●	●	●
RS-422 Serial Communication			●	●		●	●		●				●			●
RS-485 Serial Communication				●	●				●	●						
Temperature Compensation								●	●		●	●	●			
Heat (BTU) Equations											●	●			●	
Steam Equations											●	●				
Volume Equations	●	●	●	●	●	●	●	●	●	●	●	●	●	●		●
Corrected Volume Equations									●	●		●	●	●		
Mass Equations									●	●		●	●	●		●
Gas Equations											●	●				
NEMA4 (water tight) Enclosure	●	●	●	●	●	●	●	●	●	●	●	●	●	●	●	●
NEMA7 (explosion proof) Enclosure	●	●	●	●	●	●	●	●	●	●	●	●	●	●	●	●
MPP-2400 Modem					●				●		●					
TWP Two Way Pager											●					

NOTE: Refer to datasheets for compatibilities of other models not listed

# Signal Conditioners and Converters Tutorial

Signal conditioners, signal converters, transmitters and amplifiers are devices which represent the majority of the basic instrumentation requirements for transducers. They are provided with flow, temperature, pressure, as well as many other transducer sensor types.

In some cases the signal conditioner/converter is provided by the sensor manufacturer so the user will have his desired output signal.

However, in other cases, there is a need for an external signal conditioner/converter to provide the desired output signal or to provide it at a more attractive price.

Signal conditioners and converters are ancillary devices intended to amplify, filter, condition, scale, and convert the low level "raw" signals produced by many transducers and convert it into the desired, industry standard high level signal before transmitting it across a potentially noisy environment. In some cases, a secondary function is providing signal isolation.

Generally, the output signals from the sensor may be in the form of either a pulse or analog current / voltage that is proportional to the span of the signal being measured. Open collector transistors are common as pulse output signals. The most common analog signal is a 4-20mA.

In many flowmeter types the frequency of the raw input signal carries the flow information. The frequency is related to flow rate. Each pulse or cycle is related to a small equivalent quantity of flow. The quantity represented by each pulse varies with each individual meter and must be scaled to obtain engineering units.

The input signal to a pulse signal conditioner may be a contact closure, a magnetic pickup, or a low level pulse. Some conditioner/converters scale the pulse signal such that each pulse represents a engineering quantity of flow (for example 1 pulse per gallon). Some converters convert the variable frequency signal into a current proportional to flow rate.

In nearly all cases the signal conditioner/converter is intended to be powered by a DC supply voltage normally available in most instruments with 24 VDC being the most common.

Enclosures are available for outdoor weatherproof and also hazardous locations.

Signal Conditioner/Converters are applied in most PLC and PC based control systems to adapt the raw process transducer signals into the standardized levels provides on I/O Cards.

Only the most common signal conditioner/converters applicable for flow metering are shown in the data sheets to follow.

## Typical Application:

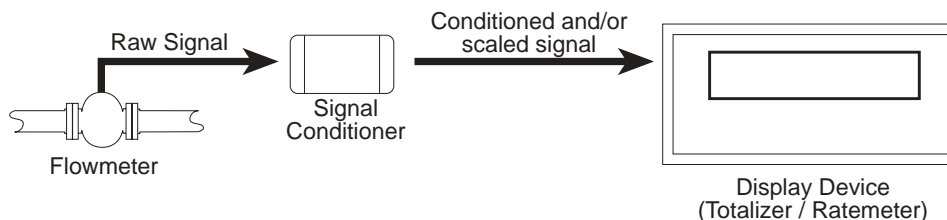

# SC-FI Series

## Frequency to Current Signal Conditioner

### Features:

- Magnetic Pickup or Contact Closure Input
- Optically Isolated Input
- 10 kHz Maximum Input Frequency
- Standard, 2-Wire, 4-20 mA Output
- Two Year Warranty
- Loop Powered
- Various Mounting Styles
- LED Indicator



### Description:

The SC-FI is a two wire frequency to analog converter that converts a pulse rate input into a 4-20 mA output signal proportional to frequency or rate.

The input pulse rate is amplified and filtered by the input signal conditioning circuitry. Two forms of input signal conditioning are provided, one for magnetic pickups or contact closure inputs and the other is an isolated pulse input (depending on order code).

The amplified frequency signal is then converted to an analog signal using a precision frequency to analog converter.

The output stage derives its power from the output current loop. The output stage converts the analog input signal into the desired output range. Multi-turn potentiometers provide for the necessary trimming of span and zero.

### Specifications:

#### Operating Temperature

32° F (0°C) to 158°F (70°C)

#### High Level Pulse Input

Type: Opto-Isolated  
Input Impedance: 3.3 kΩ  
Logic 1: 4-30 VDC  
Logic 0: 0-1 VDC  
Frequency Range: 0-10 kHz  
Fault Protection: Reverse Polarity Protection  
Over Voltage Protection  
Isolation Voltage: 500 V  
Fast Transient Immunity: 500 V  
Maximum Rise Time: No Limit  
Maximum Fall Time: No Limit

#### Magnetic Pickup Input

Differential Input  
Input Impedance: 10 kΩ  
Frequency Response: 0-3500 Hz  
Trigger Sensitivity: 30 mV p-p  
Over Voltage Protection: ± 30 VDC

#### Contact Closure Input

Sensor Compatibility- Requires an isolated, contact closure  
Maximum Contact Voltage- 5 V  
Maximum Contact Current- 0.12 mA  
Nominal Pullup Resistance - 47 Kohm to 5 Vdc  
Frequency Range - 0-100 Hz

### Frequency to Current Conversion

Range Selection: DIP Switch Selectable

Available Ranges:

#### Standard

150 Hz, 300 Hz, 600 Hz, 1200 Hz,  
2500 Hz, 5000 Hz, 10,000 Hz

Factory Default: 1000 Hz

#### Contact Closure Option

30 Hz, 60 Hz, 120 Hz, 240 Hz,  
480 Hz, 960 Hz, 1920 Hz

Factory Default: 100 Hz

### Analog Output

Accuracy: ± 0.1% Span (@ 20° C)  
Output Type: Two Wire, Loop Powered  
Range: 4-20 mA  
Compliance Voltage: 10 to 40 VDC  
Loop Burden: < 10 VDC  
Trim Controls: Zero & Span, non-interacting  
Span (20 mA) Trim Range: 50% to 100% of full scale  
Linearity: < ±0.1% Span  
Output Voltage Effect: < ± 0.002% Span/Volt  
Temperature Effect: < 200 PPM/C°  
Reverse Polarity Protected  
Noise Content: < 0.2% Span  
Response Time: 0.1 second (1 sec. jumper selectable)  
Overcurrent Limiting: 35 mA  
Output Loop Indicator: LED illuminates when output loop is powered by proper polarity and blinks proportionally to the input frequency.

### Mounting Styles

DIN Rail Mount: Plastic enclosure with a snap fastener for fitting to DIN 46 277 and DIN EN 50 022 assembly rails.

NEMA 4X: 4.92" x 4.92" NEMA 4X Enclosure for wall mounting.

Explosion Proof: Aluminum enclosure for:  
Class I, Division 1, Groups B, C & D  
Class II, Division I, Groups E, F & G.

Listing: CE Compliant

**Dimensions**

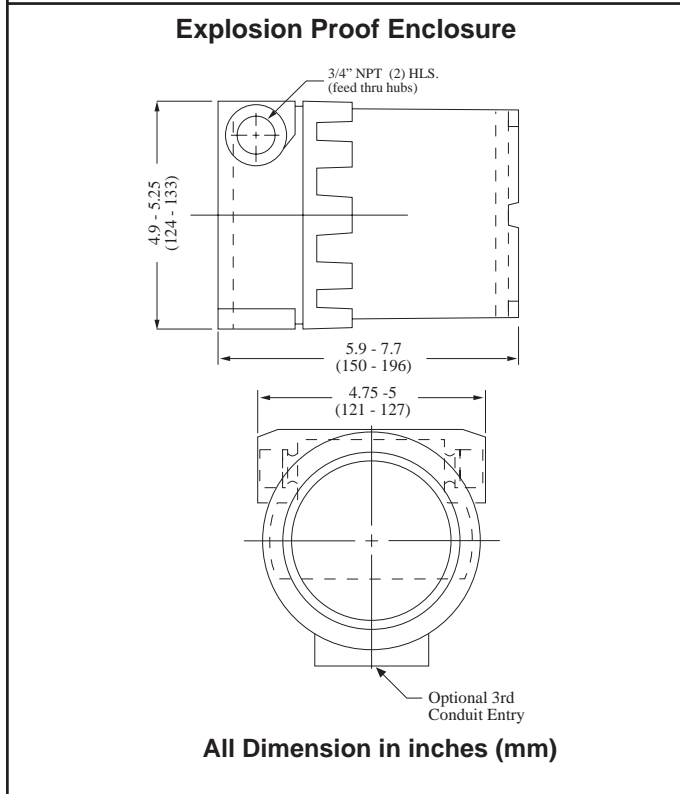
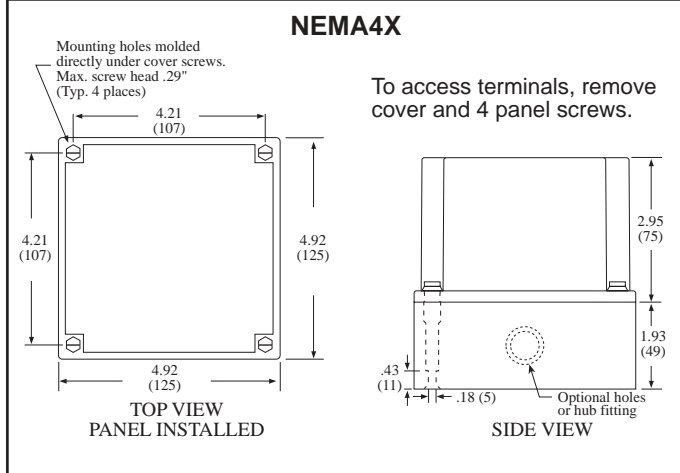
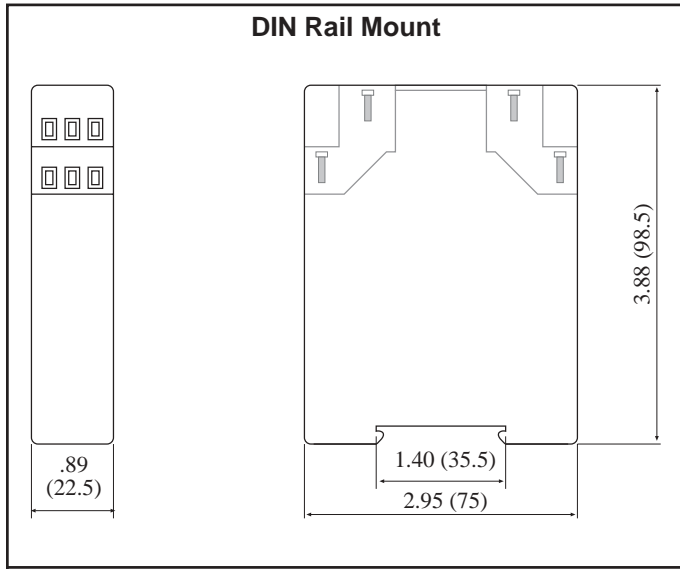

**Terminal Designations**

**Standard**

**Termination**

- 1• Magnetic pickup
- 2• Magnetic pickup
- 3• Shield (common)
- 4• Opto-isolator In +
- 5• Opto-isolator In -
- 6• Shield (common)
- 7• Output +
- 8• Output -
- 9• Do Not Use

**SCFI-X-L (low count speed)**

**Termination**

- 1• Do Not Use
- 2• Contact Input
- 3• Shield (common)
- 4• Opto-isolator In +
- 5• Opto-isolator In -
- 6• Shield (common)
- 7• Output +
- 8• Output -
- 9• Do Not Use

**Simplified Block Diagram**

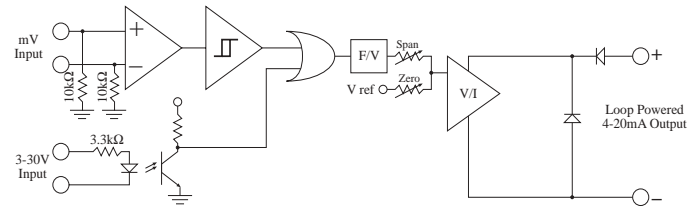

**Typical Application  
Magnetic Pickup Input**

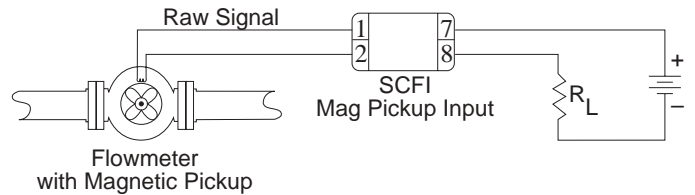

**Typical Application  
Contact Closure Input**

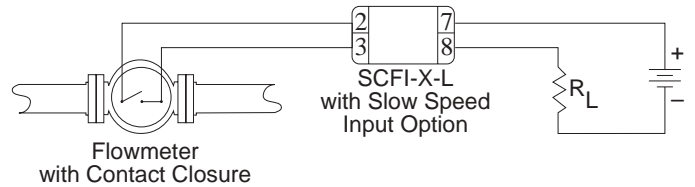

**Ordering Information**

Example	SC-FI	D	ET
<b>Series</b>	FI= Frequency to Current		
<b>Mounting:</b>	B= Nema 4X C= Explosion Proof D= DIN Rail		
<b>Options:</b>	ET= Extended Temp: -4° to 185°F (-20° to 85° C) L = Low Count Speed for Contact Closure Inputs T = Third 3/4" conduit entry for Explosion Proof Housing H2 = 0.875" Hole for NEMA4 mounting style HF2 = 0.5" Female NPT Hub fitting H3 = 1.125" Hole for NEMA4 mounting style HF3 = 0.75" Female NPT Hub fitting		

**Accessories:** (add to end of part number)  
DR-4= 4" DIN Rail



# SC-II SERIES

## Current to Current Loop Powered Isolator

### Features

- 4-20 mA Input (10-50 mA optional)
- 2-Wire, 4-20 mA Output (10-50 mA optional)
- Two Year Warranty
- Loop Powered
- Input & Output LED Indicators
- Various Mounting Styles



### Description:

The SC-II loop powered isolator is a signal conditioner whose function is to provide a retransmitted, galvanically isolated 4-20 mA output signal in response to isolated 4-20 analog input.

The loop powered isolator may be applied in a similar manner as a conventional two wire transmitter.

The SC-II appears to the input loop as a series shunt resistor. A small sense resistor is used to measure the input current. The input loop derives its power from the input current loop.

This input current signal is then scaled and converted to a 0 to 10,000 Hz frequency signal by a Current to Frequency Converter. This frequency signal is then transmitted across an optoisolator to the output stage.

The output stage derives its power from the output current loop. The output stage converts the 0-10000 Hz frequency signal into a current flowing in the output loop equal to that flowing in the input current loop.

The 10-50 mA range options are provided to enable the unit to perform range conversions as well as signal isolation.

### Specifications:

#### Analog Input

Available Ranges: 4-20 mA (10-50 mA optional)

Input Type: Two Wire, Loop Powered

Equivalent Input Impedance: 525  $\Omega$  on 4-20 mA range  
210  $\Omega$  on 10-50 mA range

Operational Range: 3.5-33 mA

Over Current Protection: 2.5 times rated span

Reverse Polarity Protection

Isolation Voltage: 500 V

Input Loop Indicator: LED illuminates when loop is powered by proper polarity

### Analog Output

Accuracy:  $\pm 0.10\%$  Span

Output Type: Two Wire, Loop Powered

Range: 4-20 mA (10 - 50 mA optional)

Compliance Voltage: 10 to 40 VDC

Loop Burden: < 10 VDC

Trim Controls: Zero & Span

Linearity: <  $\pm 0.10\%$  Span

Output Voltage Effect: <  $\pm 0.002\%$  Span/Volt

Temperature Effect: < 200 PPM/C $^{\circ}$

Reverse Polarity Protected

Noise Content: < 0.2% Span

Overcurrent Limiting: 35 mA

Output Loop Indicator: LED illuminates when output loop is powered by proper polarity

### Mounting Styles

DIN Rail Mount: Plastic enclosure with a snap fastener for fitting to DIN 46 277 and DIN EN 50 022 assembly rails.

NEMA 4: 4.92" x 4.92" NEMA 4 Enclosure for wall mounting.

Explosion Proof: Aluminum enclosure for:  
Class I, Division 1, Groups B, C & D  
Class II, Division I, Groups E, F & G.

**Listing:** CE Compliant

### Dimensions

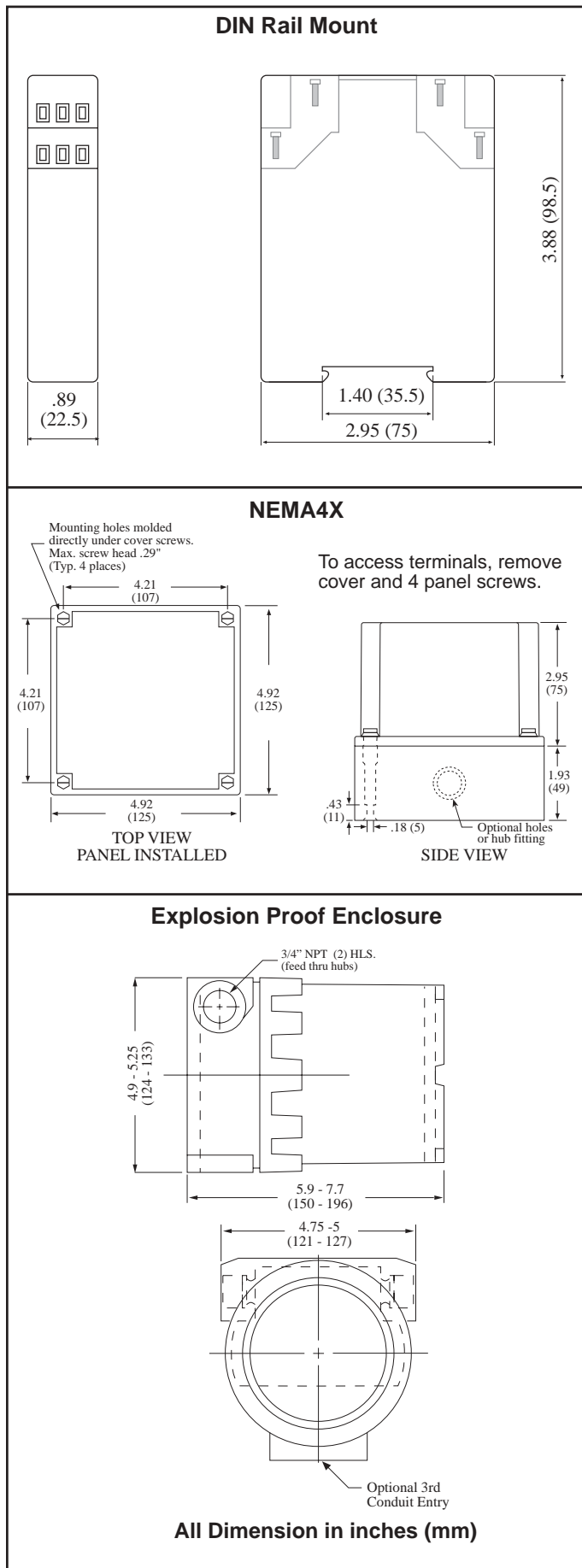

### Simplified Block Diagram

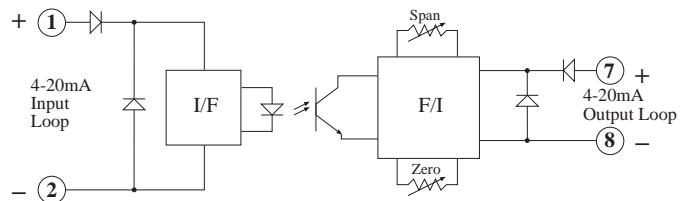

### Typical Wiring Hookup

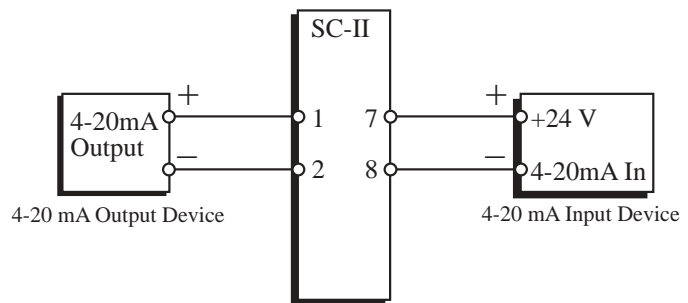

### Ordering Information

<b>Example</b>	<b>SC-II</b>	<b>D</b>	<b>ET</b>
<b>Series</b>	II = Current to Current		
<b>Mounting:</b>	B = Nema 4X C = Explosion Proof D = DIN Rail		
<b>Options:</b>	ET = Extended Temp: -4° to 185°F (-20° to 85° C) T = Third 3/4" conduit entry for Explosion Proof Housing H2 = 0.875" Hole for NEMA4 mounting style HF2 = 0.5" Female NPT Hub fitting H3 = 1.125" Hole for NEMA4 mounting style HF3 = 0.75" Female NPT Hub fitting		
<b>Accessories:</b> (add to end of part number)	DR-4 = 4" DIN Rail		

# SC-IF SERIES

## Current to Frequency Loop Powered Isolator

### Features

- 4-20 mA Input (10-50 mA optional)
- 0 to 10 kHz Pulse Output
- Two Year Warranty
- Loop Powered
- Input & Output LED Indicators
- Various Mounting Styles



### Description:

The SC-IF loop powered signal conditioner whose function is to provide a 0 - 10kHz frequency output signal in response to a 4-20mA analog input.

The SC-IF appears to the input loop as a series shunt resistor. A small sense resistor is used to measure the input current. The input loop derives it's power from the input current loop.

This input current signal is then scaled and converted to a 0 to 10,000 Hz frequency signal by a Current to Frequency Converter. This frequency signal is then transmitted across an optoisolator to the output stage.

The 10-50 mA range option is provided to enable the unit to perform range conversions as well as signal isolation.

### Specifications:

#### Analog Input

Available Ranges: 4-20 mA (10-50 mA optional)

Input Type: Two Wire, Loop Powered

Equivalent Input Impedance: 525  $\Omega$  on 4-20 mA range  
210  $\Omega$  on 10-50 mA range

Operational Range: 3.5-33 mA

Over Current Protection: 2.5 times rated span

Reverse Polarity Protection

Isolation Voltage: 500 V

Input Loop Indicator: LED illuminates when loop is powered by proper polarity

### Pulse Output Option

Output Type: Open Collector Transistor

Low Cutoff: 1% of full scale

Range: 0 to 10,000 Hz

Duty Cycle: 50/50 Duty Cycle (nominal)

Maximum Off Voltage: 30 VDC

Minimum On Current: 10 mA

Maximum On Voltage: 1 VDC

Temperature Effect: Less than 200 ppm/degree C

Reverse Polarity Protection

### Mounting Styles

DIN Rail Mount: Plastic enclosure with a snap fastener for fitting to DIN 46 277 and DIN EN 50 022 assembly rails.

NEMA 4: 4.92" x 4.92" NEMA 4 Enclosure for wall mounting.

Explosion Proof: Aluminum enclosure for:  
Class I, Division 1, Groups B, C & D  
Class II, Division I, Groups E, F & G.

**Listing:** CE Compliant

**Dimensions**

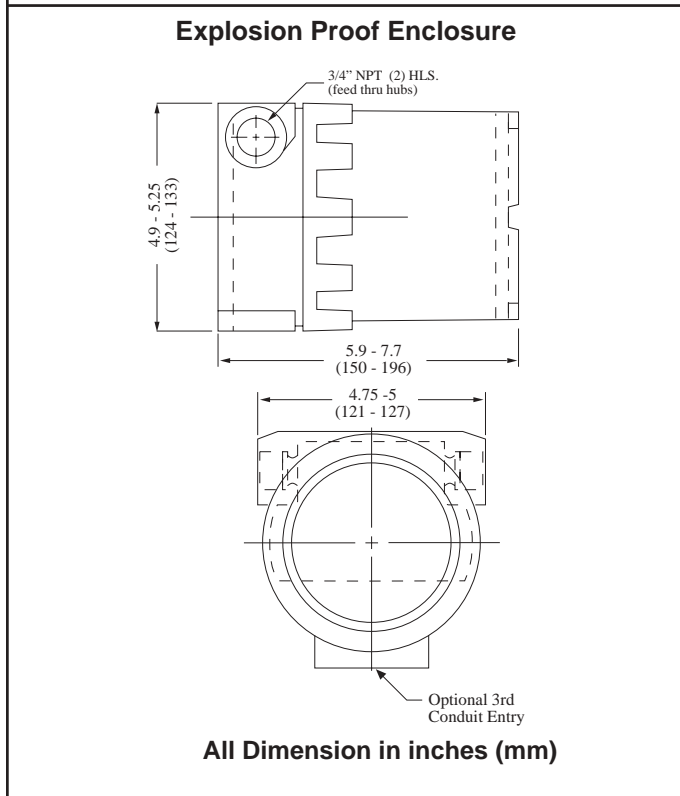
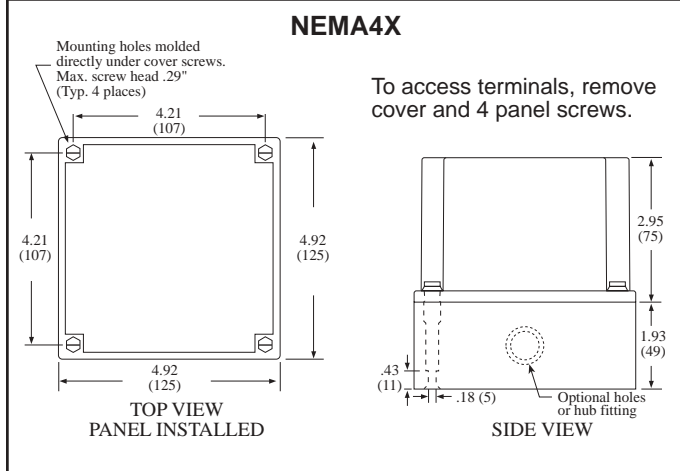
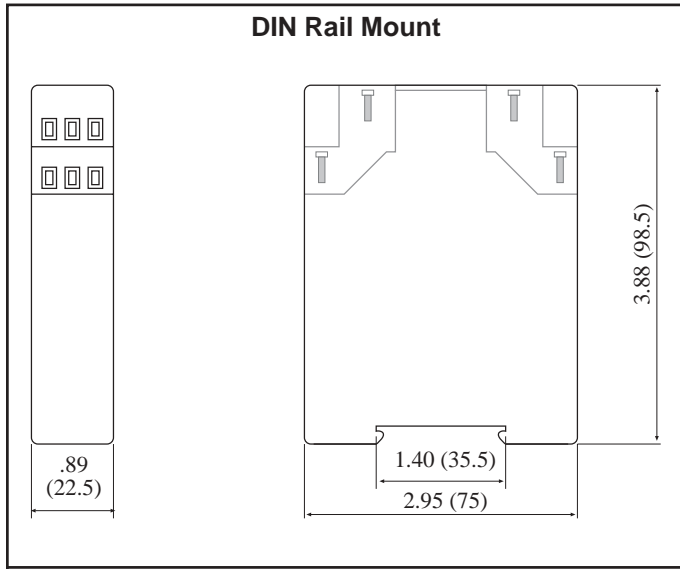

**Simplified Block Diagram**

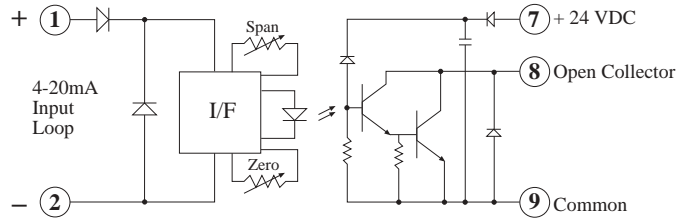

**Typical Wiring Hookup**

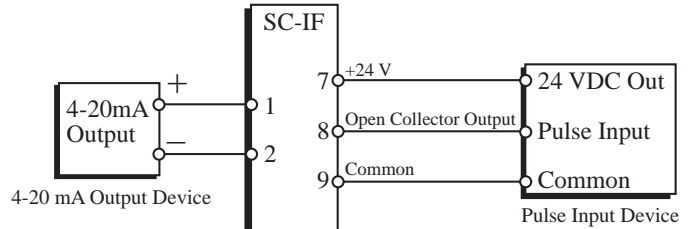

**Ordering Information**

**Example** SC-IF D ET

**Series** SC-IF

IF = Current to Frequency

**Mounting:**

- B = Nema 4X
- C = Explosion Proof
- D = DIN Rail

**Options:**

- ET = Extended Temp: -4° to 185°F (-20° to 85° C)
- T = Third 3/4" conduit entry for Explosion Proof Housing
- H2 = 0.875" Hole for NEMA4 mounting style
- HF2 = 0.5" Female NPT Hub fitting
- H3 = 1.125" Hole for NEMA4 mounting style
- HF3 = 0.75" Female NPT Hub fitting

**Accessories:** (add to end of part number)

- DR-4 = 4" DIN Rail

# SC-FF Series

## Frequency to Frequency Pulse Isolator and Scaler

### Features:

- Pulse Scaler with Isolation
- Pulse, Contact Closure or Magnetic Pickup Inputs
- Two Year Warranty
- Various Mounting Styles
- Output LED Indicator



### Description:

The model SC-FF is a signal conditioner which permits the user to condition and scale the input pulses from a pulse producing sensor into a high level output where each pulse represents an engineering unit of measure.

Several pulse input types are supported including magnetic pickup, contact closure, and an isolated pulse input.

The pulse scaling permits a user to apply a scaling multiplier with a value of .0001 to .9999 with additional multipliers of 1, .1, .01, .001 and .0001. Pulse scaling is accomplished by rotary encoded and dip switch selections.

The pulse output is available in isolated, non-isolated and relay versions. User selections include output pulse duration and internal pullup resistors. The user may select his pulse output configuration by means of a dip switch.

The unit is powered to 8 - 35 VDC. Reverse polarity protection is provided. Power and Pulse input/output indicators are provided.

The unit is available in enclosures intended for either DIN rail, NEMA4X or Explosion Proof.

### Specifications:

#### Pulse Input:

##### Isolated Pulse:

- Logic 1 (high): 3 - 30 VDC
- Logic 0 (low): 0-0.4 VDC
- Input Frequency Range: 0-10000 Hz
- Input Impedance: 3.3 kΩ
- Reverse Polarity Protection
- Isolation Voltage: 500 V

##### Contact Closure:

- Switch Debounce: 40 CPS maximum count rate
- 10000 ohm internal pullup to 5 VDC

##### Magnetic Pickup:

- Sensitivity: 30 mV p-p
- Bandwidth: 0-3500 Hz
- Over Voltage Protection to 30 VDC
- 10 Kohm input resistance

### Pulse Output:

Pulse Duration: 50 uSec, 500 uSec 50 mSec (Switch selectable)

#### Open Collector Pulse:

- Maximum Voltage: 48 VDC
- Maximum Current: 100 mA @ .7V max
- Max. Output Speed: 10 kHz
- Reverse Polarity Protection
- Overcurrent Protection
- Jumper selectable for 5 V and 24 V pulse output

#### Isolated Pulse:

- Maximum Voltage: 30 VDC
- Maximum Current: 10 mA
- Max. Output Speed: 1 kHz
- Isolation Voltage: 500 VDC
- Reverse Polarity Protected

#### Output Relay (optional):

- Contact Rating: 0.5 amps 240 VAC
- Output Form: Form A (SPST)
- Max. Output Speed: 10 KHz

### Power Input:

- Input Voltage Range: 8.5 to 35 VDC
- Supply Current: 25 mA (nominal)
- Reverse Polarity Protection
- Transient Protection

### Pulse Scaling:

- Scaler: 0.0001 to .9999
- Multiplier: X1, X0.1, X0.01, X0.001, X0.0001

### Mounting Styles

- DIN Rail Mount: Plastic enclosure with a snap fastener for fitting to DIN 46 277 and DIN EN 50 022 assembly rails.
- NEMA 4X: 4.92" x 4.92" NEMA 4X Enclosure for wall mounting.
- Explosion Proof: Aluminum enclosure for:  
Class I, Division 1, Groups B, C & D  
Class II, Division I, Groups E, F & G.

**Listing:** CE Compliant

**Dimensions**

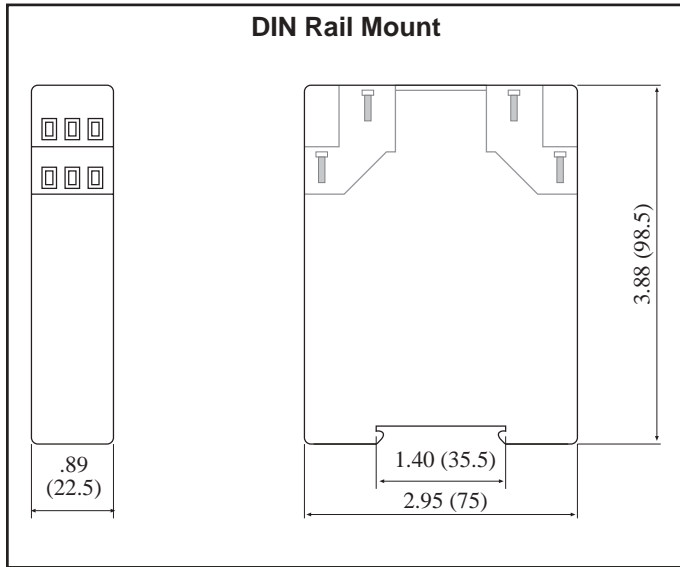

**Simplified Block Diagram**

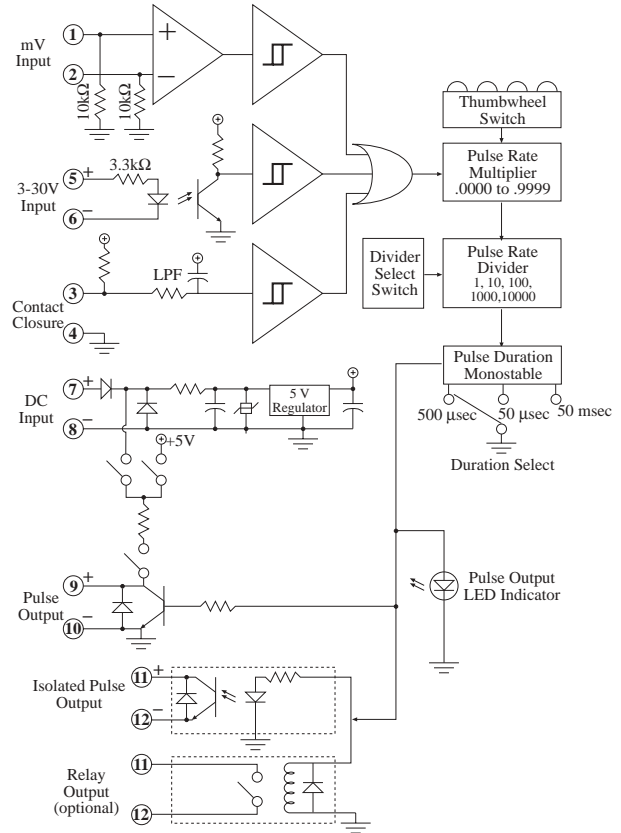

**Wiring:**

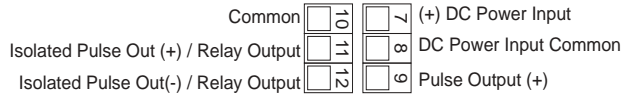
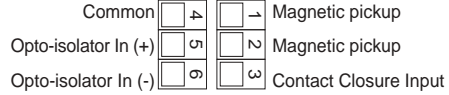

**Typical Application:**

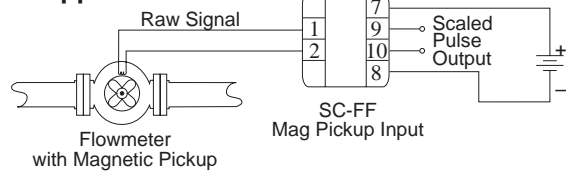

**Ordering Information**

<b>Example</b>	<b>SC-FF</b>	<b>1</b>	<b>B</b>	<b>ET</b>
<b>Series</b>	FF= Frequency to Frequency			
<b>Output Type</b>	1 = Open Collector & Isolated Pulse (STD) 2 = Open Collector & Relay Output			
<b>Mounting:</b>	B= Nema 4X C= Explosion Proof D= DIN Rail			
<b>Options:</b>	ET= Extended Temp: -4° to 185°F (-20° to 85° C) T = Third 3/4" conduit entry for Explosion Proof Housing H2 = 0.875" Hole for NEMA4 mounting style HF2 = 0.5" Female NPT Hub fitting H3 = 1.125" Hole for NEMA4 mounting style HF3 = 0.75" Female NPT Hub fitting			

**Accessories:** (add to end of part number)  
DR-4= 4" DIN Rail

# AMP-1-N

Preamplifier & Signal Conditioners  
For NAMUR Sensors

## Features

- NAMUR Compatible Sensitivity.
- 100 mA Current Sinking Output.
- 11 to 26 VDC Power Supply Range.
- Easy Mount Metal Housing.
- Screw Terminal Hookup.



## Description

The KEF AMP-1-N powers and conditions the low level signals from NAMUR pickups, sensing gear teeth movement or flow, and provides a high level pulse output suitable to drive any KEF ratemeter, counter or controller.

## Application

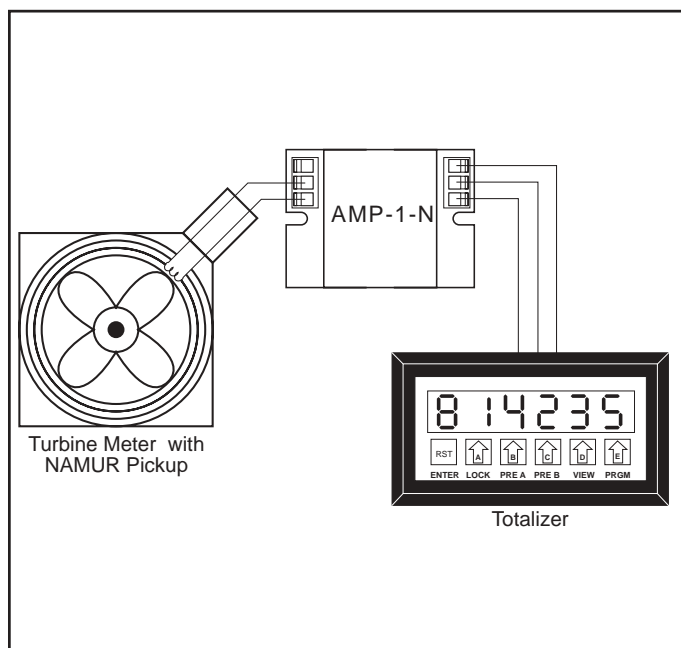

## Specifications

### Environmental

- Operating temperature: 32° to 140° F (0° to 60° C)  
Storage temperature: -40° to +85° C  
Humidity: 0 - 95% non-condensing

### Power Input

- Power requirement: 11-26VDC; 30mA maximum  
Sensor Supply: 8VDC  $\pm$  1 VDC

### Input Characteristics

- Input impedance: 1000 ohm nominal  
Input frequency : 0 - 10kHz  
Input current: High: > 3mA  
Low: < 1 mA

### Output Characteristics

- Output Type: Open collector with internal 2700 ohm pull-up resistor to supply voltage.  
Max. sink current: 100mA sink to 1V or less

### Approvals:

- CE approved; Light Industrial  
Fast transient: 500V (capacitive clamp)  
EMI: No effects at 3V/m  
ESD: 8kV (case grounded)

# Process, Level, Temperature Monitors Tutorial

**What is a Process Indicator?** This is a general purpose instrument that is intended to condition the electrical signal generated by a process sensor and scale the resulting information into a display in the units of measure desired by the end user. Additional, functionality such as alarms, analog output, and serial communications may also be provided. See the figure below for a typical system configuration.

**What capabilities should I look for to assure compatibility with my type of sensor?** Indicators are available to work with most process sensor types and most common electrical signals produced by these sensors. Some are termed "universal" and operate with many sensor types. Begin by selecting an instrument(s) that will work with the signal provided by the type of sensor you are considering. In some cases an amplifier or signal conditioner may be necessary. Next, decide on whether linearization or other forms of compensation will be required within the Indicator and on how the calibration will be represented within the instrument. Also determine if the Process Indicator can provide the power required for the sensor (if needed).

**What are some basic areas of concern?** Most customers begin selecting an indicator by looking for an instrument that will display the type of information that they prefer. It must work with the available power and must be available in a package that can be mounted in the desired location.

**What is an analog output and why is it used?** Process information is usually sent from one system to another as a 4-20mA. Some instruments permit the user to select what item of information is to be sent on the analog output. The corresponding span is user programmable. Additional features may include programmable damping.

**What is an alarm output and why is it used?** Relays are often used as controls to activate alarms. An alarm will usually include a provision for setting the alarm point. Additional features may include a programmable delay before the alarm will activate, programmable alarm duration, and/or a programmable alarm hysteresis.

**What are remote inputs and how are they used?** Often there is a need to connect a remote switch near the operator for such purposes as remote alarm reset, or remote print. Some process indicators offer a variety of capabilities as remote inputs.

**What is serial communications and why is it used?** Serial communications is used to transmit information between two computers, or between a computer and a printer. There are several commonly used standard hardware interfaces. These include RS-232 RS-422 and RS-485. There are also a variety of communication protocols, or message formats, which are used. Some of these protocols are unique to an equipment manufacturer while others are industry standards. See also "Communication Solutions" section.

**What are other areas of concern?** Many areas where process indicators are installed are out of doors or are in hazardous areas. Special purpose enclosures are available for many instruments subject to these harsh conditions.

## Typical Applications

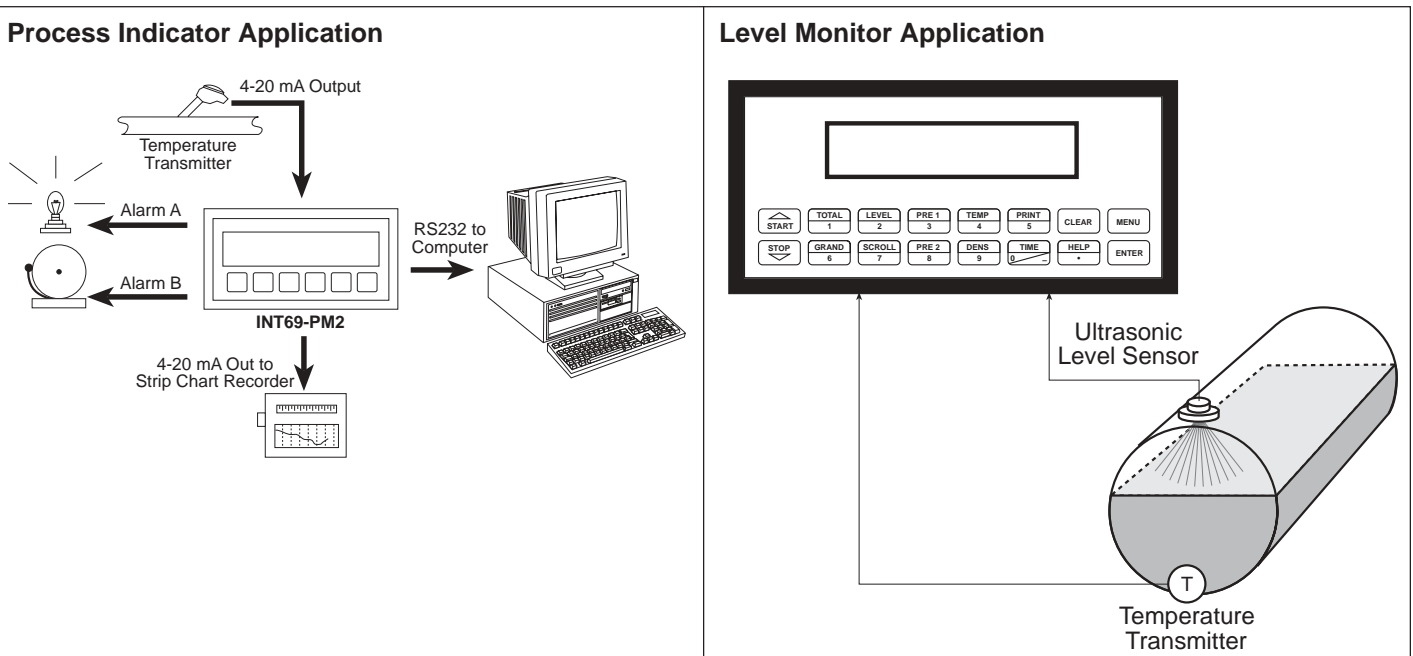



# 531 Series

## Temperature Display for Pt100 and Ni100 RTD's

### Features

- Compact and Low-Cost Temperature Display
- Temperature Display in °C or °F
- MIN/MAX Value Retention
- EEPROM Data Backup on Power Failure
- Galvanic Isolation with Reverse Polarity Protection
- Screw Terminal Connectors: pitch 5 mm
- Display Hold Input



- Two Button Programming
- 5 Measurements/second

### Specifications:

Supply voltage: 10-30 V DC, galvanically isolated with reverse polarity protection  
 Current draw: max. 40 mA  
 Display: 5-digit display, red LED's; height 8 mm  
 Measuring rate: 5 measurements/second  
 Display refresh: 1-2 times per second  
 Data backup: EEPROM  
 Housing: housing for control panel 48 x 24 mm acc. to DIN 43 700; RAL 7021, dark grey  
 Ambient temp.: -20 to +65 °C  
 EMC: according to EC EMC directive 89/36/EEC  
 Interference emissions: EN 50081-2/EN 55 011 Class B  
 Interference resistance: EN 6100-6-2  
 Protection: NEMA4 / IP65 (front)  
 Weight: app. 50 g  
 Circuit type: 2-wire, 3-wire and 4-wire connection technique, programmable  
 Input: Pt100 or Ni100 RTD with sensor breakage monitoring

Control inputs: High: 4-30 V DC, Low: 0-2 V DC  
 Supply current: 1 mA  
 Supply line: 2-wire: max 20 Ω, programmable 3-wire, 4-wire: max 20 Ω, no balancing required  
 Temp. ranges: Pt100 acc. to DIN IEC 751:  
 -199.9 °C to +850.0 °C  
 -327.8 °F to +1562.0 °F  
 Ni100 acc. to DIN 43760:  
 -60.0 °C to +250.0 °C  
 -76.0 °F ... +482.0 °F  
 Resolution: 0.1°C (0.1°F) or 1°C (1°F)  
 Linearity error: Pt100 < 0.1 % for entire measuring range at an ambient temperature of 20 °C  
 Ni100 < 0.2 % for entire measuring range at an ambient temperature of 20 °C  
 Temp. drift: 0.1 K/KAmbient

### Order #:

**531 = Temperature Display with RTD Input**

### Accessories:

**E200 - Outdoor Enclosure (see Accessories section)**

### Wiring:

#### Power Supply

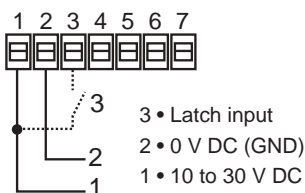

#### 2-Wire RTD

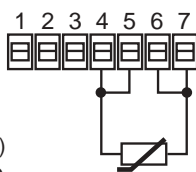

#### 3-Wire RTD

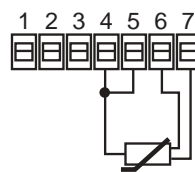

#### 4-Wire RTD

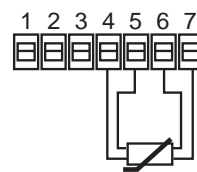

Panel Cutout: 0.876" x 1.78" (22.3 x 45.2mm)  
 or 0.99" x 1.97" (25 x 50mm) with adaptor provided

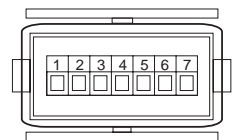
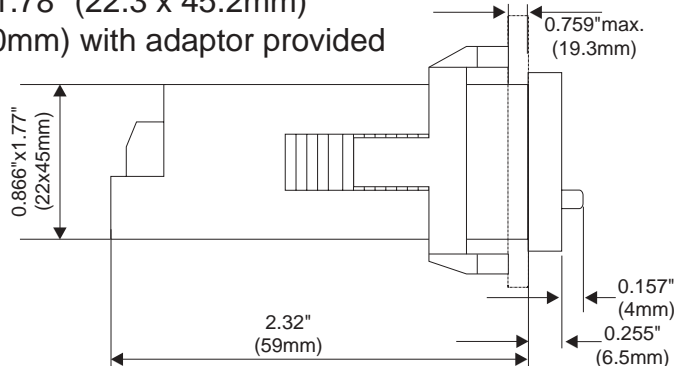
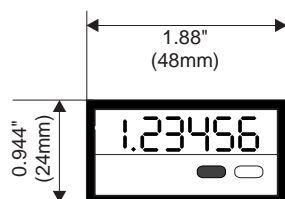

# 532 Series

## Temperature Display for J, K and N Thermocouples

### Features

- Compact and Low-Cost Temperature Display
- Temperature Display in °C or °F
- MIN/MAX Value Retention
- EEPROM Data Backup on Power Failure
- Galvanic Isolation with Reverse Polarity Protection
- Screw Terminal Connectors: pitch 5 mm
- Display Hold Input
- 5 Measurements/second



- J, K, N Thermocouples with External or Internal Cold Junction Compensation
- Two Button Programming

### Specifications:

Supply voltage: 10-30 V DC, galvanically isolated with reverse polarity protection  
 Current draw: max. 40 mA  
 Display: 5-digit display, red 7-segment LED's; height 8 mm  
 Measuring rate: 5 measurements/second  
 Display refresh: 1-2 times per second  
 Data backup: EEPROM  
 Housing: housing for control panel 48 x 24 mm acc. to DIN 43 700; RAL 7021, dark grey  
 Ambient temp.: -20 to +65 °C  
 EMC: according to EC EMC directive 89/36/EEC  
 Interference emissions: EN 50081-2/EN 55 011 Class B  
 Interference resistance: EN 6100-6-2  
 Protection: NEMA4 / IP65 (front)  
 Weight: app. 50 g  
 Input: Thermocouple Sensor  
 J (Fe-CuNi)  
 K (Ni-CrNi)  
 N (NiCrSi-NiSi)  
 with sensor breakage monitoring  
 Control inputs: High: 4-30 V DC, Low: 0-2 V DC  
 Supply current: 1 mA  
 Supply line: 2-wire: max 20 Ω, programmable 3-wire, 4-wire: max 20 Ω, no balancing required

Temp. ranges: according to DIN IEC 584  
 J (Fe-CuNi) -210.0 °C to +1200.0 °C  
 -346.0°F ... +2192.0 °F  
 K (Ni-CrNi) -200.0 °C ... +1372.0 °C  
 -328.0 °F ... +2501.6 °F  
 N (NiCrSi-NiSi) -200.0 °C ... +1300.0 °C  
 -328.0 °F ... +2370.0 °F  
 Resolution: 0.1°C (0.1°F) or 1°C (1°F)  
 Linearity error: < 0.4 % for entire measuring range at an ambient temperature of 20 °C  
 Cold junction error: ±1.0 °C typ. ±3.0 °C  
 Temp. drift: 0.1 K/Kambient

### Wiring:

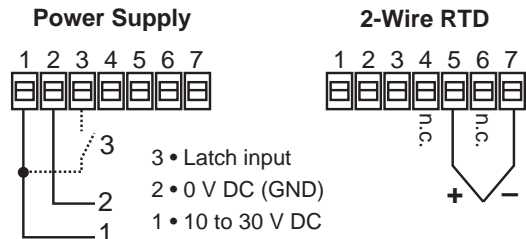

### Order #:

**532 = Temperature Display with thermocouple Input**  
**Accessories:**  
**E200 - Outdoor Enclosure (see Accessories section)**

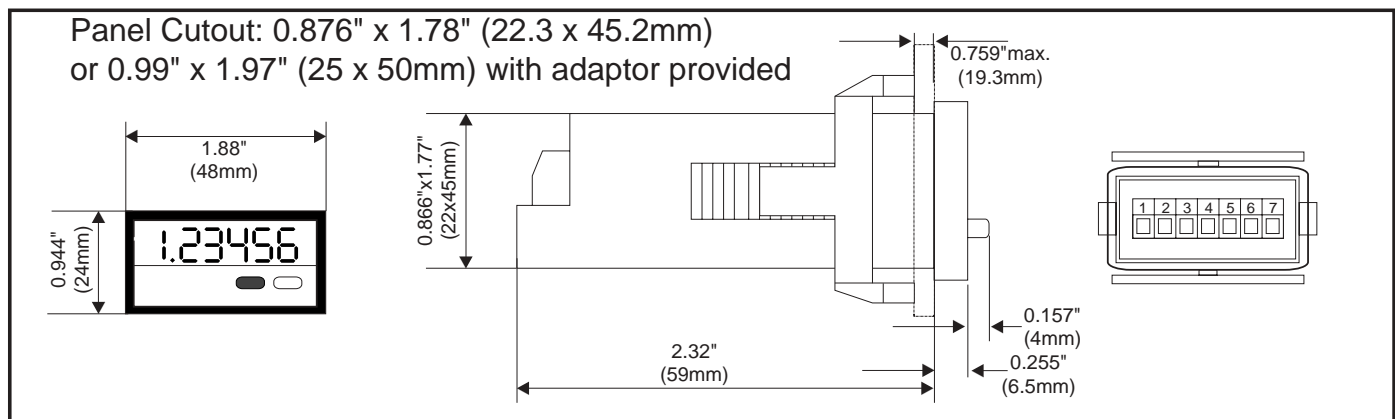

# TP-550 Series

## Temperature/Process Monitor With or Without Alarms

### Features

- Very bright LED display, height 14mm
- DIN housing, 96 x 48 mm
- Programmable operating curve for standard signals, thermocouples, resistance thermometers, etc.
- Programmable operating curve, even non-linear, allowing the use of economical sensors
- Two relay outputs with two preset limit values

### Additional features:

- DIN housing 96 x 48 mm
- Character height: 14 mm
- Resolution 14 bits
- Simple menu-driven programming, and operation with 4 keys
- Electrical connections by means of plug-in screw terminals
- Voltage supply: 10-30 VDC or 90-260 VAC
- IP 65/NEMA4 (front)
- Auxiliary power supply output for transducer or sensor
  - 10..30 VDC: 10 VDC  $\pm$  2%, 30 mA
  - 90..260 VAC: 24 VDC  $\pm$  15%, 50 mA and 10 VDC  $\pm$  2%, 30 mA
- Hum eliminator (50/60 Hz user selectable)
- Serial interface allows reading of the measured values and set-up programming.

### Dimensions

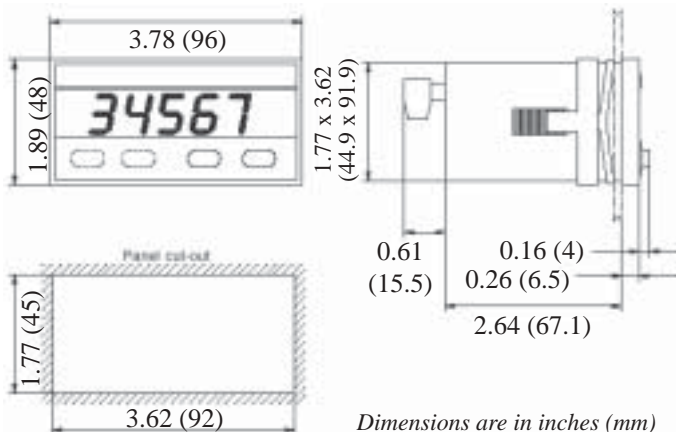

Flow Instruments  
PROCESS & LEVEL MONITORS

### TP554 Specifications:

Process controller for thermocouples, resistance thermometers and sensors with mV range; two preset limit values

- Display range: -19.999..99.999
- Input ranges:
  - 0..400  $\Omega$ , 0..4000  $\Omega$
  - 0..100 mV, -100..+100 mV

### Thermocouples

- Integrated operating curves for thermocouples (types B, C, D, E, G, J, K, L, N, R, S, T, U)
- Programmable input operating curve with up to 24 reference points
- 2 programmable limit values (TP551; unit without presets, has only 2 buttons)
- Outputs: Two (2) SPDT relays (250 VAC / 3A)
- Programmable hysteresis (on, off, on/off)
- SET key to reset the outputs
- Inputs: thermocouple, millivolt, resistance thermometer with measurement on 2, 3 or 4 wires, RESET to reset the outputs, KEY terminal to lock the front keys.

### Order Code

Example: TP554.010 0 00

Series:

TP551.012 = No Presets/Relays  
 TP554.010 = 2 Presets/Relays

Operating Voltage:

0 = 90 to 260 VAC  
 3 = 10 to 30 VDC

Options:

00 = without interface  
 05 = RS232  
 06 = RS422  
 07 = RS485

## Electrical Connections

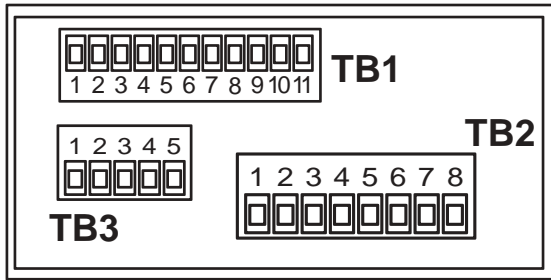

### TB1

- 1 Measuring input 1 (Sense)
- 2 Measuring input 2 (- Ref)
- 3 Sensor (+Ref)
- 4 Current output for 0 .. 4000 Ω (+ Sense)
- 5 Current output for 0 .. 400 Ω (+ Sense)
- 6 Keys locking
- 7 Reference ground Reset / Key
- 8 Reset
- 9 GND for DC Output (Pins 10 & 11)
- 10 +10 VDC Out (30 mA)
- 11 +24 VDC Out (50 mA) (AC units only)

### TB2

- 1 Relay 2 Com. (Opto-Emitter)
- 2 Relay 2 N.O.
- 3 Relay 2 N.C. (Opto-Collector)
- 4 Relay 1 Com. (Opto-Emitter)
- 5 Relay 2 N.O.
- 6 Relay 2 N.C. (Opto-Collector)
- 7 A.C. In (10-30 VDC)
- 8 A.C. In (Ground; 0 VDC)

### TB3

	RS232	RS485	RS422
1	GND	-	-
2	RxD	DO+/RI+	RI+
3	TxD	DO-/RI-	RI-
4	-	-	DO+
5	-	-	DO-

## Resistance measurements 0 .. 400/4000 Ω or Pt 100/1000

**2 wire measurement** (measuring resistance 0 .. 400/4000 Ω)

**NOTE:** Not recommended for long runs.

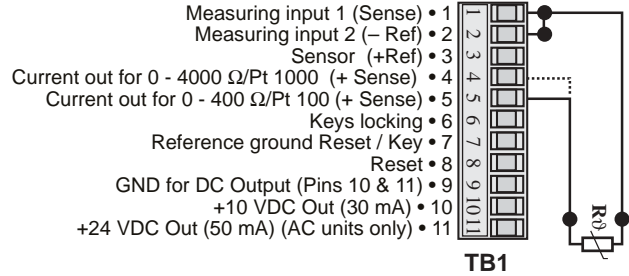

**3 wire measurement** (measuring resistance 0 .. 400/4000 Ω)

**NOTE:** Jumper 1 & 2 at meter, wires 3 & 4 must go to sensor

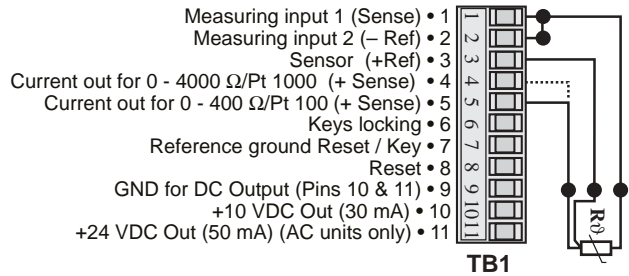

**4 wire measurement** (measuring resistance 0 .. 400/4000 Ω)

**NOTE:** All 4 wires must go to sensor

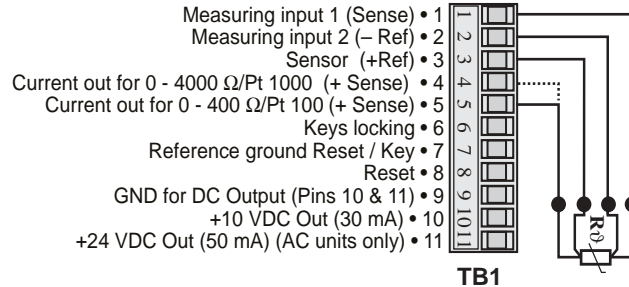

## Thermocouples

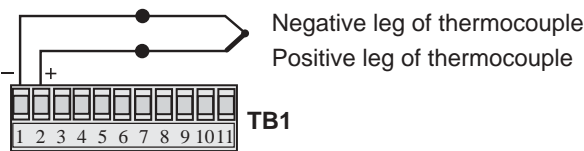

**NOTE:** For accurate readings, use only leads of same type thermocouple wire without junctions to dissimilar metals.

## Voltage measurement (0 to 100mV or -100 to +100mV)

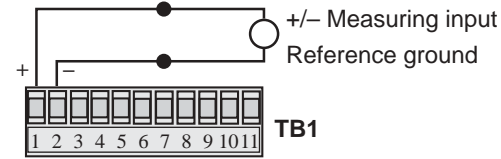

# Intellect-69PM2

## Process Monitor with Analog Inputs

### Features

- Analog Input 0-20 mA, 4-20 mA  
0-5V, 0-10V or 1-5V
- Display Rate, Pressure, Level, Temperature,  
Watts, etc., Peak & Valley
- Calibration, High and Low Values (-9999 to  
49999) Fully Programmable Through Keypad
- NEMA 4X / IP65 Front
- +24V Output for Peripherals
- 16 Bit A/D Resolution
- 2 Form C SPDT Relays (optional)
- 2 Levels of Operator Password Lockout

### Application:

Any process monitoring application where two set points and scaling are needed.

### Description:

Featuring 4<sup>1/2</sup> digits of bright, 7-segment LED displays, the Intellect-69PM2 is a process monitor which accepts analog signal inputs. The unit can be field programmed to accept 0-20mA, 4-20mA, 0-5V, 0-10V or 1-5V signals. Two assignable set points are standard for high/low alarm outputs. The high and low scaling settings (-9999 to 49999) are programmable from the front panel. By pressing the "view" button, the unit will display: process reading, peak or valley. Press the lock button once to freeze the display, press it again to resume normal operation. Press the lock button 4 times quickly to enter lock code for panel lockout. RS-232, RS-422 and 4-20mA analog out are available options for interfacing to a host computer or strip chart recorder.

### Specifications:

#### Display:

4<sup>1/2</sup> digit, .55" high, 7 segment, red orange, LED.

**Input Power:** 110, 220 VAC  $\pm$  15% or 12 to 24VDC.

Current: 300 max. mA DC or 10.0 VA (10W) at rated AC voltage.

#### Output Power:

(AC powered units only) + 24VDC @ 50mA regulated  $\pm$ 5%. (100 mA available on request)

#### Temperature:

Operating: +32°F (0°C) to +130°F (+54°C).

Storage: -40°F (-40°C) to +200°F (93°C).

**Memory:** EEPROM stores data for ten years if power is lost.



### Reset:

Front Panel: resets displayed value and control outputs.

### Control Outputs:

Standard: Open collector sinks 250mA from 30VDC when active.

Optional: 2 each Form C SPDT 5 Amp @ 120/240 VAC or 28 VDC.

**Input:** Linear 0-20mA, 4-20mA, 0-5V, 0-10V or 1-5V selectable from the front panel.

**Calibration:** The unit does all of the calibrations internally. There are no potentiometers to adjust and the unit never needs to be removed from the case or panel.

**Set Points:** Two control set points are provided. The unit comes standard with two open collector control outputs. Two 5 Amp, Form C relays are optional. The outputs have a programmable alarm range from -9999 to 49999 with hysteresis.

**Process Display:** Updates 4 times per second, Accurate to 4.5 digits.

**Programming:** Decimal points, Scaling from -9999 to 49999, set points, input type and security lock code are all programmable from the front panel.

**Housing:** Standard 1/8 DIN, high impact ABS plastic case (NEMA 4X/IP65 front panel).

**Shipping Weight:** 2 lbs.

**Overvoltage Protection:** 50 V

**Over-current Protection:** 50 mA

**Temperature Stability:** Will not drift more than 10 parts per million per °C from 0°C to 54°C

**Accuracy:** .1% (5 V inputs .16%)

**Listing:** CE Compliant, CSA (File No. LR91109), NRTL/C pending

### Typical Hookups:

**2-Wire 4-20mA Transmitter**

Temperature/Pressure (4-20mA Transmitter)

**3-Wire 0-10V Transmitter**

Flowmeter (0-10 V Transmitter)

**2-Wire 4-20mA Transmitter with Analog Output**

Flowmeter (4-20mA Transmitter)

**Relay Output**

AC Supply

Relay A

Relay B

DC Supply

### DIMENSIONS:

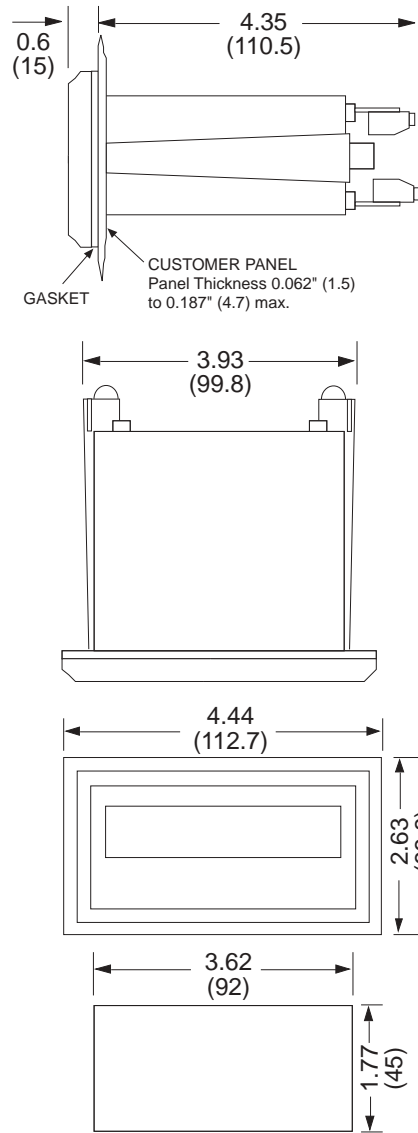

### Wiring:

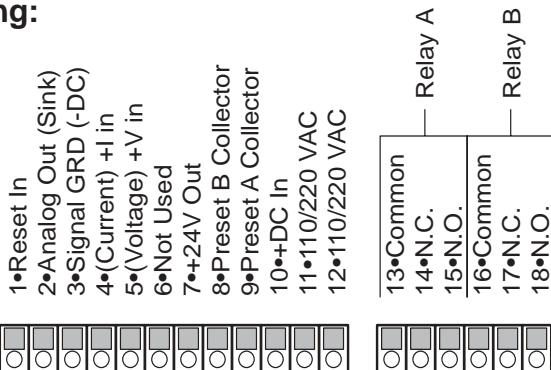

### Ordering Information

**EXAMPLE: INT69PM2 A 1 A**

**Series** INT69PM2= Process Monitor

**Operating Voltage**  
A= 110 VAC ± 15% or 12 to 24 VDC  
B= 220 VAC ± 15% or 12 to 24 VDC

**Control outputs**  
1= 2 - Open Collector Outputs  
2= 2 - 5 Amp Form C Relays

**Options** (multiple options available)  
A= Analog Output (4-20mA)  
C1= RS232 Communications  
C2= RS422 Communications  
CSA: CSA Approved Unit

**Accessories**  
Separate non keyboard panel order #34235  
Separate keyboard panel - order #34234  
Serial printer available, see P1000, P295  
Ethernet Port Server available, see IEPS  
RS-422/485 to RS-232 Communication Adaptor available, see CA285  
XHV Explosion Proof Housing (see Accessories)  
NEMA-1/8DIN NEMA 4 wall mount enclosure (see Accessories)

# Squirt-R

## Loop Powered Indicator

### Features

- Linear or Square Root Extraction of Input
- 3 <sup>1/2</sup> or 4 <sup>1/2</sup> Digit Display (Selectable)
- Calibration, High and Low Values Fully Programmable Through Keypad
- NEMA 4X / IP65 Front
- No Dipswitches or Pots to Adjust
- 16 Bit A/D Resolution
- Password Protection of Menu

### Description:

Featuring up to 4 1/2 digits of display, the Squirt-R is a loop powered indicator capable of accepting either linear or square root 4-20 mA inputs. Numeric password protection prevents unauthorized access to the menu. The easy-to-read menu prompts make the Squirt-R so easy to program that you will feel comfortable programming it without the use of a manual.

### Specifications:

#### Power:

Loop powered 4-20 mA

Internal Battery (Setup memory storage only):

3 V 250 mA-H Lithium (2 yr. Standby life)

#### Display:

Display: (selectable decimal)

3.5 or 4.5 Digits (selectable), 0.35" High, Display updates once every two seconds.

Rate Descriptors: /SEC, /MIN, /HR or "blank"

Units Descriptors: GAL, LIT, FT3, M3, "blank"

Low Battery Error Detection: "BAT" descriptor & flashing display

Under/Over range Indication: Display flashes when out of range

#### Environmental:

OPERATING TEMPERATURE

-4°F (-20°C) to + 158°F (70°C)

Extended Temp: -22°F (-30°C) to + 158°F (70°C)

HUMIDITY

0 - 90% Noncondensing

Listing: CE Compliant



### Accuracy: (Indication @ 20°C)

0.1% Full Scale Resolution

Temperature Drift:

50 ppm/°C Typical

200 ppm/°C Worst Case

### Lockout:

Password: Unauthorized menu changes can be prevented by entering a user selectable password (5 digit number).

Jumper: An internal jumper shunt is provided for a "sealed" menu lockout. Install the jumper to enable the lock.

### Inputs:

Signal Input:

Full Scale Range: 4 to 20 mA DC

Loop Voltage Drop: 6 Volts Maximum

Reverse Polarity Protected

Over Current Protection to 60 mA

16 Bit resolution; 1 sample every 2 seconds

Low Cutoff supplied to inhibit indications at low flow rates.

### Calibration & Operation:

Input Scaling: Via front keypad

Calibration: Via front keypad

Decimal Point: Via front keypad

Keypad: 4 tactile feedback keys

### Mounting Styles:

- |                      |   |
|----------------------|---|
| 0- Circuit Board -   | OEM option (consult factory)  |
| 1- Panel Mount -     | NEMA 4X Clear Front   |
| 2- Wall Mount -      | NEMA 4X Enclosure (unit mounted behind clear cover)                           |
| 3- Explosion Proof - | Class I, Division I, Groups B, C & D<br>Class II, Division I, Groups E, F & G |
| 5- Wall Mount -      | NEMA 4X with keypad mounted outside opaque cover                              |

### SquirtR-0

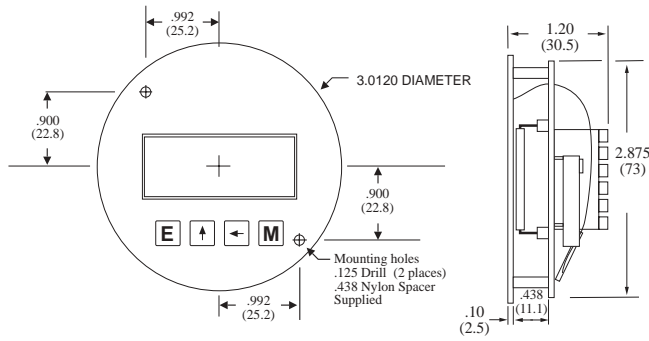

### SquirtR-1

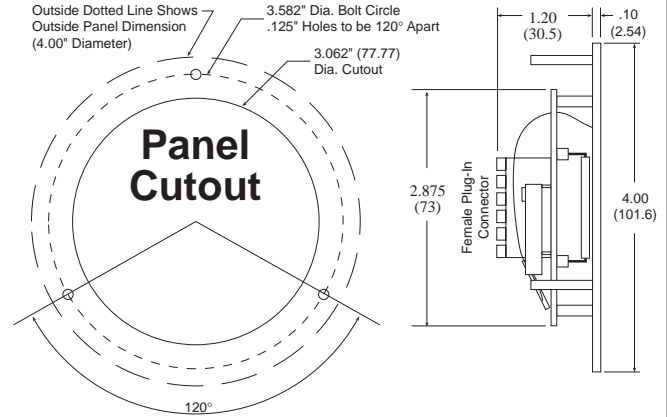

### SquirtR-2

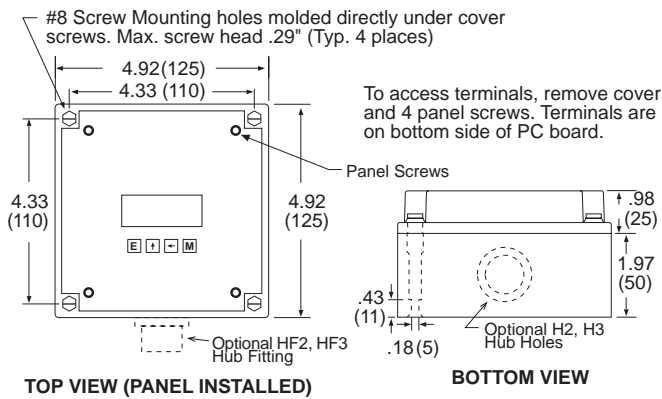

### SquirtR-3

To access terminals, unscrew cover and loosen 2 panel screws. Terminals are on bottom side of PC board.

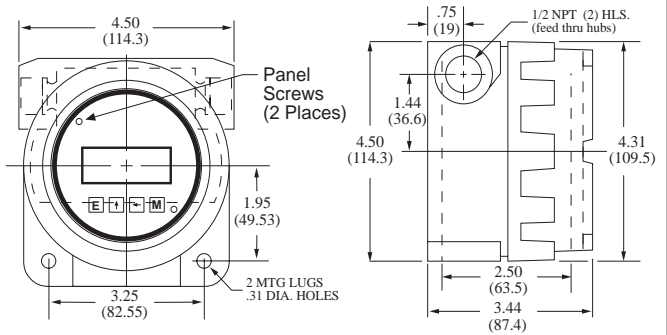

### SquirtR-5

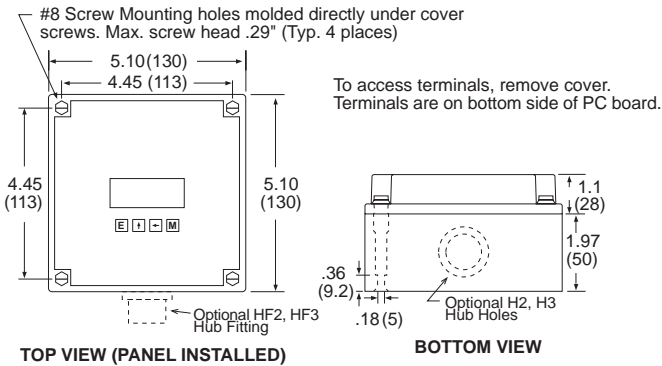

### Typical Wiring: (2-Wire Transmitter)

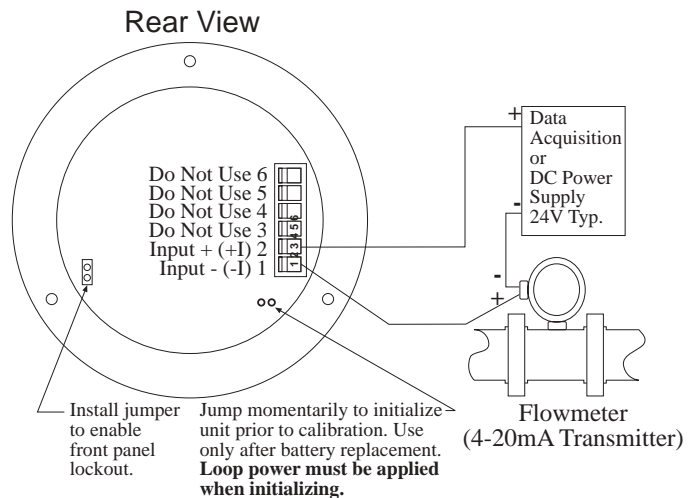

### Ordering Information

Example: **SQUIRTR 3 ET**

SQUIRTR \_\_\_\_\_

Loop powered; Rate Only

Mounting: \_\_\_\_\_

0 = OEM

1 = Panel Mount

2 = NEMA 4X Box (Squirt behind clear cover)

3 = Explosion Proof Housing

5 = NEMA 4X Box (Squirt outside opaque cover)

Options: \_\_\_\_\_

ET = Extended Temp.: -22°F to 158°F (-30°C to 70°C)

H2 = 0.875" Hole for mounting styles 2 and 5

HF2 = 0.5" Female NPT Hub fitting for mounting styles 2 and 5

H3 = 1.125" Hole for mounting styles 2 and 5

HF3 = 0.75" Female NPT Hub fitting for mounting styles 2 and 5



# LEVELtrol II

## Multi-Function Level Indicator, Controller and Batcher

### Features

- Level and Tank Volume/Mass Indicator
- Batching by Level
- Level Control, Tank Volume, Corrected Volume and Mass Calculations
- Menu Selectable Hardware & Software Features
- Two Line LCD or VFD Display
- Isolated Outputs Standard
- RS-232 Port Standard, RS-485 Optional Windows™ Setup Software
- DIN Enclosure with Two Piece Connectors
- DDE Server & HMI Software Available
- NEW! - Attractive Wall Mount Enclosure



### Description:

The LEVELtrol II Flow Computer satisfies the instrument requirements for a variety of level sensor types in liquid applications. Multiple tank geometries, fluid equations and instrument functions are available in a single unit with many advanced features.

The alphanumeric display shows measured and calculated parameters in easy to understand format. Single key direct access to measurements and display scrolling are supported

The versatility of the LEVELtrol II permits a wide measure of versatility within the instrument package. The various hardware inputs and outputs can be "soft" assigned to meet a variety of common application needs. The user "soft selects" the usage of each input/output while configuring the instrument. Consider the following illustrative examples.

The isolated analog output can be chosen to follow level, tank volume, corrected tank volume, tank mass, temperature, or density by means of a menu selection. Most hardware features are assignable by this method.

The user can assign the standard RS-232 Serial Port for data logging, transaction printing, or for connection to a modem for remote meter reading.

### Specifications:

#### Environmental

Operating Temperature: 0°C to +50°C  
Storage Temperature: -40°C to +85 C  
Humidity : 0-95% Non-condensing  
Materials: U.L. approved

**Listing:** UL/C-UL Listed (File No. E192404), CE Compliant

#### Display

Type: 2 lines of 20 characters  
Types: Backlit LCD and VFD ordering options  
Character Size: 0.3" nominal  
User programmable label descriptors and units of measure

#### Keypad

Keypad Type: Membrane Keypad  
Number of keys: 16

#### Enclosure

Style: See Ordering Code for Available Mounting Options  
Size: See Dimensions  
Depth behind panel: 6.5" including mating connector

Type: DIN  
Materials: Plastic, UL94V-0, Flame retardant  
Bezel: Textured per matt finish

### Power Input

The factory equipped power option is internally fused. An internal line to line filter capacitor and MOV are provided for added transient suppression.

110 VAC Power Option: 85 to 127 Vrms, 50/60 Hz  
220 VAC Power Option: 170 to 276 Vrms, 50/60 Hz  
DC Power Option:

12 VDC (10 to 14 VDC)  
24 VDC (14 to 28 VDC)

#### Power Consumption

AC Power: 11.0 V/A (11W)  
DC Power: 300 mA max.

### Level Inputs:

#### Analog Input:

Accuracy: 0.01% FS at 20° C

#### Ranges

Voltage: 0-10 VDC, 0-5 VDC, 1-5 VDC  
Current: 4-20 mA, 0-20 mA

Basic Measurement Resolution: 16 bit

Update Rate: 4 updates/sec

Automatic Fault detection: Signal over/under-range,  
Current Loop Broken

Calibration: Software Calibration (no trimmers) and Auto-zero  
Continuously

#### Extended calibration:

Learns Zero and Full Scale of each range using special test mode.

### Sensor Types Supported:

Differential Pressure, Ultrasonic, Many Others

### Tank Geometries:

Horizontal, vertical, spherical and 32 point strapping table

### Auxiliary / Compensation Input

The auxiliary/compensation input is menu selectable for temperature, density or not used. This input is used for the compensated input when performing compensated tank volume and mass calculations. It can also be used as a general purpose input for display and alarming.

#### Available Input Ranges

Voltage: 0-10 VDC, 0-5 VDC, 1-5 VDC  
Current: 4-20 mA, 0-20 mA  
Resistance: 100 Ohms DIN RTD

**Control Inputs**

Switch Inputs are menu selectable for Start, Stop, Reset, Lock, Alarm Acknowledge, Print or Not Used.

**Relay Outputs**

The relay outputs are menu assignable to Level, Tank Volume, Temperature, Density, Batch Control or Malfunction  
 Number of relays: 2 (4 optional)  
 Contact Ratings: 5 amp, 240 VAC or 30 VDC

**Isolated Analog Output**

The analog output is menu assignable to correspond to the Level, Tank Volume/Mass, Temperature or Density.  
 Type: Isolated 4-20 mA Current Sourcing

**Excitation Voltage** (AC powered units only)  
 24 VDC @ 100 mA (fault protected)

**Isolated Pulse output**

The isolated pulse output is menu assignable to generate pulse outputs when tank fills, empties or both.  
 Pulse Output Form: Isolated Photomos Relay  
 Maximum On Current: 25 mA  
 Maximum Off Voltage: 30 VDC  
 Pulse Duration: 10 msec or 100 msec

**Serial Communication**

The serial port can be used for printing, datalogging, modem connection and communication with a computer. Windows setup software is included for easy programming using a PC.

**RS-232:**

Device ID: 01-99  
 Baud Rates: 300, 600, 1200, 2400, 4800, 9600, 19200  
 Parity: None, Odd, Even  
 Handshaking: None, Software, Hardware  
 Print Setup: Configurable print list and formatting

**RS-485: (coming soon)**

Device ID: 01-247  
 Baud Rates: 300, 600, 1200, 2400, 4800, 9600, 19200  
 Parity: None, Odd, Even  
 Protocol: Modbus RTU (Half Duplex)

**Real Time Clock**

LEVELtrol II is equipped with a battery backed real time clock with display of time and date.

**Format:**

12 or 24 hour time display  
 Day, Month, Year date display

**Fig. 1: Standard Dimensions**

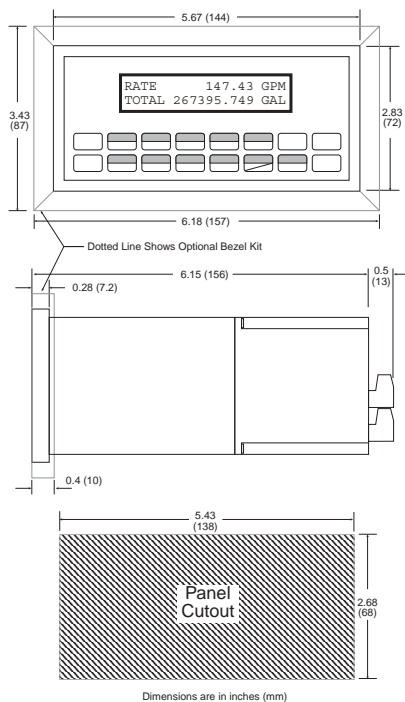

**Fig. 2: Wall Mount ("W" mounting option) Dimensions**

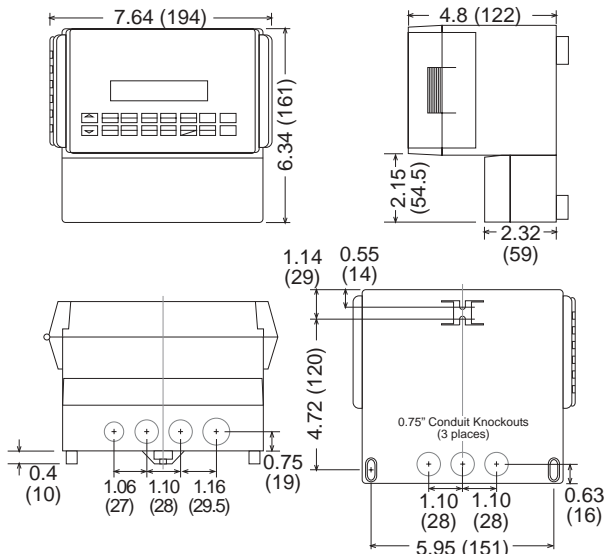

**Terminal Designations:**

LEVEL	IN	COMP	IN	SEE USER	MANUAL	4-20 mA	NC	COM RLY3	NC	COM RLY4	POWER IN	
DC OUTPUT	Vin +	RTD EXCIT +	RTD SENS +	Vin +	lin +	PULSE OUTPUT +	25	26	27	28	29	30
1	2	3	4	5	6	7	8	9	10	11	12	13
17	18	19	20	21	22	23	24	DC +	DC -			

**Ordering Information**

**Example** LT2 L 1 B 0 P

- Series:** LT2 = LEVELtrol II
- Display Type:** L = LCD, V = VFD
- Input Type:** 1 = 110 VAC, 2 = 220 VAC, 3 = 12 VDC (10 to 14 VDC), 4 = 24 VDC (14 to 28 VDC)
- Relays:** A = 2 SPDT Relays, B = 4 SPDT Relays
- Network Card:** 0 = None (STD), 2 = RS485/Modbus (available soon) (optional 2nd COM port)
- Mounting:** P = Panel Mount (see Fig. 1), N = NEMA 4 Wall Mount (see NEMA4rolST4X), W = NEMA 12/13 Wall Mount w/ Clear Cover (see Fig.2), E = Explosion Proof (No Button Access) (see XTROL 7/4), X = Explosion Proof (with Button Access) (see XTROL 7/4)
- Options:** ET = Extended Temperature (-4°F to 131°F (-20°C to 55°C)), IM = Internal Modem, M = Modem Power Option

**Accessories:**  
 KEPS-KEP1-32 = KEP RS232 for SUPERtrol 1, SUPERtrol 1LE, SUPERtrol 2 and LEVELtrol 2 • 32 Bit DDE Server  
 Modem Available, see MPP-2400N (requires M option)  
 Serial printer available, see P1000, P295  
 Ethernet Port Server available, see IEPS  
 RS-422/485 to RS-232 Communication Adaptor available, see CA285  
 Remote metering and data collection software available, see TROLLink

# Field Indicators Tutorial

Field indicators are signal conditioner/converter devices with a display. Field Indicators are intended for mounting on or near the flow sensor. They perform many of the same roles of signal conditioner/converters plus that of providing a convenient local display.

Many “smart” Field Indicators provide additional, advanced functionality such as sensor linearization.

Field Indicators are ancillary display devices also intended to amplify, filter, condition, scale, and convert the low level “raw” signals produced by many transducers and convert it into the desired, industry standard high level signal before transmitting it across a potentially noisy environment. Display indication is also provided. In some cases, a secondary function is providing signal isolation.

Generally, the output signals may be in the form of either a pulse and/or analog current/voltage that is proportional to the span of the signal being measured. Open collector transistors are common as pulse output signals. The most common analog signal is a 4-20mA current signal.

In many flowmeter types the frequency of the raw input signal carries the flow information. The frequency is related to flow rate. Each pulse or cycle is related to a small equivalent quantity of flow. The quantity represented by each pulse varies with each individual meter and must be scaled to obtain engineering units.

The input signal to a pulse signal conditioner may be a contact closure, a magnetic pickup, or a low level pulse. Some conditioner/converters scale the pulse signal such that each pulse represents a engineering quantity of flow, for example 1 pulse per gallon). Some converters convert the variable frequency signal into a current proportional to flow rate.

In many cases, the field indicator is intended to be powered either by an internal battery, or by the 4-20mA output current loop, or by a DC supply voltage normally available in most instruments with 24 VDC being the most common.

Enclosures are available for outdoor weatherproof and also hazardous locations. Most have provisions for mounting on the flowmeter and/or near the flowmeter.

Field Rate/Total Indicators are applied in most PLC and PC based control systems to adapt the process signals into the standardized levels provides on I/O Cards while at the same time providing a display of information in the field.

## Typical Application

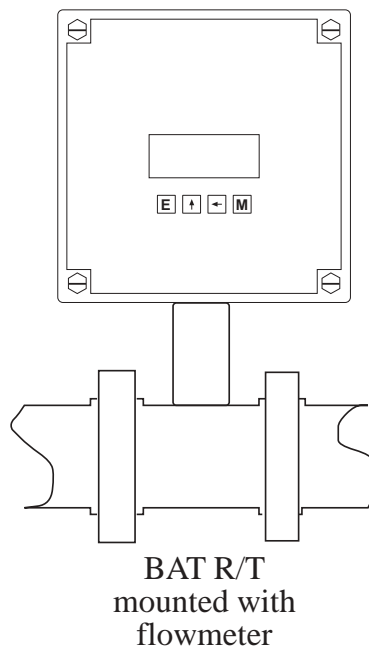

# SQUIRT

## Loop Powered Indicator

### Features

- Linear or Square Root Extraction of Input
- 3 <sup>1/2</sup> or 4 <sup>1/2</sup> Digit Rate Display (Selectable)
- 8 Digit Totalizer Display
- Calibration, High and Low Values Fully Programmable Through Keypad
- No Dipswitches or Pots to Adjust
- 16 Bit A/D Resolution
- Isolated Scaled Pulse Output
- Password Protection of Menu and Totalizer

### Description:

Featuring up to 4<sup>1/2</sup> digits of rate and 8 digits of total, the Squirt is a loop powered indicator capable of accepting either linear or square root 4-20 mA inputs. An isolated scaled pulse output is available for hook up to a remote totalizer. Numeric password protection prevents unauthorized access to menu. The easy-to-read menu prompts make the Squirt so easy to program that you will feel comfortable programming it without the use of a manual.

### Specifications:

#### Power:

Loop powered 4-20 mA  
Internal Battery (Setup & totalizer memory storage only):  
3 V 250 mA-H Lithium (2 yr. Standby life)

#### Display:

Rate Display: (selectable decimal)  
3.5 or 4.5 Digits (selectable), 0.35" High, Display updates once every two seconds.

Rate Descriptors: /SEC, /MIN, /HR or "blank"

Totalizer Display: (selectable decimal)

8 Digits (99999999), 0.2" High

Totalizer Descriptors: GAL, LIT, FT3, M3, "blank"

Low Battery Error Detection: "BAT" descriptor

Under/Over range Indication: Flashing display

#### Environmental:

##### OPERATING TEMPERATURE

-4°F (-20°C) to + 158°F (70°C)

Extended Temp: -22°F (-30°C) to + 158°F (70°C)

##### HUMIDITY

0 - 90% Noncondensing

#### Accuracy: (Rate @ 20°C)

0.1% Full Scale Resolution, ±1 count

#### Temperature Drift:

50 ppm/°C Typical

200 ppm/°C Worst Case

#### Listing: CE Compliant



### Inputs:

#### Signal Input:

Full Scale Range: 4 to 20 mA DC

Loop Voltage Drop: 6 Volts Maximum

Reverse Polarity Protected

Over Current Protection to 60 mA

16 Bit resolution; 1 sample every 2 seconds

Low Cutoff supplied to inhibit indications at low flow rates.

#### Reset Input: (contact closure)

Internal Pullup Resistor: 100 kΩ to +3 VDC

High (logic 1): Open or 3-30 VDC

Low (logic 0): Less Than .5 VDC

Minimum On : 25 msec

### Pulse Output:

The pulse output advances with the least significant digit of the totalizer.

Type: Opto-isolated open collector transistor.

Max. voltage (off state): 30 VDC

Current (on state): 5 mA @ .9 V drop, .1mA @ .7 drop

Pulse Duration: 15 msec

Pulse Output Rate: 25 CPS max.

Pulse output divider: User selectable, +1, +10, +100 or off

### Calibration & Operation:

Input Scaling: Via front keypad

Calibration: Via front keypad

Decimal Point: Via front keypad

Reset Input: Via front keypad or remote dry contact closure

Keypad: 4 tactile feedback keys

### Mounting:

0- Circuit Board -

OEM option (consult factory)

1- Panel Mount -

NEMA 4X Clear Front

2- Wall Mount -

NEMA 4X Enclosure with Squirt mounted behind clear cover

3- Explosion Proof -

Class I, Division I, Groups B, C & D

Class II, Division I, Groups E, F & G

5- Wall Mount -

NEMA 4X with Squirt mounted outside opaque cover

## Wiring:

### 2-Wire Transmitter

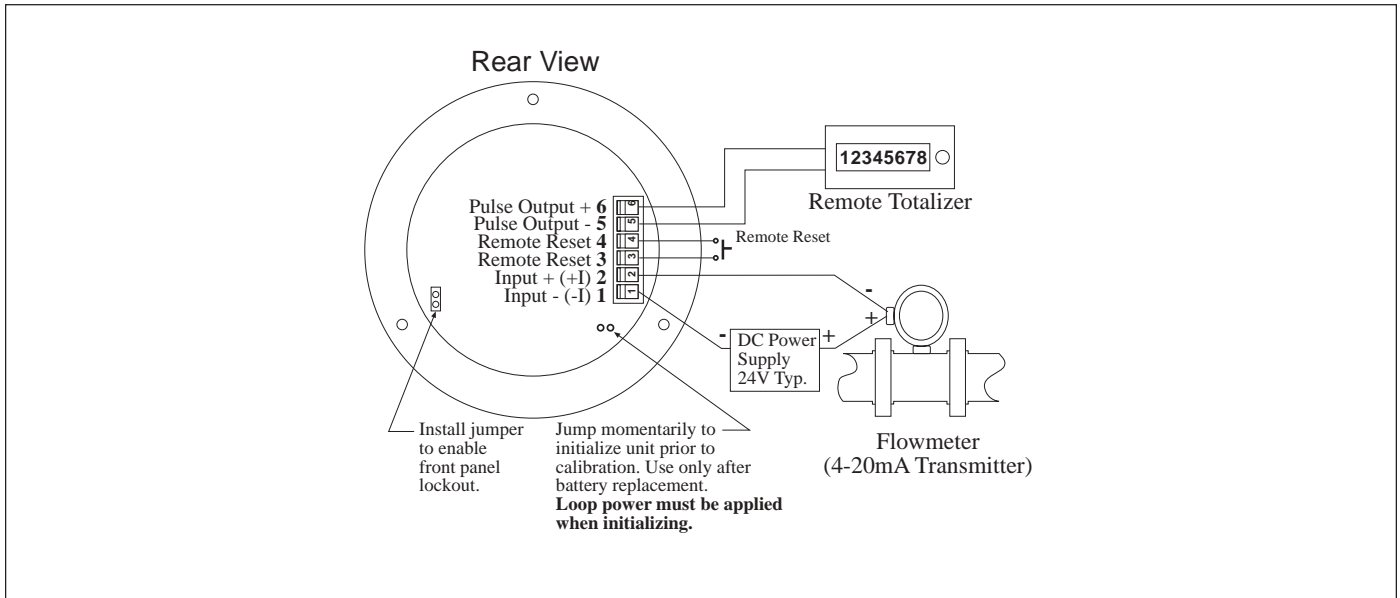

### 4-Wire Transmitter

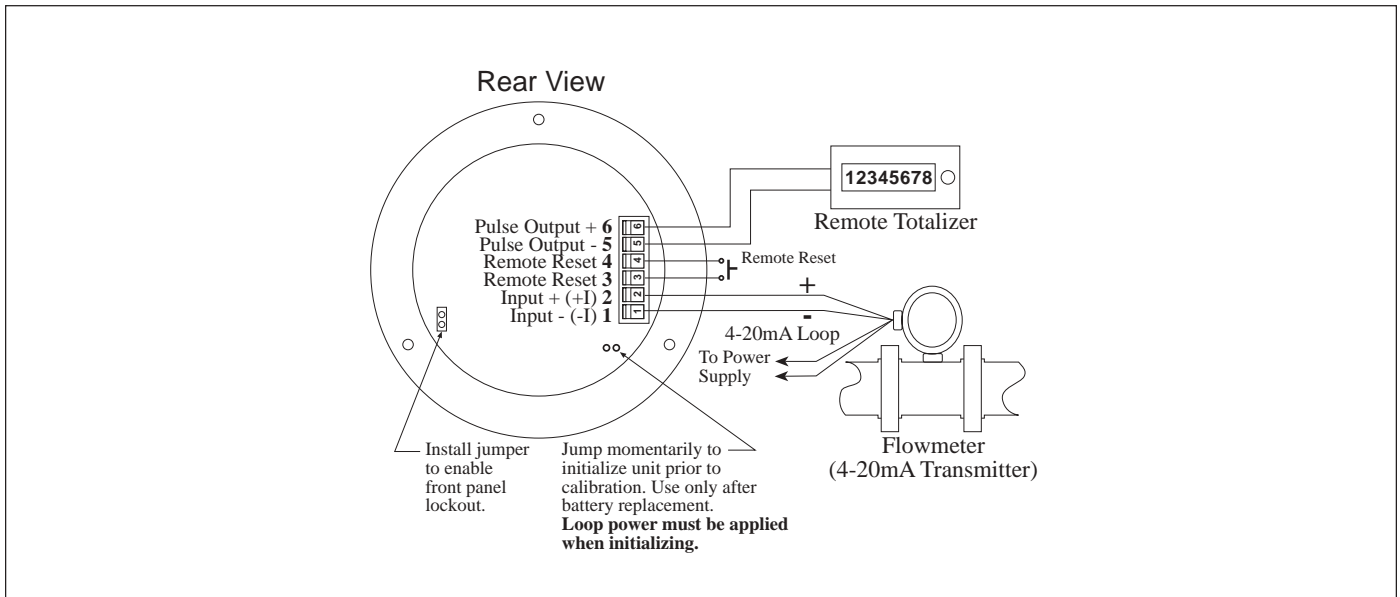

### Squirt-0

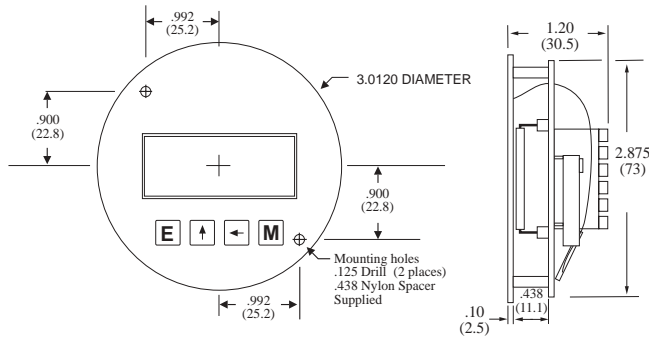

### Squirt-1

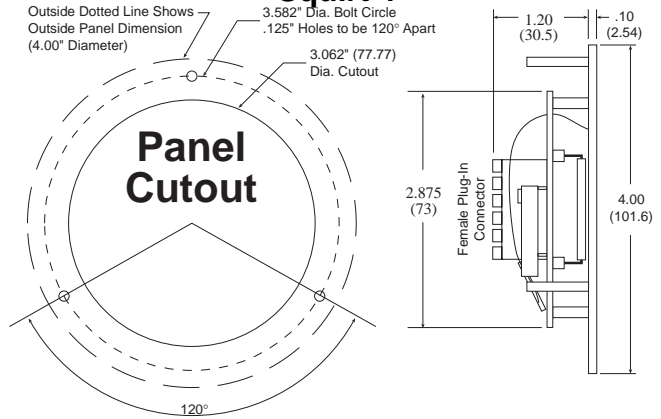

### Squirt-2

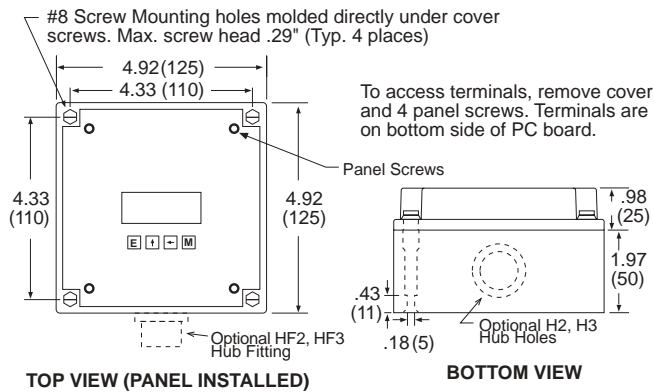

### Squirt-3

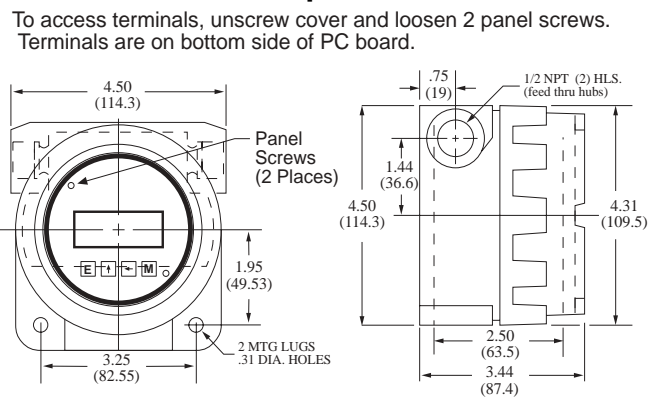

### Squirt-5

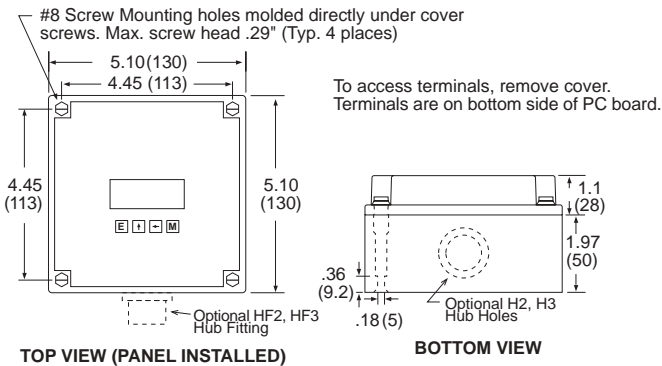

### Ordering Information

**Example:**        **SQUIRT**        **3**        **ET**

SQUIRT \_\_\_\_\_  
 Loop powered; Rate & Total

Mounting: \_\_\_\_\_  
 0 = OEM  
 1 = Panel Mount  
 2 = NEMA 4X Box (Squirt behind clear cover)  
 3 = Explosion Proof Housing  
 5 = NEMA 4X Box (Squirt outside opaque cover)

Options: \_\_\_\_\_  
 ET = Extended Temp.: -22°F to 158°F (-30°C to 70°C)  
 R = External Magnetic Reset  
     for NEMA4X & Explosion Proof Enclosures  
 RX = NEMA7 Explosion Proof Reset Switch  
     for Explosion Proof Enclosure with  
     3/4" straight thread side entry  
 H2 = 0.875" Hole for mounting styles 2 and 5  
 HF2 = 0.5" Female NPT Hub fitting for mounting styles 2 and 5  
 H3 = 1.125" Hole for mounting styles 2 and 5  
 HF3 = 0.75" Female NPT Hub fitting for mounting styles 2 and 5

# BAT R/T MILLENNIUM

## Battery or Loop Powered Ratemeter & Totalizer

### Features

- Accepts Inputs From: Magnetic Pickups, Contact Closures, DC Pulses (Optically Isolated) from Pulse Producing Flowmeters
- Displays Rate & Total Simultaneously  
5 Digit Rate Display, 8 Digit Totalizer Display
- 4-20mA Analog Output Option (8 updates/sec)
- Powered From Internal Battery, External DC Supply or 4-20 mA Output Loop
- 20 Point Linearization (optional);  
10 Point Linearization with Data Logger option
- Isolated Scaled Pulse Output
- Nonvolatile Flash Memory of Setup Data
- RS232 Serial Communications (optional)



- RS485 Modbus Communications and Data Logger (optional)
- Setup Software Available for Easy Programming and Monitoring Using a PC
- Extended Battery Life
- Direct Meter Mounting Kit (optional)

Flow Instruments  
FIELD INDICATORS

### Description

Featuring 5 digits of rate and 8 digits of total, the BAT R/T Millennium edition (BATRT-M) is a battery or loop powered indicator capable of accepting magnetic pickup, DC pulse and switch closure inputs from pulse producing flowmeters. The unit can be ordered with an optional 4-20mA output. The BATRT-M uses the 4-20mA loop to provide power when this output is used.

### Specifications

#### Power:

##### BATTERY POWERED

Supplied with 1 or 2 C size Lithium battery pack.

##### EXTERNAL POWER INPUT

Voltage: 8.5 to 30 VDC

Current: Less than 5 mA

Supplied with 1 C size lithium battery

Protection: Reverse Polarity Protection on DC Power Input

##### LOOP POWERED

Voltage: 8.5 to 30 VDC

Supplied with 1 or 2 C size lithium battery(ies)

Protection: Reverse Polarity Protection on Current Loop

Loop Burden: 8.5V maximum

### BATTERY LIFE EXPECTANCY:

Expected Years of Operation for BATRT-M of various powering options at equipment duty cycles

#### MODEL

#### RUN TIME

	Idle	2hrs/day	8hrs/day	24hrs/day
BATRT-M-A	10 yrs	10 yrs	10 yrs	9.1 yrs
BATRT-M-A-4	10 yrs	10 yrs	10 yrs	8.4 yrs
BATRT-M-B/C	10 yrs	10 yrs	10 yrs	10 yrs
<b>standby-operation</b>				
BATRT-M -B/C	Indefinite operation when externally powered			
External or loop power				

**NOTE:** Battery shelf life is rated at 10 years by manufacturer. Life expectancy based on rated battery capacity at 20°C. The above table is shown with pulse output inactive. Use of pulse output shortens battery life. Example: A pulse output of 0.06 sec. duration, once per second, would derate the battery life by 20%.

\* A large delay setting and internal math operations may delay the update rate.

### DISPLAY:

Rate Display: (selectable decimal)

5 Digits (99999), 0.35" High, Display updates once per second with battery power, 8X per second with DC or Loop power

Rate Descriptors: /SEC, /MIN, /HR

/MIN, /HR, /DAY with "D" option

Min. Input Frequency: 0.01 Hz to 10 Hz (selectable delay of 0.1 to 99.9 seconds)\*

Selectable Rate Display Damping

Totalizer Display: (selectable decimal)

8 Digits (99999999), 0.2" High

Totalizer Descriptors: GAL, LIT, FT3, M3, "blank"

GAL, BBL, MCF, M3, "blank" with "D" option

Warning Displays: Low battery warning

### PULSE OUTPUT:

The pulse output advances with the least significant digit of the totalizer or decimal multiples thereof (see Pulse scale divider).

Type: Isolated photomos relay

Max. voltage (off state): 30 VDC

Current (on state): 100mA

Pulse Duration: Selectable 0.5, 0.25, 0.125, 0.0625 seconds

Pulse Scale divider (Pulscale): User selectable, +1, +10, +100 or OFF

NOTE: Select OFF for max. battery life.

### ACCURACY:

0.01% Reading, ±1 count

Temperature Drift: 50 ppm/°C Worst Case

### ENVIRONMENTAL:

OPERATING TEMPERATURE

-4°F (-20°C) to +158°F (70°C)

Extended Temp: -22°F (-30°C) to +158°F (70°C)

HUMIDITY

0 - 90% Noncondensing

**MOUNTING STYLES:**

- 0- Circuit Board- OEM option (consult factory)
- 1- Panel Mount - NEMA 4X Front
- 2- Wall Mount - NEMA 4X Enclosure  
(keypad mounted behind clear cover)
- 3- Explosion Proof - Class I, Division I, Groups B, C & D  
Class II, Division I, Groups E, F & G
- 5- Wall Mount - NEMA 4X Enclosure  
(keypad mounted on cover)
- 6- Double Ended Explosion Proof - Class I, Division I, Groups B, C & D  
Class II, Division I, Groups E, F & G  
(contact factory for details)

**NOTE:** Meter mounting kits available for styles 2, 3 and 5

**INPUTS:**

**MAGNETIC PICKUP INPUT**

Frequency Range: 0 to 3500 Hz  
Trigger Sensitivity: 30 mV p-p (10 mV p-p on special order)  
Over Voltage Protected: ± 30 VDC

**OPTO-ISOLATED DC PULSE INPUT**

High (logic 1): 4-30 VDC  
Low (logic 0): Less Than 1 VDC  
Minimum Current: .5 mA  
Hysteresis: 0.4 VDC  
Frequency Range: 0 to 5 kHz  
Min. Pulse Width: 0.1 msec

**CONTACT CLOSURE INPUT (contact closure to common)**

Internal Pullup Resistor: 100 KΩ to +3.6 VDC  
High (logic 1): Open or 4-30 VDC  
Low (logic 0): Less Than .5 VDC  
Internal Switch Debounce Filter: 0 to 40 Hz

**NOTE:** Sustained contact closure will shorten battery life.

**RESET INPUT (contact closure to common)**

Internal Pullup Resistor: 100 KΩ to +3.6 VDC  
High (logic 1): Open or 4-30 VDC  
Low (logic 0): Less Than .5 VDC  
Minimum On : 25 msec

**NOTE:** Sustained contact closure will shorten battery life.

**K-FACTOR**

Range: 0.001 to 99999999  
Decimal Point Locations: XXXX.XXXX to XXXXXXXX

**20 Point Linearization Option (10 Point with Data Logger option)**

This feature allows the user to enter 20 different frequencies with 20 different corresponding K-Factors to linearize non linear signals.

**ANALOG OUTPUT OPTION:**

Type: 4-20 mA follows rate display, Two wire hookup  
Accuracy: 0.025% Full Scale at 20° C  
Temperature Drift:  
50 ppm/°C Typical  
Reverse Polarity Protected  
Update Rate: 8 times/second

**NOTE:** The BATRT-M uses the 4-20 mA loop power as its primary power source when this option is used. The battery is still required for standby battery operation.

**COMMUNICATIONS OPTION (S1):**

**RS232 SERIAL SETUP SOFTWARE OPTION:**

This option enables you to access a variety of process parameters through serial communications. PC compatible communications software is included with this option. With this software and a BAT R/T-M Serial Adapter Cable (BSAC1) you will be able to setup the BAT R/T-M through your PC.

**RS-485 MODBUS and DATA LOGGER OPTION (S2):**

The optional RS-485 card utilizes Modbus RTU protocol to access a variety of process parameters. The Data Logger stores the totalizer to flash memory once every 24 hours at the time you set.

**DATA STORAGE:**

Setup Information: Stored in flash memory  
Totalizer: Stored in battery backed RAM but can be saved to flash memory by operator for recall after battery change out.

**Typical Wiring:**

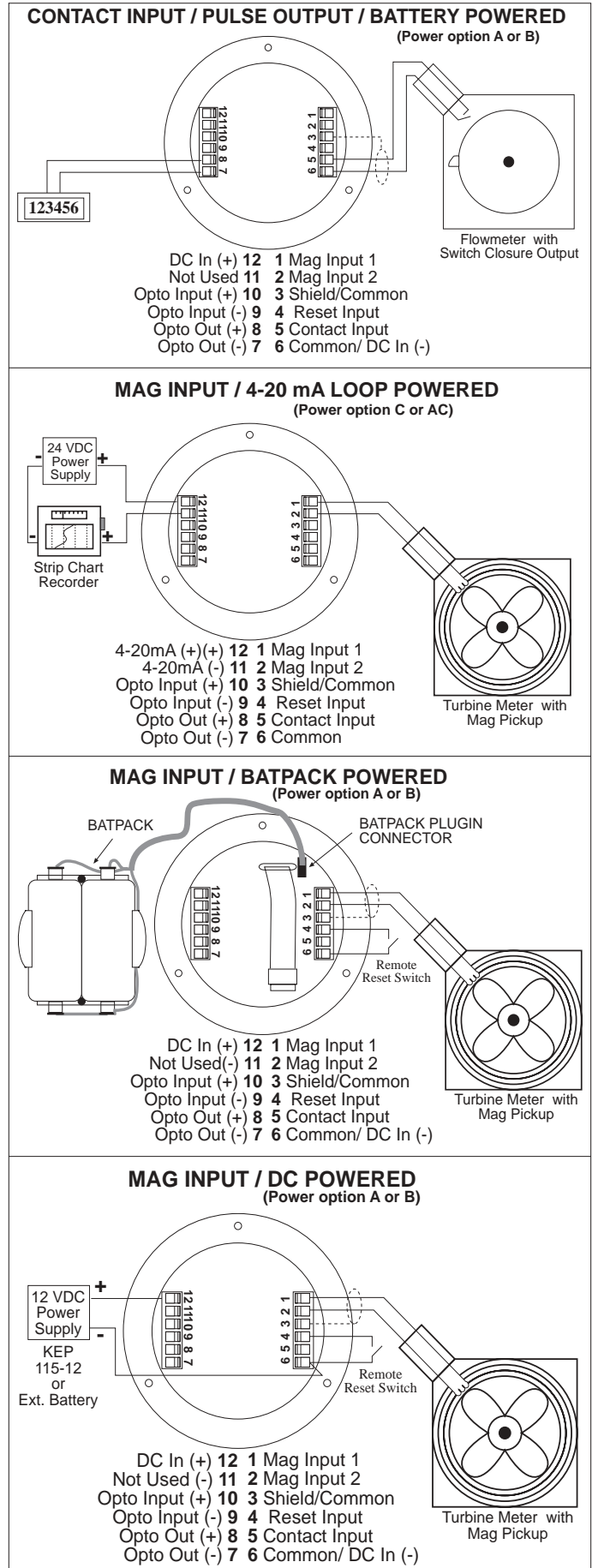



### BATPACK

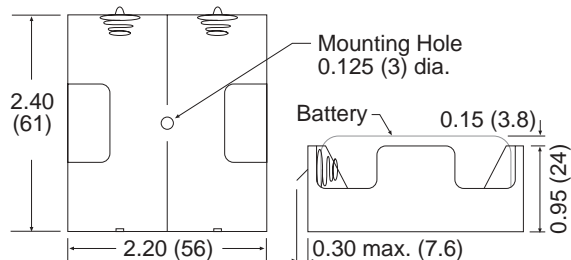

### BATRT-M-0

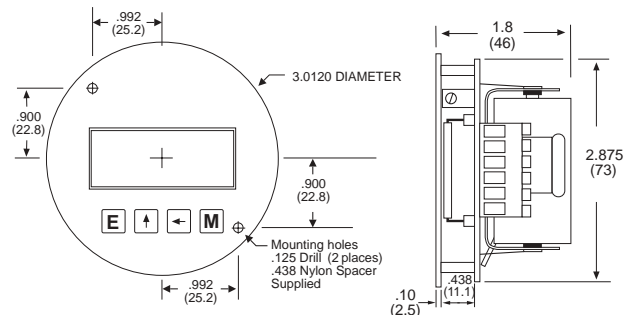

### BATRT-M-1

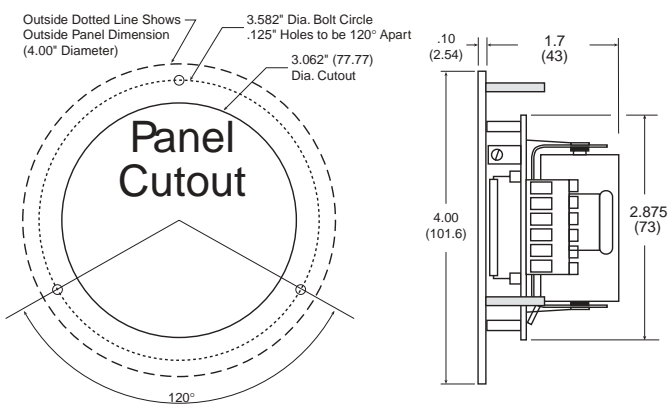

### BATRT-M-2

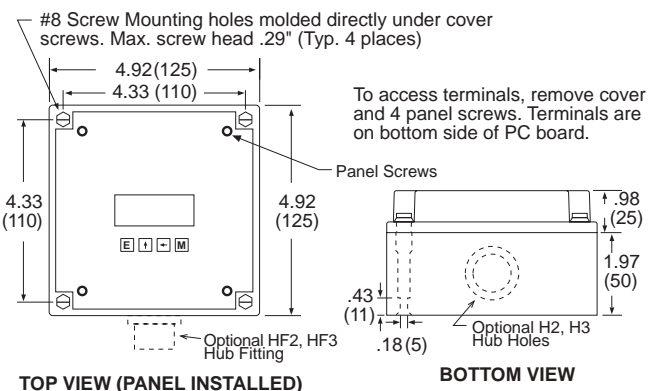

### BATRT-M-3

To access terminals, unscrew cover and loosen 2 panel screws. Terminals are on bottom side of PC board.

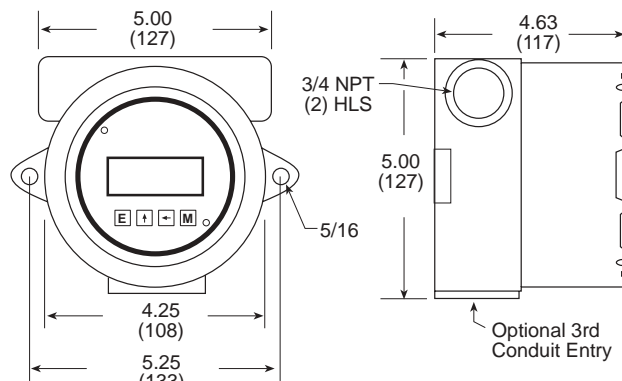

### BATRT-M-5

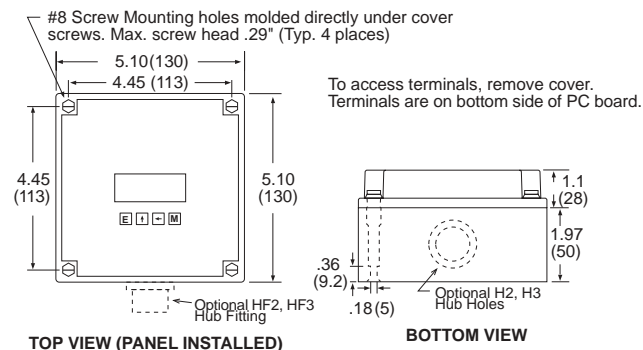

## Ordering Information

**EXAMPLE:** BATRTM 3 A 4 ET

- Series:** \_\_\_\_\_
- Mounting:** \_\_\_\_\_
- \* 0 = OEM
  - \* 1 = Panel Mount
  - 2 = NEMA 4X Box (Bat R/T behind clear cover)
  - 3 = Explosion Proof Housing
  - 5 = NEMA 4X Box (Bat R/T outside opaque cover)
  - 6 = Double Ended Explosion Proof Housing (consult factory)
- Power Supply:** \_\_\_\_\_
- \* A = Battery (2 supplied)
  - B = External Power Supply (8.5 to 30 VDC)
  - C = Loop Powered with 4-20 mA Output
  - AC = Loop Powered with 4-20 mA Output and 2 Batteries

- Options** (Multiple Options Available) \_\_\_\_\_
- S1 = Serial Setup Software
  - S2 = RS485/Modbus/Data Logger - Isolated
  - 4 = 20 Point Linearization (10 point with S2 option)
  - D = Rate per Day, Hour or Minute
  - ET = Extended Temp.: -22°F to 158°F (-30°C to 70°C)
  - CE\*\* = CE Compliant
  - CSA\*\* = CSA Listed Explosion Proof (planned)
  - IS\*\* = UL Listed IS (planned)
  - TRX = NEMA7 Explosion Proof Reset Switch
  - RN = External Magnetic Reset
  - T = Third Conduit Entry in Ex-Proof Housing
  - H2 = 0.875" Hole for mounting styles 2 and 5
  - HF2 = 0.5" Female NPT Hub fitting for mounting styles 2 and 5
  - H3 = 1.125" Hole for mounting styles 2 and 5
  - HF3 = 0.75" Female NPT Hub fitting for mounting styles 2 and 5

- Accessories:**
- BATPACK= External Batt. Pack with 2 C Size Batteries & 12" leads
  - BATC = Single Battery: Tadiran P/N TL2200/S 3.6V 7200mAh or equal
  - 115-24 = 115 VAC to 24 VDC power supply
  - BSAC1 = RS232 Serial Adapter Cable

\* External battery pack supplied with models BATRTM0A & BATRTM1A  
 \*\* Contact factory for latest information

# BAT RAT MILLENNIUM

## Features

- Magnetic Pickup Input, Contact Closure Input, DC Pulse Input (Optically Isolated)
- Displays Rate & Total Simultaneously
- 5 Digit Rate Display, 8 Digit Totalizer Display
- 4-20mA Analog Output (optional)
- Powered From Internal Battery, External DC Supply or 4-20 mA Output Loop
- 20 Point Linearization (optional); 10 Point Linearization with Data Logger option
- Isolated High/Low Flow Rate Alarm Output
- Nonvolatile Flash Memory of Setup Data
- Extended Battery Life

## Battery Powered Ratemeter & Totalizer with Alarm Output



- RS232 Serial Communications (optional)
- RS485 Modbus Communications and Data Logger (optional)
- Setup Software Available for Easy Programming and Monitoring Using a PC

## Description

Featuring 5 digits of rate and 8 digits of total, the BAT RAT Millennium (BATRAT-M) is a battery powered indicator with flow rate alarm output. It is capable of accepting magnetic pickup, DC pulse and switch closure inputs from pulse producing flowmeters.. The unit can be ordered with an optional 4-20mA output. The BAT RAT uses the 4-20mA loop to provide power when this output is used.

## Specifications

### Power:

#### BATTERY POWERED

Supplied with 2 C size Lithium battery pack.

#### EXTERNAL POWER INPUT

Voltage: 8.5 to 30 VDC

Current: Less than 5 mA

Supplied with 1 C size lithium battery for standby operation

Protection: Reverse Polarity Protection on DC Power Input

#### LOOP POWERED

Voltage: 8.5 to 30 VDC

Supplied with 1 C size lithium battery for standby operation

Protection: Reverse Polarity Protection on Current Loop

Loop Burden: 8.5V maximum

### BATTERY LIFE EXPECTANCY:

Expected Years of Operation for BATRAT-M of various powering options at equipment duty cycles

MODEL	RUN TIME			
	Idle	2hrs/day	8hrs/day	24hrs/day
BATRAT-M-A	10 yrs	10 yrs	10 yrs	9.1 yrs
BATRAT-M-A-4	10 yrs	10 yrs	10 yrs	8.4 yrs
BATRAT-M-B/C	10 yrs	10 yrs	10 yrs	10 yrs
standby-operation				
BATRAT-M -B/C	Indefinite operation when externally powered			
External or loop power				

**NOTE:** Battery shelf life is rated at 10 years by manufacturer  
 Life expectancy based on rated battery capacity at 20°C  
 The above table is shown with pulse output inactive. Use of pulse output shortens battery life.  
 Example: A pulse output of 0.06 sec. duration, once per second, would derate the battery life by 20%.

## Display:

Rate Display: (selectable decimal)

5 Digits (99999), 0.35" High, Display updates once per second with battery power, 8X per second with DC or Loop power

Rate Descriptors: /SEC, /MIN, /HR

/MIN, /HR, /DAY with "D" option

Min. Input Frequency: 0.01 Hz to 10 Hz (selectable delay of 0.1 to 99.9 seconds)\*

Selectable Rate Display Damping

Totalizer Display: (selectable decimal)

8 Digits (99999999), 0.2" High

Totalizer Descriptors: GAL, LIT, FT3, M3, "blank"

GAL, BBL, MCF, M3, "blank" with "D" option

Warning Displays: Low battery warning

## Alarm Output:

Combination High-Low flow rate alarm output activates when flow rate is less than low set point or greater than high set point.

Type: Opto-isolated photomos relay

Max. voltage (off state): 100 VDC

Current (on state): 100 mA

## Mounting Styles:

- 0- Circuit Board - OEM option (consult factory)
- 1- Panel Mount - NEMA 4X Front
- 2- Wall Mount - NEMA 4X Enclosure with BAT RAT mounted behind clear cover
- 3- Explosion Proof - Class I, Division I, Groups B, C & D  
Class II, Division I, Groups E, F & G
- 5- Wall Mount - NEMA 4X with keypad mounted outside opaque cover

**Environmental:**

**OPERATING TEMPERATURE**

-4°F (-20°C) to + 158°F (70°C)

Extended Temp: -22°F (-30°C) to + 158°F (70°C)

**HUMIDITY**

0 - 90% Noncondensing

**ACCURACY:**

0.01% Reading, ±1 count

Temperature Drift: 50 ppm/°C Worst Case

**ENVIRONMENTAL:**

**OPERATING TEMPERATURE**

-4°F (-20°C) to + 158°F (70°C)

Extended Temp: -22°F (-30°C) to + 158°F (70°C)

**HUMIDITY**

0 - 90% Noncondensing

**MOUNTING STYLES:**

- 0-** Circuit Board - OEM option (consult factory)
- 1-** Panel Mount - NEMA 4X Front
- 2-** Wall Mount - NEMA 4X Enclosure  
(keypad mounted behind clear cover)
- 3-** Explosion Proof - Class I, Division I, Groups B, C & D  
Class II, Division I, Groups E, F & G
- 5-** Wall Mount - NEMA 4X Enclosure  
(keypad mounted on cover)
- 6-** Double Ended Explosion Proof -  
Class I, Division I, Groups B, C & D  
Class II, Division I, Groups E, F & G  
(contact factory for details)

**NOTE:** Meter mounting kits available for styles 2, 3 and 5

**INPUTS:**

**MAGNETIC PICKUP INPUT**

Frequency Range: 0 to 3500 Hz

Trigger Sensitivity: 30 mV p-p (10 mV p-p on special order)

Over Voltage Protected: ± 30 VDC

**OPTO-ISOLATED DC PULSE INPUT**

High (logic 1): 4-30 VDC

Low (logic 0): Less Than 1 VDC

Minimum Current: .5 mA

Hysteresis: 0.4 VDC

Frequency Range: 0 to 5 kHz

Min. Pulse Width: 0.1 msec

**CONTACT CLOSURE INPUT (contact closure to common)**

Internal Pullup Resistor: 100 KΩ to +3.6 VDC

High (logic 1): Open or 4-30 VDC

Low (logic 0): Less Than .5 VDC

Internal Switch Debounce Filter: 0 to 40 Hz

**NOTE:** Sustained contact closure will shorten battery life.

**RESET INPUT (contact closure to common)**

Internal Pullup Resistor: 100 KΩ to +3.6 VDC

High (logic 1): Open or 4-30 VDC

Low (logic 0): Less Than .5 VDC

Minimum On : 25 msec

**NOTE:** Sustained contact closure will shorten battery life.

**K-FACTOR**

Range: 0.001 to 99999999

Decimal Point Locations: XXXX.XXXX to XXXXXXXX

**20 Point Linearization Option (10 Point with Data Logger option)**

This feature allows the user to enter 20 different frequencies with 20 different corresponding K-Factors to linearize non linear signals.

**ANALOG OUTPUT OPTION:**

Type: 4-20 mA follows rate display, Two wire hookup

Accuracy: 0.025% Full Scale at 20° C

Temperature Drift:

50 ppm/°C Typical

Reverse Polarity Protected

Update Rate: 8 times/second

**NOTE:** The BATRT-M uses the 4-20 mA loop power as its primary power source when this option is used. The battery is still required for standby battery operation.

**COMMUNICATIONS OPTION (S1):**

**RS232 SERIAL SETUP SOFTWARE OPTION:**

This option enables you to access a variety of process parameters through serial communications. PC compatible communications software is included with this option. With this software and a BATRAT-M Serial Adapter Cable (BSAC1) you will be able to setup the BATRAT-M through your PC.

**RS-485 MODBUS and DATA LOGGER OPTION (S2):**

The optional RS-485 card utilizes Modbus RTU protocol to access a variety of process parameters. The Data Logger stores the totalizer to flash memory once every 24 hours at the time you set.

**DATA STORAGE:**

Setup Information: Stored in flash memory

Totalizer: Stored in battery backed RAM but can be saved to flash memory by operator for recall after battery change out.

### BATPACK

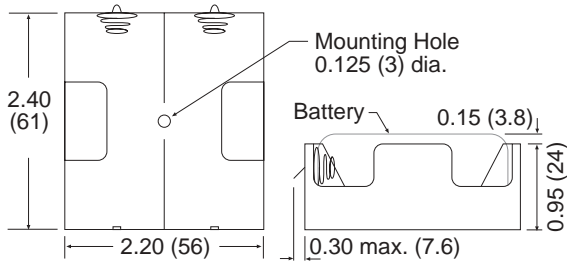

### BATRAT-M-0

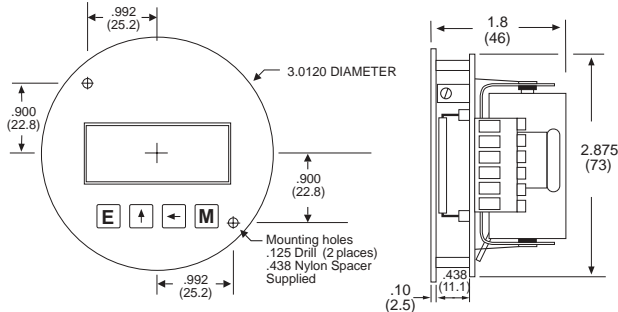

### BATRAT-M-1

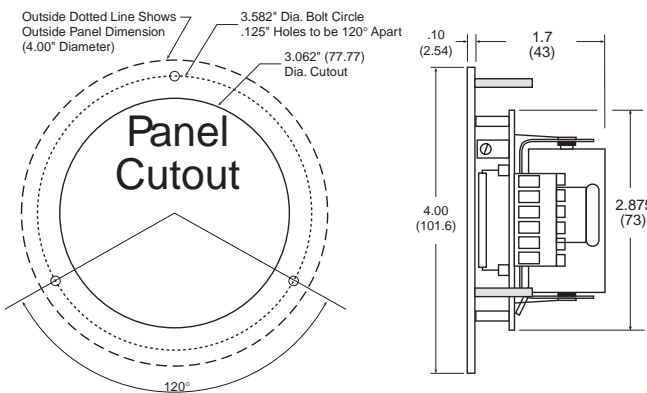

### BATRAT-M-2

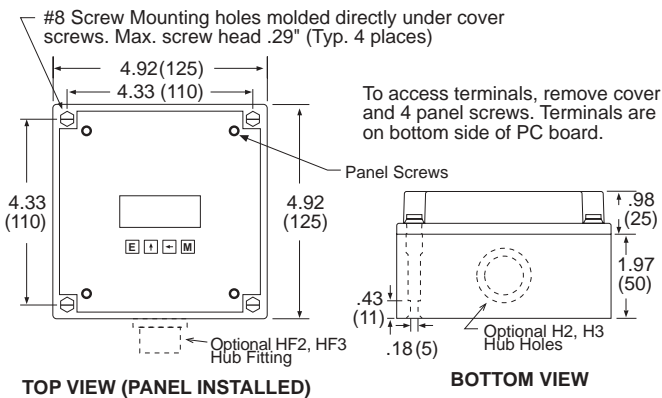

### BATRAT-M-3

To access terminals, unscrew cover and loosen 2 panel screws. Terminals are on bottom side of PC board.

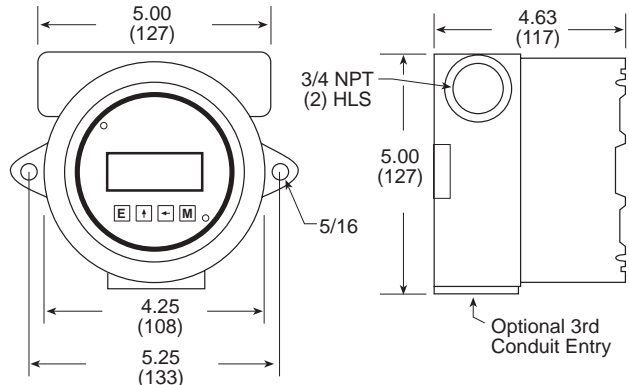

### BATRAT-M-5

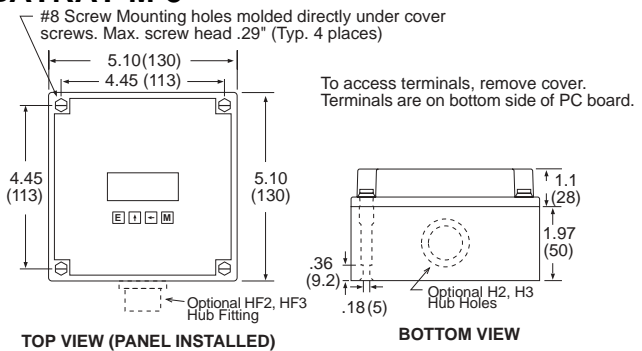

## Ordering Information

**EXAMPLE: BATRATM 3 A 4 ET**

- Series:** \_\_\_\_\_  
**Mounting:** \_\_\_\_\_  
 \* 0 = OEM  
 \* 1 = Panel Mount  
 2 = NEMA 4X Box (**BATRATM** behind clear cover)  
 3 = Explosion Proof Housing  
 5 = NEMA 4X Box (**BATRATM** outside opaque cover)  
 6 = Double Ended Explosion Proof Housing (consult factory)

- Power Supply:** \_\_\_\_\_  
 \* A = Battery (2 supplied)  
 B = External Power Supply (8.5 to 30 VDC)  
 C = Loop Powered with 4-20 mA Output  
 AC = Loop Powered with 4-20 mA Output and 2 Batteries

- Options (Multiple Options Available)** \_\_\_\_\_  
 S1 = Serial Setup Software  
 S2 = RS485/Modbus/Data Logger - Isolated  
 4 = 20 Point Linearization (10 point with S2 option)  
 D = Rate per Day, Hour or Minute  
 ET = Extended Temp.: -22°F to 158°F (-30°C to 70°C)  
 CE\*\* = CE Compliant  
 CSA\*\* = CSA Listed Explosion Proof (planned)  
 IS\*\* = UL Listed IS (planned)  
 TRX = NEMA7 Explosion Proof Reset Switch  
 RN = External Magnetic Reset  
 T = Third Conduit Entry in Ex-Proof Housing  
 H2 = 0.875" Hole for mounting styles 2 and 5  
 HF2 = 0.5" Female NPT Hub fitting for mounting styles 2 and 5  
 H3 = 1.125" Hole for mounting styles 2 and 5  
 HF3 = 0.75" Female NPT Hub fitting for mounting styles 2 and 5

- Accessories:**  
 BATPACK= External Batt. Pack with 2 C Size Batteries & 12" leads  
 BATC = Single Battery: Tadiran P/N TL2200/S 3.6V 7200mAh or equal  
 115-24 = 115 VAC to 24 VDC power supply  
 BSAC1 = RS232 Serial Adapter Cable

\* External battery pack supplied with models BATRTM0A & BATRTM1A  
 \*\* Contact factory for latest information

# BAT D/T MILLENNIUM

## LCD Dual Totalizer (Resettable & Non-Resettable)

### Features

- Magnetic Pickup Input, Contact Closure Input, DC Pulse Input (Optically Isolated)
- Displays 5 Digit Resettable Total  
8 Digit Grand Total
- 4-20mA Analog Output (optional)
- Powered From Internal Battery, External DC Supply or 4-20 mA Output Loop
- 20 Point Linearization (optional);  
10 Point Linearization with Data Logger option
- Isolated High/Low Flow Rate Alarm Output
- Nonvolatile Flash Memory of Setup Data
- Extended Battery Life



- RS232 Serial Communications (optional)
- RS485 Modbus Communications and Data Logger (optional)
- Setup Software Available for Easy Programming and Monitoring Using a PC

Flow Instruments  
FIELD INDICATORS

### Description

Featuring 5 digits of resettable total and 8 digits of grand total, the BAT D/T Millennium (BATDTM) is a battery powered indicator capable of accepting magnetic pickup, DC pulse and switch closure inputs from pulse producing flowmeters.

### Specifications

#### POWER:

##### BATTERY POWERED

Supplied with 2 C size Lithium battery pack.

##### EXTERNAL POWER INPUT

Voltage: 8.5 to 30 VDC

Current: Less than 5 mA

Supplied with 1 C size lithium battery for standby operation

Protection: Reverse Polarity Protection on DC Power Input

##### LOOP POWERED

Voltage: 8.5 to 30 VDC

Supplied with 1 or 2 C size lithium battery(ies) for standby operation

Protection: Reverse Polarity Protection on Current Loop

Loop Burden: 8.5V maximum

#### BATTERY LIFE EXPECTANCY:

Expected Years of Operation for BATRT-M of various powering options at equipment duty cycles

#### MODEL

#### RUN TIME

	Idle	2hrs/day	8hrs/day	24hrs/day
BATDT-M-A	10 yrs	10 yrs	10 yrs	9.1 yrs
BATDT-M-A-4	10 yrs	10 yrs	10 yrs	8.4 yrs
BATDT-M-B/C	10 yrs	10 yrs	10 yrs	10 yrs
<b>standby-operation</b>				
BATDT-M -B/C	Indefinite operation when externally powered			
External or loop power				

**NOTE:** Battery shelf life is rated at 10 years by manufacturer. Life expectancy based on rated battery capacity at 20°C. The above table is shown with pulse output inactive. Use of pulse output shortens battery life. Example: A pulse output of 0.06 sec. duration, once per second, would derate the battery life by 20%.

#### DISPLAY:

##### Resettable Total Display

5 Digits (99999), 0.35" High, Display updates once every two seconds

##### Grand Totalizer Display: (selectable decimal)

8 Digits (99999999), 0.2" High

Totalizer Descriptors: GAL, LIT, FT3, M3, "blank"

Warning Displays: Low battery warning

#### PULSE OUTPUT:

The pulse output advances with the least significant digit of the totalizer or decimal multiples thereof (see Pulse scale divider).

Type: Isolated photomos relay

Max. voltage (off state): 30 VDC

Current (on state): 100mA

Pulse Duration: Selectable 0.5, 0.25, 0.125, 0.0625 seconds

Pulse Scale divider (Pulscale): User selectable, +1, +10, +100 or OFF

NOTE: Select OFF for max. battery life.

#### ACCURACY:

0.01% Reading, ±1 count

Temperature Drift: 50 ppm/°C Worst Case

#### ENVIRONMENTAL:

##### OPERATING TEMPERATURE

-4°F (-20°C) to +158°F (70°C)

Extended Temp: -22°F (-30°C) to +158°F (70°C)

##### HUMIDITY

0 - 90% Noncondensing

#### MOUNTING STYLES:

0- Circuit Board-

OEM option (consult factory)

1- Panel Mount -

NEMA 4X Front

2- Wall Mount -

NEMA 4X Enclosure

(keypad mounted behind clear cover)

3- Explosion Proof -

Class I, Division I, Groups B, C & D

Class II, Division I, Groups E, F & G

5- Wall Mount -

NEMA 4X Enclosure

(keypad mounted on cover)

6- Double Ended Explosion Proof -

Class I, Division I, Groups B, C & D

Class II, Division I, Groups E, F & G

(contact factory for details)

**NOTE:** Meter mounting kits available for styles 2, 3 and 5

**INPUTS:**

**MAGNETIC PICKUP INPUT**

Frequency Range: 0 to 3500 Hz  
Trigger Sensitivity: 30 mV p-p (10 mV p-p on special order)  
Over Voltage Protected: ± 30 VDC

**OPTO-ISOLATED DC PULSE INPUT**

High (logic 1): 4-30 VDC  
Low (logic 0): Less Than 1 VDC  
Minimum Current: .5 mA  
Hysteresis: 0.4 VDC  
Frequency Range: 0 to 5 kHz  
Min. Pulse Width: 0.1 msec

**CONTACT CLOSURE INPUT (contact closure to common)**

Internal Pullup Resistor: 100 KΩ to +3.6 VDC  
High (logic 1): Open or 4-30 VDC  
Low (logic 0): Less Than .5 VDC  
Internal Switch Debounce Filter: 0 to 40 Hz

**NOTE:** Sustained contact closure will shorten battery life.

**RESET INPUT (contact closure to common)**

Internal Pullup Resistor: 100 KΩ to +3.6 VDC  
High (logic 1): Open or 4-30 VDC  
Low (logic 0): Less Than .5 VDC  
Minimum On : 25 msec

**NOTE:** Sustained contact closure will shorten battery life.

**K-FACTOR**

Range: 0.001 to 99999999  
Decimal Point Locations: XXXX.XXXX to XXXXXXXX

**20 Point Linearization Option (10 Point with Data Logger option)**

This feature allows the user to enter 20 different frequencies with 20 different corresponding K-Factors to linearize non linear signals.

**ANALOG OUTPUT OPTION:**

Type: 4-20 mA follows rate display, Two wire hookup  
Accuracy: 0.025% Full Scale at 20° C  
Temperature Drift:  
50 ppm/°C Typical  
Reverse Polarity Protected  
Update Rate: 8 times/second

**NOTE:** The BATRT-M uses the 4-20 mA loop power as its primary power source when this option is used. The battery is still required for standby battery operation.

**COMMUNICATIONS OPTION (S1):**

**RS232 SERIAL SETUP SOFTWARE OPTION:**

This option enables you to access a variety of process parameters through serial communications. PC compatible communications software is included with this option. With this software and a BATDTM Serial Adapter Cable (BSAC1) you will be able to setup the BATDTM through your PC.

**RS-485 MODBUS and DATA LOGGER OPTION (S2):**

The optional RS-485 card utilizes Modbus RTU protocol to access a variety of process parameters. The Data Logger stores the totalizer to flash memory once every 24 hours at the time you set.

**DATA STORAGE:**

Setup Information: Stored in flash memory  
Totalizer: Stored in battery backed RAM but can be saved to flash memory by operator for recall after battery change out.

**Typical Wiring:**

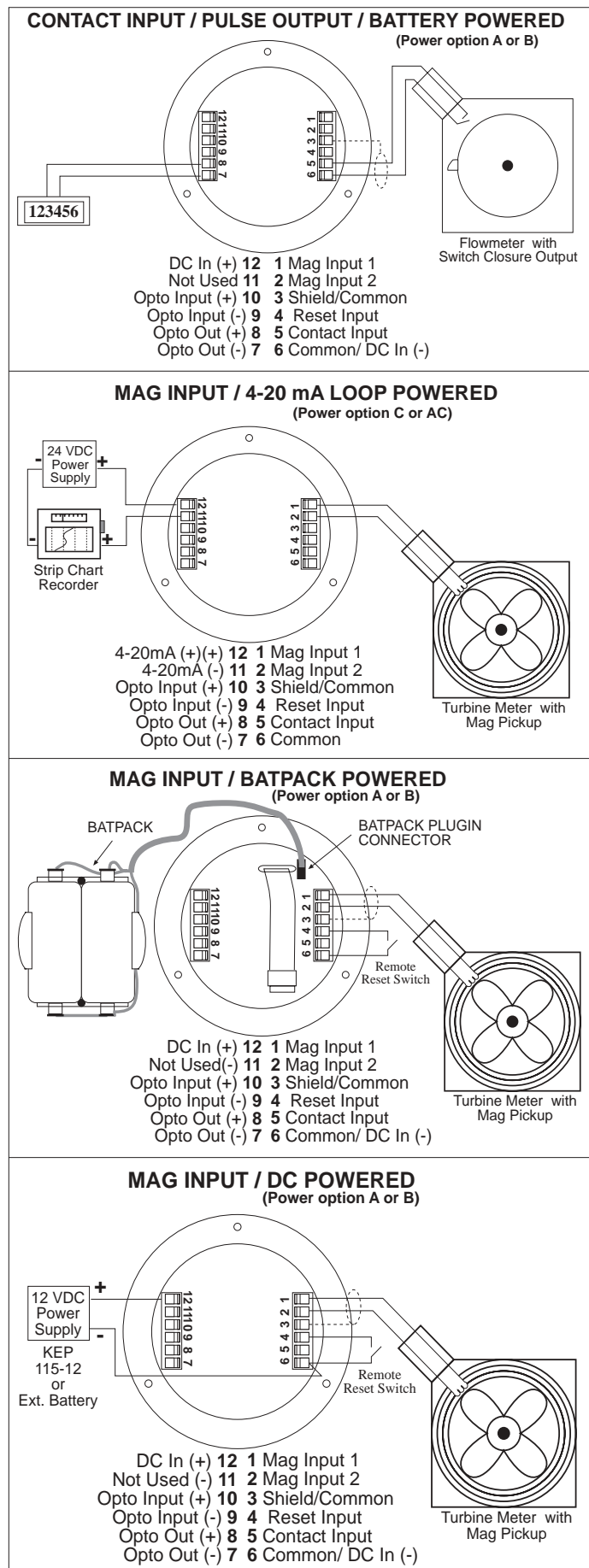

### BATPACK

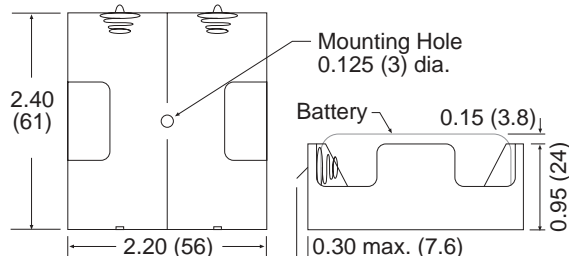

### BATDT-M-0

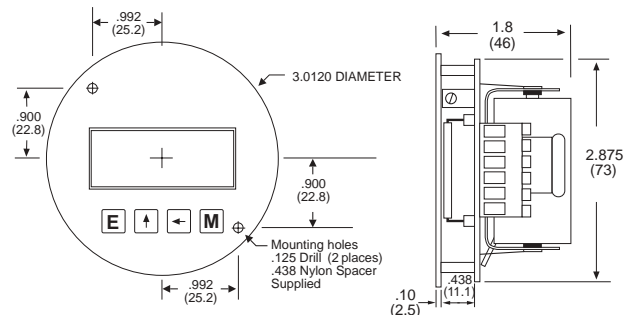

### BATDT-M-1

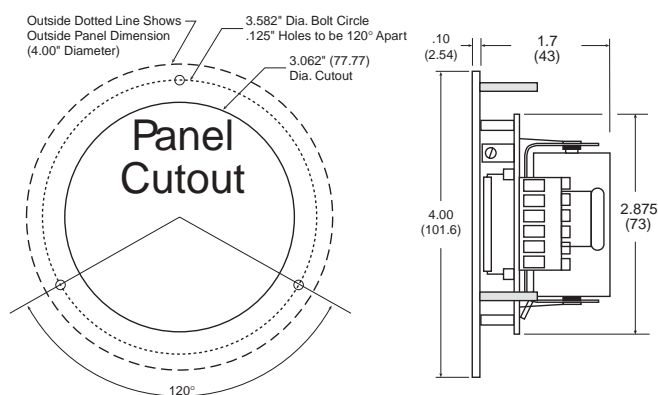

### BATDT-M-2

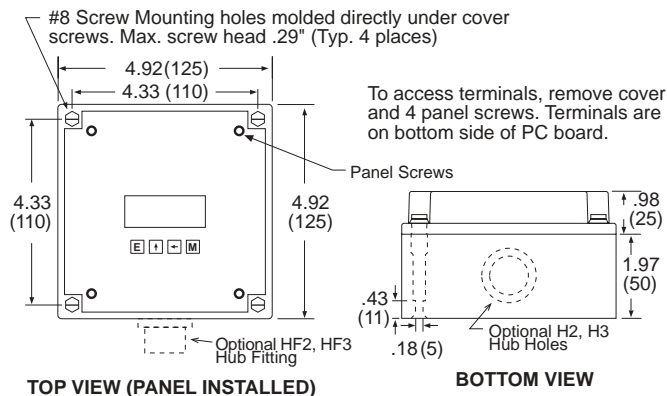

### BATDT-M-3

To access terminals, unscrew cover and loosen 2 panel screws. Terminals are on bottom side of PC board.

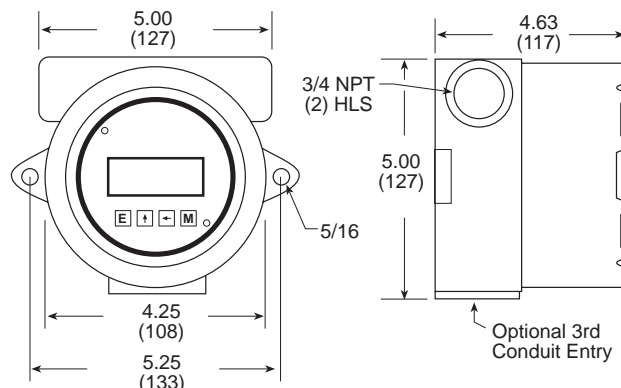

### BATDT-M-5

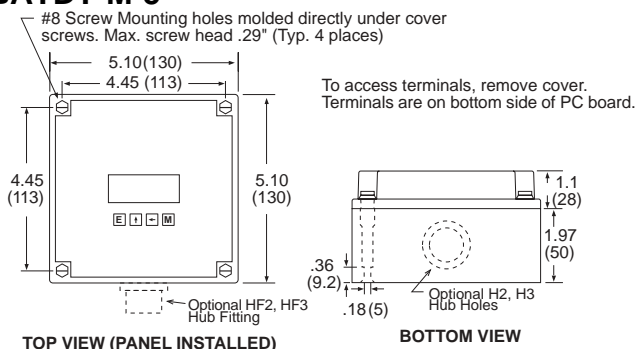

## Ordering Information

**EXAMPLE: BATDTM 3 A 4 ET**

- Series:** \_\_\_\_\_
- Mounting:** \_\_\_\_\_
- \* 0 = OEM
  - \* 1 = Panel Mount
  - 2 = NEMA 4X Box (BATDTM behind clear cover)
  - 3 = Explosion Proof Housing
  - 5 = NEMA 4X Box (BATDTM outside opaque cover)
  - 6 = Double Ended Explosion Proof Housing (consult factory)

- Power Supply:** \_\_\_\_\_
- \* A = Battery (2 supplied)
  - B = External Power Supply (8.5 to 30 VDC)
  - C = Loop Powered with 4-20 mA Output
  - AC = Loop Powered with 4-20 mA Output and 2 Batteries

- Options (Multiple Options Available)** \_\_\_\_\_
- S1 = Serial Setup Software
  - S2 = RS485/Modbus/Data Logger - Isolated
  - 4 = 20 Point Linearization (10 point with S2 option)
  - D = Rate per Day, Hour or Minute
  - ET = Extended Temp.: -22°F to 158°F (-30°C to 70°C)
  - CE\*\* = CE Compliant
  - CSA\*\* = CSA Listed Explosion Proof (planned)
  - IS\*\* = UL Listed IS (planned)
  - TRX = NEMA7 Explosion Proof Reset Switch
  - RN = External Magnetic Reset
  - T = Third Conduit Entry in Ex-Proof Housing
  - H2 = 0.875" Hole for mounting styles 2 and 5
  - HF2 = 0.5" Female NPT Hub fitting for mounting styles 2 and 5
  - H3 = 1.125" Hole for mounting styles 2 and 5
  - HF3 = 0.75" Female NPT Hub fitting for mounting styles 2 and 5

- Accessories:**
- BATPACK= External Batt. Pack with 2 C Size Batteries & 12" leads
  - BATC = Single Battery: Tadiran P/N TL2200/S 3.6V 7200mAh or equal
  - 115-24 = 115 VAC to 24 VDC power supply
  - BSAC1 = RS232 Serial Adapter Cable

\* External battery pack supplied with models BATRTM0A & BATRTM1A  
 \*\* Contact factory for latest information

# Ratometer / Totalizer Tutorial

**What is a Rate/Totalizer Indicator?** This is a general purpose instrument which conditions the electrical signal generated by the flowmeter and scales the resulting flow information into a flow rate and flow total display in the units of measure desired by the end user. Additional functionality such as alarms, analog output, pulse output, and serial communications may also be provided. Also see the section on flow computers. See the figure below for a typical system configuration.

**What capabilities should I look for to ensure compatibility with my type of flowmeter?** Rate/Totalizers are available to work with most flowmeter types and most common electrical signals produced by flowmeters. Begin by selecting an instrument(s) that will accept the signal provided by the flowmeter. In some cases an amplifier or signal conditioner may be necessary. Next decide whether linearization will be required within the Rate/Totalizer and how the calibration will be represented within the instrument. Also determine if the Rate/Totalizer can provide the correct power required to operate the flow sensor (if needed).

**What are basic areas of concern?** Most customers begin a selection by looking for the instrument that has the type of information display they prefer, that will work with the available power, and is available in a package which can be mounted in the desired location.

**What is an analog output and why is it used?** Flow rate information is usually sent from one system to another as a 4-20mA signal. Some instruments permit the user to select what item of information is to be sent on the analog output. The corresponding span is user programmable. Additional features include programmable damping and user selectable ranges.

**What is a pulse output and why is it used?** Flow total information is usually sent from one system to another as a pulse which represents a quantity of flow. The remote system may sum these pulses to compute the flow total. Attributes of a pulse output include provisions for user scaling of the amount of flow each pulse represents, and the width of the pulse. Specifications will usually list the electrical drive ratings for the pulse output.

**What is an alarm output and why is it used?** Relays are often used as controls to activate alarms. A alarm will usually include a provision for setting the alarm point. Additional features may include a programmable delay before the alarm will activate, a programmable alarm duration, and/or a programmable alarm hysteresis.

**What are remote inputs and how are they used?** Often there is a need to connect a remote switch near the operator for such purposes as remote reset, or remote print. Many Rate/Totalizers offer a variety of capabilities as remote inputs.

**What is serial communications and why is it used?** Serial communications is used to transmit information between two computers, or between a computer and a printer. There are several commonly used standard hardware interfaces. These include RS-232, RS-422, and RS-485. There are also a variety of communication protocols, or message formats, which are used. Some of these are unique to the equipment manufacturer, others are industry standards. See also the section on communication solutions.

**What is temperature compensation?** In some cases the temperature may also be used to estimate the fluid density from stored fluid properties. Many customers prefer to correct their flow readings to the equivalent mass or corrected volume at a desired reference temperature.

**What are other areas of concern?** Many areas where rate/totalizer indicators are installed are out of doors or are located in hazardous areas. Special purpose enclosures are available for many instruments to ensure that the equipment will be protected in these environments. A NEMA-4 rating is weather proof. A NEMA-7 rating is explosion proof.

## Typical Ratometer/Totalizer Application

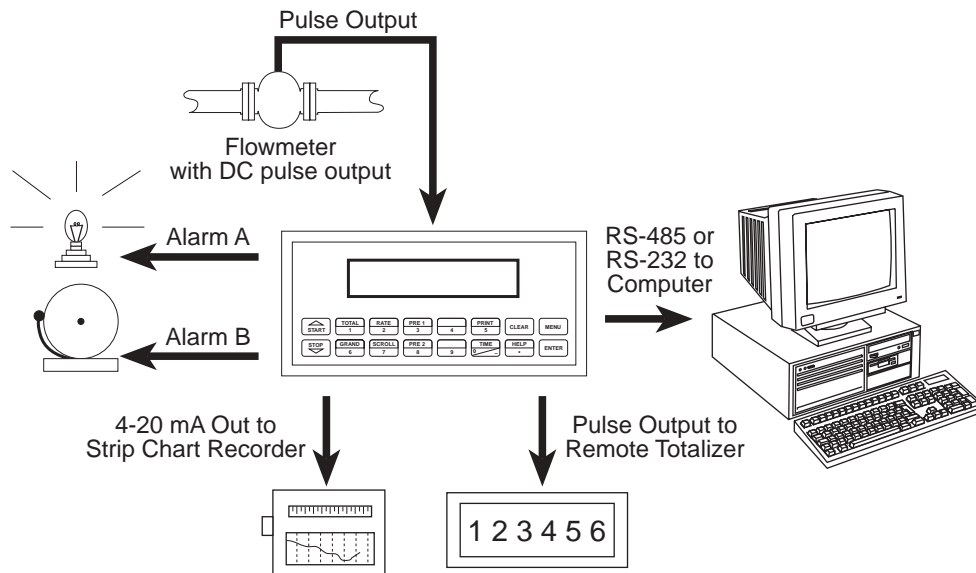



# 130K

## Battery Powered Totalizer with LCD Display

### Features

- Low price and high efficiency
- Large (8 mm) 8-digit LCD display,
- Optional backlighting
- NEMA4/IP65 Front Panel
- Screw terminals, RM 5 mm
- Lifetime of the battery approximately 8 years
- Locking of the reset key
- All versions for positive or negative counting edge



- Debounce filter function for counting with mechanical contacts.

### Specifications

- Power supply:** non-replaceable lithium battery (lifetime approximately 8 years at 20°C)
- Backlighting:** external electrical source 24 V DC +/-20 %, 50 mA
- Display:** LCD, 8 decades, 8 mm high characters
- Display range:** -9999999 to 99999999, with overflow display
- Reset:** manual and electrical
- Inputs:**
- A. Standard DC Input (max. 30 V DC)**
- Slow counting input:** max. 30 Hz NPN
- Fast counting input:** max. 12 kHz (PNP), 7 kHz (NPN)
- Switching level:**
- NPN: Low: 0 to 0.7 V, High: 3 to 30 V DC
- PNP: Low: 0 to 0.7 V, High: 4 to 30 V DC
- D. Reset Input**
- Minimum pulse time:**
- DC: 50 ms, high voltage: 16 ms
- Contact input DC:**
- NPN: Low: 0 to 0.7 V, High: 3 to 30 V DC

### E. Electrical reset key locking

- Contact input:** Open Collector NPN (switching at 0 V)
- Switching level:** NPN: Low: 0 to 0.7 V, High: 3 to 5 V DC
- Interference emissions:** EN 55011 Class B, EN 61000-6-2 EN 61010 Section 1 (only AC versions)
- Housing:** dark grey RAL 7021
- Operating temperature:** -10 to +55 °C
- Ambient temperature:** -10 to +60 °C
- Storage temperature:** -20 to +70 °C
- Protection:** NEMA4/IP65 front
- Weight:** approximately 50 g

### Dimensions

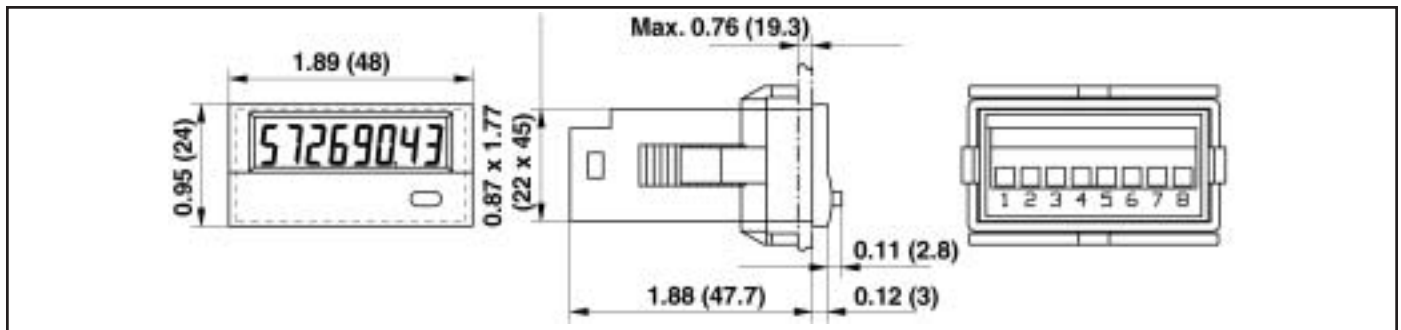

### Order Table

Type	Input type	Counting inputs							
		INP A				INP B			
130K.012.8x0	Count <sup>1)</sup>	0 ... 0,7 V DC	count	NPN	7 kHz	0 ... 0,7 V DC	count	NPN	30 Hz
130K.012.8x2		4 ... 30 V DC	count	PNP	12 kHz	0 ... 0,7 V DC	count	NPN	

X: 5 = no backlight      1): one-channel, adding or subtracting counting  
 X: 6 = with backlight

### Accessories:

N7 - Explosion proof housing (see accessories section)  
 E200 - Outdoor Enclosure (see accessories section)

# 525K, 529K & 530K

Rate and Total Indicators  
with Pulse or Analog Inputs

## Features

- 6 digit, LED display with very high luminosity  
0.315" (8mm) digit height
- DIN housing, 1.88"x.944" (48x24mm)
- Two button programming
- Connection with screw terminal
- IP65 NEMA 4X (front)
- DC Powered



## 525K

### Totalizer and Ratemeter

- Display range 0..999999 with leading zero blanking
- Overflow condition will be indicated by 1 Hz flashing of rate value and leading zeros of totalizer
- Count frequency up to 10kHz
- Indicates rate / sec or min (1/Tau)
- SET-key resets the counter to zero (can be disabled in the setup)
- key to switch rate / total display
- 1 count input
- 1 reset input
- Separate multiplying factors totalizer / ratemeter (0.00001...99.9999)
- Operating mode: Rate meter: 1/Tau (average value at higher frequencies)

Order #: 525K.2

#### Accessories:

E200 - Outdoor Enclosure (see Accessories section)

## 529K & 530K

### Analog Displays

- Display range -19999..0..99999 with leading zero blanking
- Resolution 14 bit
- 5 digit rate display; 6 digit total display (530K)
- 4 different resolutions (0..20mA; 4..20mA; 0..10V or 2..10V)
- Scaling factor for displayed value
- Automatic storage of maximum and minimum value (can be disabled in setup)
- Input to activate storing of displayed value

Listing: UL listed (file#: E128604)

#### Order #:

529K.2 = Rate Display Only

530K.2 = Rate and Total Display

#### Accessories:

E200 - Outdoor Enclosure (see Accessories section)

#### Electrical characteristics:

- Supply Voltage: 10 to 30 VDC (50 mA)
- Data retention: EEPROM (1 million cycles or 10 years)
- Noise immunity acc. to EN 50081-2; EN55011 class B; EN 50082-2
- Ambient temperature: 14°F to 122°F (-10°C to +50°C)
- Input sensitivity: Low: 0 to 1 VDC High: 4 to 30 VDC (525K)
- Input resistance: 10 k ohm (525K)
- Polarity of inputs: programmable for all inputs in common
- Optocoupler: Max 30VDC, 10 mA, 1V drop @ 10 mA

Panel Cutout: 0.876" x 1.78" (22.3 x 45.2mm)  
or 0.99" x 1.97" (25 x 50mm) with adaptor provided

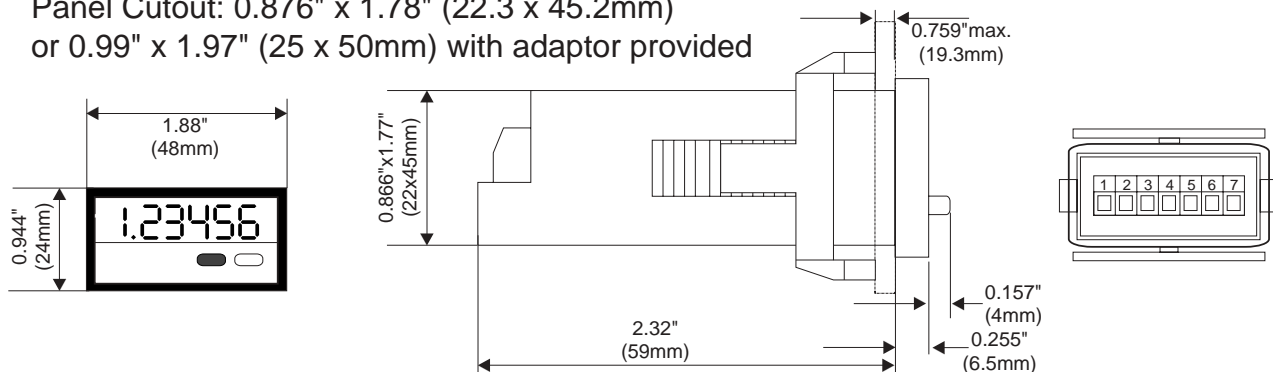

# INTELLECT-69

## Ratometer / Totalizer From Analog Inputs

### Features

- High/Low Scaling From Front Panel
- 2 Set Points Assignable To Rate or Total
- Display Rate, Integrated Total and Peak & Valley
- 0-5V, 0-10V, 1-5V, 4-20mA or 0-20mA Analog Input
- NEMA 4X/IP 65 Front Panel
- +24V Output Power For Peripherals
- RS422/232 Serial Communications (optional)
- 4-20mA Output (optional)
- Square Root Extraction (optional)
- Rate Per Day Feature (optional)

### Description:

Featuring 6 digits of bright, 7-segment LED displays, the Intellect-69 is an integrating totalizer/ratometer which accepts analog signal inputs. The unit can be field programmed to accept 4-20mA, 0-20mA, 0-5V, 0-10V or 1-5V signals. An optional Square Law input is available for inputs that require square root extraction. A 4-20mA output option is available to control strip recorders or to transmit linear signal other peripherals. Two assignable set points are standard. The high and low scaling settings are programmable from the front panel. By pressing the "view" button, the unit will display: integrated total, rate, peak or valley. Press the "lock" key once to freeze the display. RS422 or RS232 serial communications are available options for data communication with a host computer.

### Specifications:

**Display:** 6 digit, .55" high, 7 segment, red orange, LED.

**Input Power:** 110, 220 VAC  $\pm$  15% or 12 to 24VDC.

Current: max. 300mA DC or 10.0VA (10W) at rated AC voltage.

**Output Power:** (AC powered units only) + 24VDC @ 50mA regulated  $\pm$ 5% (100 mA available on request)

### Temperature:

Operating: +41°F (5°C) to +130°F (+54°C).

Storage: -40°F (-40°C) to +200°F (93°C).

**Humidity:** 0-90% Noncondensing

**Memory:** EEPROM stores data for ten years if power is lost.

### Reset:

Front Panel: resets displayed values and control outputs.

Remote: 4-30VDC positive edge, resets totalizer and control outputs.

### Input:

Standard: Linear 4-20mA, 0-20mA, 0-5V, 0-10V or 1-5V selectable from the front panel.

Optional: Square Law 4-20mA, 0-20mA, 0-5V, 0-10V or 1-5V is available for inputs that require square root extraction.

**Input Impedance:** Current: 100 $\Omega$ ; Voltage: 115K $\Omega$

**Overvoltage Protection:** 50 V

**Overcurrent Protection:** 50 mA

**Resolution:** 14.5 Bits



**Listing:** CE Compliant, CSA Listed (File No. LR91109), NRTL/C pending

**Calibration:** The unit does all of the calibrations internally. There are no potentiometers to adjust and the unit never needs to be removed from the case.

### Control Outputs:

Standard: Open collector sinks 250mA from 30VDC when active.

Optional: 2 each Form C SPDT 5 Amp @ 120/240 VAC or 28 VDC.

**Set Points:** The two control set points can be set at any number from 0 to 59999. The set point outputs can be assigned to rate or total. The unit comes standard with two open collector control outputs. Two 5 Amp, Form C relays are optional. The outputs are programmable from .01 to 599.99 sec or latched until reset when assigned to the total and a hysteresis (alarm range) when assigned to the rate.

**Rate Display:** Updates 2 times per second, Accurate to 4.5 digits. Set "low" greater than "high" for inverted display (LINEAR ONLY). A user programmable low cutoff inhibits indications at low flow rates.

**Totalizer:** Integrates from the rate reading and accumulates up to 6 digits of total count. A totalizer divider allows the total to be divided by 1, 10, 100 or 1000. This feature is especially useful for users who deal with high total volumes.

**Analog Output:** The unit can be ordered with an optional 4-20mA output which is proportional to the instantaneous rate. (The normalizing averaging factor does not affect the analog output) The high and low settings are programmable from the front panel. Set "low" greater than "high" for inverted output. A sinking driver generates a corresponding linear current through the external devices. The output updates with each update of the rate. Accuracy is  $\pm$ .25% FS worst case. Compliance voltage must be 3 to 30 VDC non inductive. (The unit can provide the DC source as long as the drop across the devices being driven does not exceed 21V).

**Programming:** Decimal points, Scaling from 0 to 59999 units per selected time base, set points, input type, security lock code, and assigning outputs are all programmable from the front panel.

**Housing:** Standard 1/8 DIN, high impact ABS plastic case (NEMA 4X/IP65 front panel).

**Shipping Weight:** 2 lbs.

**Accuracy:**

RANGE	% FS ERROR (worst case)	% FS ERROR (typical)
-------	----------------------------	-------------------------

0-20 mA	0.1%	.05%
4-20 mA	0.1%	.05%
0-10 VDC	0.2%	0.1%
0-5 VDC	.25%	.15%
1-5 VDC	.25%	.15%

Square Law: (above 5% of bottom range) 0.1%  
(5V inputs .4%) Worst case over complete range: 2%

**Temperature Stability:** Will not drift more than 20 parts per million per °C from 5°C to 54°C

**WIRING:**

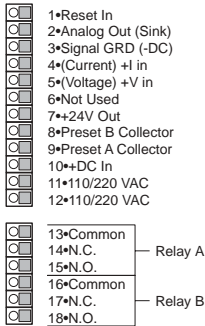

**Dimensions:**

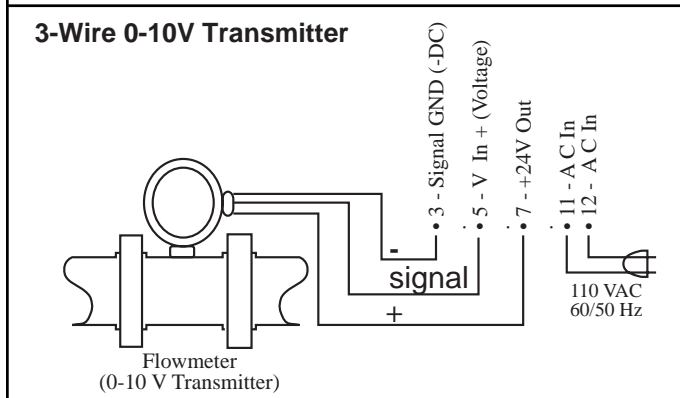
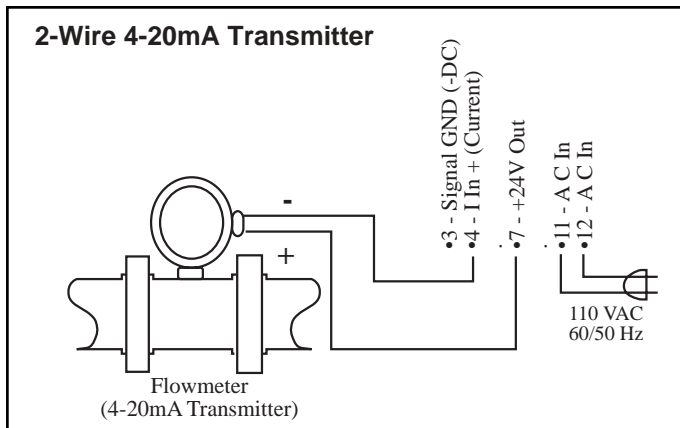
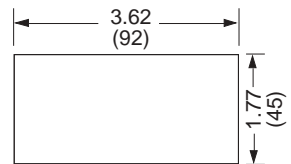
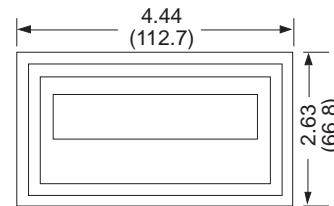
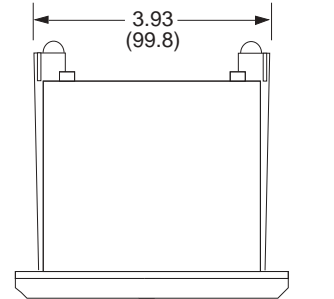
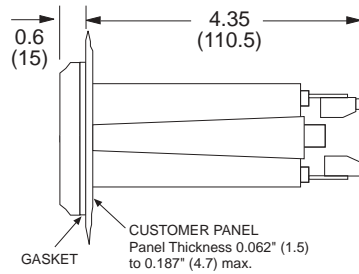

**Ordering Information**

**Example:** INT69RT A L 1 A C1

**Series:**  
 INT69RT= Ratemeter / Totalizer  
 INT69R= Ratemeter Only  
 INT69T= Totalizer Only

**Operating Voltage:**  
 A= 110 VAC ± 15% or 12 to 24 VDC  
 B= 220 VAC ± 15% or 12 to 24 VDC

**Inputs:**  
 L= Linear (standard)  
 S= Square Law (optional)

**Control outputs:**  
 1= 2 - Open Collector Outputs (standard)  
 2= 2 - 5 Amp Form C Relays (optional)

**Options (Multiple Options Available)**  
 A= Analog Output (4-20 mA)  
 D= Rate per Day, Hour or Minute  
 C1= RS 232 communications  
 C2= RS 422 communications

**Accessories**

Separate non keyboard panel order #34235  
 Separate keyboard panel - order #34234  
 NEMA 4X wall mount enclosure available, see NEMA-1/8DIN  
 XHV 7/4 Explosion Proof Housing available, see XHV7/4  
 Serial printer available, see P1000, P295  
 Ethernet Port Server available, see IEPS  
 RS-422/485 to RS-232 Communication Adaptor available, see CA285

# MRT (MINITROL)

## Low Cost, Pulse Input Totalizer/Ratemeter

### Features

- Separate Scaling Factors For A & B Inputs
- Display Rate & Total
- Pulse Input - 10 kHz Max.
- RS422/RS232 Serial Communication (optional)
- Modbus RTU RS422/RS485/RS232 (optional)
- NEMA 4X / IP65 Front Panel
- Separate Add/Subtract Simultaneous Inputs
- Quadrature and Up/Down Direction Control Inputs (optional)
- 30mV Magnetic Pickup Inputs (optional)

### Application:

Any rate, total or blending application where 2 preset alarms and scaling are required.

### Description:

The MINITROL is a 6 digit totalizer / ratemeter with two level, 5 digit preset alarm control of total or rate. Inputs A & B have separate scaling K-factors. The totalizer can be programmed for "A" subtract "B", "A" add "B" or A & B as separate totalizers, with display and control of the "net" total and rate of "A". The MINITROL is also available in 4 other versions. MC2: a two preset totalizer with scaling, MR2: a high/low alarm ratemeter with scaling; The "MC": a totalizing counter only, and the "MR": a rate meter display only. If only one input is required, the unit will display the total and rate from that one channel. The MINITROL can accept up to 10,000 pulses per second. It has a 5 digit floating decimal scale factor allowing total readout in true engineering units and rate per second, minute or hour.

Input "A" simultaneously drives a ratemeter which can be programmed to display the basic frequency (rate per second) or factored to show rate per minute or rate per hour. Simply push the "VIEW" button to see either total or rate without losing a count. Two separate 5 A relay contacts can be set to operate at either rate or total presets in a latch or auto-recycle mode with output timing from 0.1 to 99.9 seconds.

Two control outputs can be assigned to either the totalizer or ratemeter and can automatically recycle at the batch or stay latched until reset.

Up to 99 units can communicate to a host computer on a single RS232 or RS422 loop.

When two inputs are received (A & B), the unit can either add or subtract the two inputs or display the two inputs as separate totalizers.



- 4-20mA or 0-20mA Analog Output (optional)
- CSA Listed

### Specifications:

**Display:** 6 digit, 0.55" High LED

**Input Power:**

110 VAC  $\pm$  15% or 12 to 15 VDC

220 VAC  $\pm$  15% or 12 to 15 VDC

24VAC  $\pm$  15% or 12 to 15 VDC

**Current:** 250 mA DC max. or 6.5 VA AC

**Output Power:** (AC powered units only)

+12 VDC @ 50 mA, unregulated -10 + 50%

**Temperature:**

Operating:

+32°F (0°C) to +130 F (+54°C)

Storage:

-40 F (-40°C) to +200°F (93°C)

**Humidity:** 0-90% Noncondensing

**Memory:** EEPROM stores data for 10 years if power is lost.

**Inputs:**

3: High Impedance DC pulse input 4-30 VDC (high), Open or 0-1 VDC (low), 10 K $\Omega$  imp. 10 kHz max. speed. Accepts simultaneous inputs.

3M: Mag. Input, Input A only, accepts 30mV input (50 V max. P/P) signals 10 K $\Omega$  imp. 5 kHz max. (Input B, 4-30V)

3MB: Mag. Input, Inputs A & B, accepts 30mV input (50 V max. P/P) signals 10 K $\Omega$  imp. 5 kHz max.

5: 4-30 V Count pulses on Input A, 4-30 V Direction Control input (level) on Input B.

5M: 30 mV Count pulses on Input A (50 V max. P/P) 4-30 V Direction Control input (level) on Input B.

9: Quadrature, accepts 4-30 V pulses with 90° phase shift for direction detection.

9MB: Quadrature, accepts 30 mV (50 V max. P/P) pulses with 90° phase shift for direction detection.

**Approvals:** CSA File# LR91109-7, CE Compliant

**Reset:**

Front Panel:

Resets displayed value and control output

Remote:

4-30 VDC negative edge resets Totalizer "A" and control output

**Control Outputs:**

Relays:

2 each N.O. Relay; 5 Amps 120/240 VAC or 28 VDC. (N.C. relay contacts and NPN transistor output available with solder jumpers. Transistor output is internally pulled up to 10 VDC through relay coil, sinks from 10 VDC to .5 V @ 100 mA)

Analog Output:

An optional 4-20mA (0-20mA) output is available for the Minitrol series. The output can be programmed to track rate or total. This feature is available by adding suffix A to the part number. Connections are via a 2 terminal pluggable screw connector. Programming is accomplished by using the front panel in conjunction with rear dip switches.

Accuracy:  $\pm 0.25\%$  FS worst case.

Compliance Voltage: 3 to 30 VDC non inductive.

**Scaling Factor (K-Factor):** In the standard unit, a user programmable K-Factor is used to convert the input pulses to engineering units. The 5 digit K-Factor dividers, with decimal keyed into any position, allow easy direct entry of any K-Factor from 0.0001 to 99999. Separate factors may be entered for the 2 separate input channels.

**Presets:** Two control outputs are provided. To set relay values, press "menu" button until "Relay" appears on the display, the A and B outputs can be assigned to the ratemeter (high/low), one preset for rate and one for total, or two presets on the A and B totalizers. A 5 digit value can be entered for both presets and the decimal point location is the same as the counter. The outputs can be set to energize from 0.1 to 99.9 seconds or latch (0.0). If a value other than 0.0 is entered, the totalizers will auto reset at the preset. In the A-B or A+B versions, the relays will be assigned to either net total or A rate.

**Lockout:** Unauthorized front panel changes can be prevented by entering a user selected 5 digit code in the "LOC" mode. The front panel can be completely locked out or the presets can remain accessible.

**Ratemeter:** Accuracy: 0.01% FS ( $\pm 1$  display digit).

The rate display updates once per second. The rate meter can be programmed to accept almost any number of pulses per unit of measurement, sample from 2 to 24 seconds maximum, and auto-range up to 5 digits of significant information. In the "RPS" mode, the ratemeter displays in units per second, and in the "scale" mode, units per hour or per minute. The unit will display the rate of the A Input only.

**Totalizer:** The two 6-digit totalizers can count at 10 kHz max. Each can have a 5-digit dividing scale factor. The totalizer advances on the positive edge of each pulse. Count up or down modes available, as are quadrature inputs from encoders for position or flow measurement. The unit can be programmed to view the net value of "A+B" or "A-B", or A and B as separate totalizers.

**RS232/RS422 with KEP Protocol:**

If the serial interface option is supplied, multiple units can be linked together. (The terminal addressing the unit must be capable of driving all loads in the loop.) Unit status and new set points can be communicated by serial communication. Mode changes, however, must always be made on the front panel.

Data is received and transmitted over standard EIA RS232 or RS422 levels. Unit number, baud rate and parity are entered in the "Program Setting" set up mode and remain in memory even if power is off.

**RS232/RS422/RS485 with Modbus RTU Protocol:**

The serial port can be used for serial printing or also for data acquisition. The unit can assign addresses up to 247 units (The terminal addressing the unit must be capable of driving all loads in the loop.) The unit can communicate with a master device through a Modbus-RTU protocol. The data given for each parameter is in IEEE float format comprising of 2 words. The unit can be connected in a network.

Device ID: 01-247

Baud Rates: 300, 600, 1200, 2400, 4800, 9600

Parity: None, Odd, Even

Protocol: Modbus RTU (Half Duplex)

## Mounting:

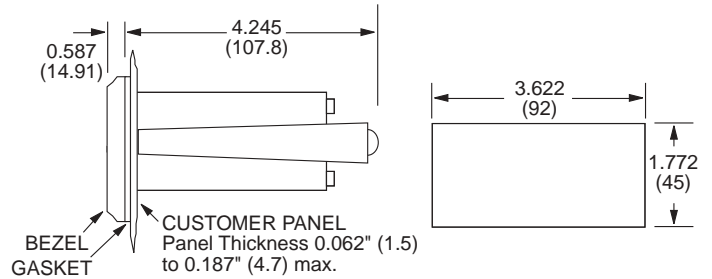
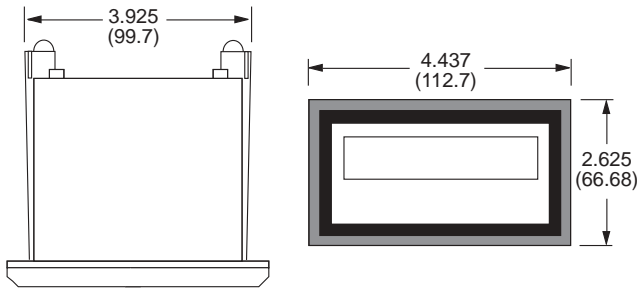

## Termination:

- |                       |        |              |                  |
|-----------------------|--------|--------------|------------------|
| ○ 1- COMMON           | RELAYS | ○ 13- V+     | ANALOG<br>OUTPUT |
| ○ 2- N.O.(N.C./NPN)   |        | ○ 14- I SINK |                  |
| ○ 3- COMMON           | RELAYS |              |                  |
| ○ 4- N.O.(N.C./NPN)   |        |              |                  |
| ○ 5- A INPUT          |        |              |                  |
| ○ 6- B INPUT          |        |              |                  |
| ○ 7- 12VDC OUT/+DC IN |        |              |                  |
| ○ 8- -DC (GROUND)     |        |              |                  |
| ○ 9- RESET INPUT      |        |              |                  |
| ○ 10- NOT USED        |        |              |                  |
| ○ 11- A.C. INPUT      |        |              |                  |
| ○ 12- A.C. INPUT      |        |              |                  |

## Ordering Information

**Example:** MRT A 3 1

Series: \_\_\_\_\_

MRT= 6 digits, ratemeter/totalizer with presets and scaling.  
 MC2= 6 digits, totalizer only with presets and scaling.  
 MR2= 5 digits, rate only with presets and scaling.

Operating Voltage: \_\_\_\_\_

A= 110 VAC ± 15% or 12 to 15 VDC  
 B= 220 VAC ± 15% or 12 to 15 VDC  
 C= 24 VAC ± 15% or 12 to 15 VDC

Count Inputs: \_\_\_\_\_

3 = Standard, 4-30 VDC simultaneous inputs.  
 3M = Mag. Input, Input A only, 30mV input (Input B, 4-30V)  
 3MB = Mag. Input, Inputs A & B, 30mV input  
 5 = 4-30 V pulses on Input A, 4-30 V Direction Control input on Input B.  
 5M = 30 mV pulses on Input A, 4-30 V Direction Control input on Input B  
 9 = Quadrature, accepts 4-30 V pulses  
 9MB = Quadrature, accepts 30 mV pulses (A & B)

Options \_\_\_\_\_

- 1= RS232 Communications
- 2= RS422 Communications
- 3= Modbus RTU RS232
- 4= Modbus RTU RS422/RS485
- A= Analog Output (4-20/0-20 mA)

**NOTE:** RS232/RS422/RS485 & Analog Output options can not be combined

### Accessories

- Separate non keyboard panel order #34235
- Separate keyboard panel - order #34234
- NEMA4 wall mount enclosure available, see NEMAtrol
- Explosion proof enclosure available, see XHV
- Serial printer available, see P1000, P295
- Ethernet Port Server available, see IEPS
- RS-422/485 to RS-232 Communication Adaptor available, see CA285
- Modbus DDE/OPC Server available, see KEPServer

Flow Instruments  
RATEMETERS/TOTALIZERS

# MINITROL-S

## Totalizer/Ratemeter with Separate Scaling of Rate/Total

### Features

- Separate Scaling Factors For Rate & Total
- Display Rate & Total
- 30mV Magnetic Pickup Inputs (optional)
- Count Inhibit Input for Meter Proving
- Security Lockout
- RS422/RS232 Serial Communication (optional)
- NEMA 4X / IP65 Front Panel
- 4-20mA or 0-20mA Analog Output (optional)
- CSA Listed

### DESCRIPTION:

The totalizer and ratemeter display each have their own 5 digit dividing scale factor. The two 5 AMP preset relay outputs can be programmed by the user to apply to the "A" total counter or the "A" ratemeter. The user can view the rate, total and grand total. The B relay can be used to create a scaled pulse output. Magnetic pickup input, analog output and RS232 communication options are available.

### SPECIFICATIONS:

**DISPLAY:** 6 digit, 0.55" High LED

#### INPUT POWER:

110 VAC  $\pm$  15% or 12 to 15 VDC

220 VAC  $\pm$  15% or 12 to 15 VDC

24 VAC  $\pm$  15% or 12 to 15 VDC

**CURRENT:** 250 mA DC max. or 6.5 VA (6.5W) AC

**OUTPUT POWER** (AC powered units only)

+12 VDC @ 50 mA, unregulated -10 + 50%

#### TEMPERATURE:

Operating: +32°F (0°C) to +130 F (+54°C)

Storage: -40 F (-40°C) to +200°F (93°C)

**MEMORY:** EEPROM stores data for 10 years if power is lost.

#### INPUTS:

3: High Impedance DC pulse input 4-30 VDC (high), Open or 0-1 VDC (low), 10 K $\Omega$  imp. 10 kHz max. speed.

3M: Mag. Input, Rate/total input only, accepts 30mV input (50 V max. P/P) signals 10 K $\Omega$  imp. 5 kHz max. (Inhibit input, 4-30V)

**NOTE:** The Mag. input has filtering as follows: 30mV trigger level up to 300Hz, 0.25 V trigger level at 5KHz

#### RESET:

Front Panel: Resets displayed total value and control output.

Remote: 4-30 VDC negative edge resets the A total and relay control output.

**NOTE:** The remote reset does not reset the grand total.

**LISTING:** CSA (File No. LR91109), CE Compliant, NRTL/C pending

#### K FACTOR/SCALING:

The K-Factors are used to convert the input pulses to engineering units. The 5 digit K-Factor dividers, with decimal keyed into any position, allow easy direct entry of any K-Factor from 0.0001 to 99999. Separate factors may be entered for rate and total permitting rate display to be in a different unit of measure than the total.



### CONTROL OUTPUTS:

#### Relays:

2 each N.O. Relay; 5 Amps, 120/240 VAC or 28 VDC. (N.C. relay contacts and NPN transistor output available via solder jumpers.

#### Analog Output:

An optional 4-20mA (0-20mA) output is available for the Minitrol series. The output can be programmed to track rate or total. This feature is available by adding suffix A to the part number. Connections are via a 2 terminal pluggable screw connector. Programming is accomplished by using the front panel in conjunction with rear dip switches.

Accuracy:  $\pm$  0.25% FS

Compliance Voltage: 3 to 30 VDC non inductive.

### RS232/RS422

If the serial interface option is supplied, multiple units can be linked together. (The terminal addressing the unit must be capable of driving all loads in the loop.) Unit status and new set points can be communicated by serial communication. Mode changes, however, must always be made on the front panel.

Data is received and transmitted over standard EIA RS232 or RS422 levels. Unit number, baud rate and parity are entered in the "Program Setting" set up mode and remain in memory even if power is off.

### RS232/RS422/RS485 with Modbus RTU Protocol:

The serial port can be used for serial printing or also for data acquisition. The unit can assign addresses up to 247 units (The terminal addressing the unit must be capable of driving all loads in the loop.) The unit can communicate with a master device through a Modbus-RTU protocol. The data given for each parameter is in IEEE float format comprising of 2 words. The unit can be connected in a network.

Device ID: 01-247

Baud Rates: 300, 600, 1200, 2400, 4800, 9600

Parity: None, Odd, Even

Protocol: Modbus RTU (Half Duplex)

### PRESETS:

Two control outputs are provided. To set relay A or B's functionality, press "menu" button until "Relay" appears on the display, the A and B outputs can be assigned to the rate alarm (high/low), or for total/grand total. A 5 digit value can be entered for both presets A and B. The decimal point location is the same as the counter. The outputs can be set to energize from 0.1 to 99.9 seconds or latch (0.0). If a value other than 0.0 is entered, the corresponding totalizer will auto reset at the preset. This may be used to create a relay scaled pulse output.



**LOCKOUT:**

Unauthorized front panel changes can be prevented by entering a user selected 5 digit code, in the "LOC" mode. The front panel can be completely locked out or the presets can remain accessible.

**RATEMETER**

Accurate to 4 1/2 digits (±1 display digit). The rate meter can be programmed to:

- accept almost any number of pulses per unit of measurement
- determine rate for slow pulsing signals (up to 24 sec).
- auto-range up to 5 digits of significant information.

The display can be programmed to read in units per Second (SEC), Minute (MIN), Hour (HOUR), or Day (DAY).

**TOTALIZER:**

The two 6-digit totalizers can count at 10kHz speed. They share a 5-digit dividing scale factor. The totalizer advances on the positive edge of each pulse.

**TYPICAL SENSOR HOOKUP:**

**Dimensions:**

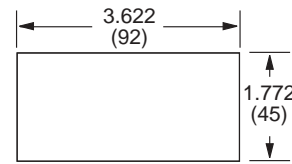
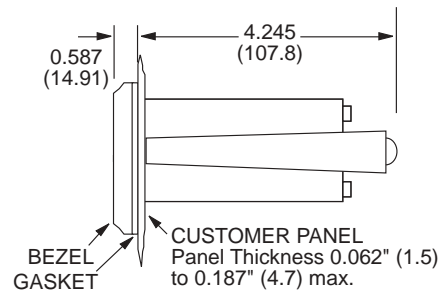
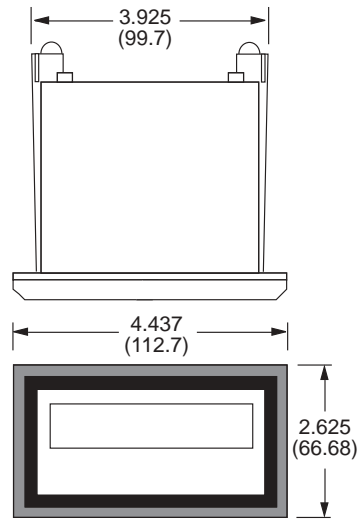

Flow Instruments  
RATEMETERS/TOTALIZERS

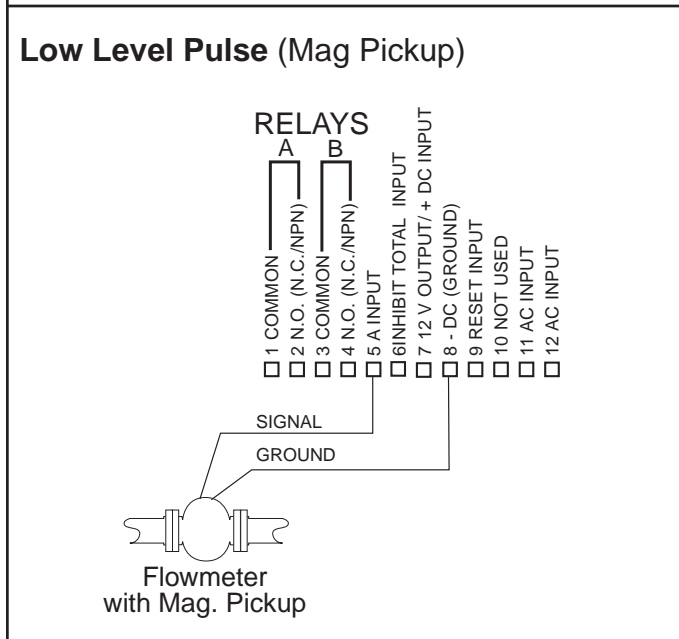
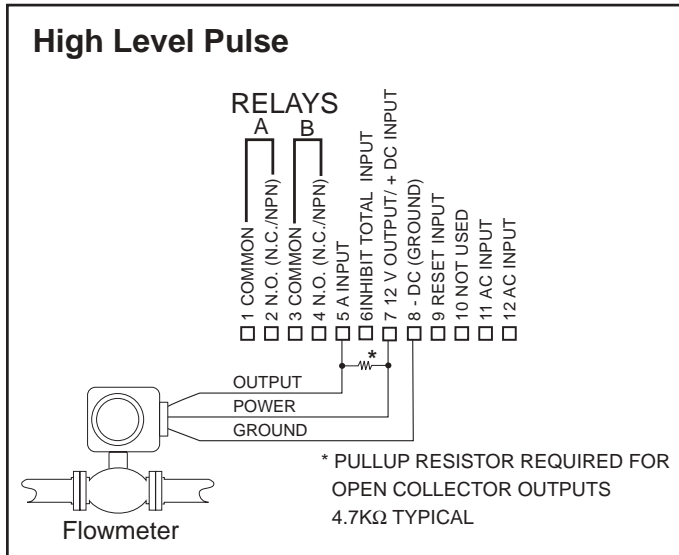

**Ordering Information**

**Example:** MRTS A 3 1

**Series:** MRTS=6 digit counter / 5 digit ratemeter with presets and scaling.

**Operating Voltage:** A= 110 VAC ± 15% or 12 to 15 VDC  
B= 220 VAC ± 15% or 12 to 15 VDC  
C= 24 VAC ± 15% or 12 to 15 VDC

**Count Inputs:** 3 = Standard, 4-30 VDC simultaneous inputs.  
3M = Mag. Input, rate/total input only, 30mV input (Inhibit input, 4-30V)

**Options**  
1= RS232 Communications  
2= RS422 Communications  
3= Modbus RTU RS232  
4= Modbus RTU RS422/RS485  
A= Analog Output (4-20/0-20 mA)

**NOTE:** RS232/RS422/RS485 & Analog Output options can not be combined

**Accessories**  
Separate non keyboard panel order #34235  
Separate keyboard panel - order #34234  
NEMA4 wall mount enclosure available, see NEMAtr0l  
Explosion proof enclosure available, see XHV  
Serial printer available, see P1000, P295  
Ethernet Port Server available, see IEPS  
RS-422/485 to RS-232 Communication Adaptor available, see CA285  
Modbus DDE/OPC Server available, see KEPServer

# MINITROL-PW

## Totalizer/Ratemeter for Paddle or Pelton Wheel Turbine Flowmeters

### Features

- Display Rate & Total  
Flowrate Display =  $\frac{\text{Input Frequency} + \text{Offset B}}{\text{Factor A}}$
- 30mV Magnetic Pickup Inputs (optional)
- RS422/RS232 Serial Communication (optional)
- NEMA 4X / IP65 Front Panel
- 4-20mA or 0-20mA Analog Output (optional)



### DESCRIPTION:

The Minitrol-PW is a single input counter/ratemeter intended for use with low flow paddle or pelton wheel turbine flowmeters. Two scale factors are used to describe the flowmeter calibration characteristics. The two 5 AMP preset relay outputs can be programmed by the user to apply to the "A" total counter or the "A" ratemeter. The user can view the rate, total and grand total.

### SPECIFICATIONS:

**Electrical Specifications:** See MINItrol-S

**Dimensions:** See MINItrol-S

### K FACTOR/SCALING

The K-Factor is used to convert the input pulses to engineering units. The two 5 digit scale factors, with decimal keyed into any position, allow easy direct entry of any scaling factor from 0.0001 to 99999. Factor A is used to enter the linearized K-Factor and Factor B is used to enter the offset frequency.

### LOW FLOW CUTOFF:

A low flow cutoff is provided to inhibit operation in low flow out of range regions.

### RATEMETER

Accurate to 4 1/2 digits ( $\pm 1$  display digit). The rate meter can be programmed to accept almost any number of pulses per unit of measurement and auto-range up to 5 digits of significant information. The display can be programmed to read in units per Second (SEC), Minute (MIN), Hour (Hour), or Day (DAY).

### COUNTER

The two 6-digit totalizers can count at 10kHz speed. They share a 5-digit dividing scale factor. The totalizer performs as follows:

### If Freq. In > Cutoff

$$\text{Total increment} = \frac{\text{Freq. Offset} \cdot \Delta \text{ Time} + \text{Pulses In}}{\text{K Factor A} \quad \text{K Factor A}}$$

$$\text{Rate} = \frac{(\text{Frequin} + \text{Freq offset}) \cdot \text{time base}}{\text{K Factor A}}$$

Time base: Sec = 1, Min = 60, Hour = 3600, Day = 86400

### If Freq. In < Cutoff

$$\begin{aligned} \text{Total Increment} &= 0 \\ \text{Rate} &= 0 \end{aligned}$$

Total B (grand total) increments with Total A.

### THEORY OF OPERATION

Low flow, Pelton Wheel turbine flowmeters have a transfer characteristic which can best be represented by the following equation for frequencies above the minimum usable flowrate for the device:

$$\text{frequency} = \left( \frac{K_{\text{linearized}} \cdot \text{GPM}}{60} \right) - \text{Offset Frequency}$$

Where:  $K_{\text{linearized}}$ , and offset frequency are scaling constants determined during flow sensor calibration.

This transfer characteristic applies within the meter manufacturers published range. Below some minimum flow meter output frequency, the flow rate should be considered as 0 and the totalization inhibited. This is called the "cutoff" frequency.

### Ordering Information

**Example:** MRTPW A 3 1

**Series:** \_\_\_\_\_

MRTPW= 6 digit counter / 5 digit ratemeter with presets and scaling.

**Operating Voltage:** \_\_\_\_\_

A= 110 VAC  $\pm$  15% or 12 to 15 VDC

B= 220 VAC  $\pm$  15% or 12 to 15 VDC

C= 24 VAC  $\pm$  15% or 12 to 15 VDC

**Count Inputs:** \_\_\_\_\_

3 = Standard, 4-30 VDC simultaneous inputs.

3M = Mag. Input, rate/total input only, 30mV input (Inhibit input, 4-30V)

**Options** \_\_\_\_\_

1= RS232 Communications

2= RS422 Communications

A= Analog Output (4-20/0-20 mA)

**NOTE:** RS232/RS422 & Analog Output options can not be combined

### Accessories

Separate non keyboard panel order #34235

Separate keyboard panel - order #34234

NEMA4 wall mount enclosure available, see NEMAtrol

Explosion proof enclosure available, see XHV

Serial printer available, see P1000, P295

Ethernet Port Server available, see IEPS

RS-422/485 to RS-232 Communication Adaptor available, see CA285

Flow Instruments  
RATEMETERS/TOTALIZERS

# DRT (Dual rate/totalizer)

## 2 Separate Rate/Total Displays with Combination Function

### Features

- Displays A,B,&C Rate & A,B,&C Total
- Separate Scaling Factors For A & B Inputs
- "C" Displays A+B, A-B, A÷B, & A÷A+B
- RS422/RS232 Serial Communication
- Modbus RTU RS422/RS485/RS232
- Pulse Input - 10 kHz Max.
- Security Lockout
- NEMA 4X / IP65 Front Panel
- 30mV Magnetic Pickup Inputs

### DESCRIPTION:

The DRT (Dual Rate Totalizer) is a dual 5 digit Ratemeter 6 digit Totalizer in a 1/8 DIN package. User selects 1 of 6 displays to show A, B or C rate and A, B or C total. Inputs A and B have separate scaling to read in engineering units.

A 4-20mA (0-20mA) output of the C rate or total is optional.

The user can press the VIEW button to see 6 separate items total A, total B, total C, rate A, rate B, rate C. Negative values are displayed with a negative symbol (- 12345). For the C value, the user can choose from the following combination of A&B inputs: TOTAL; with a choice of A+B or A-B; RATIO with choice of A÷B(x100) to show percent of A to B quantity or A÷[A+B(x100)] to show percent of A to total quantity.

Two independent presets are standard. User selects whether output A is activated by total or rate value of input A or selected C. Output B can be activated by total or rate value of input B or selected C. Outputs activated by A or B total can be set to latch or autorecycle with an adjustable output duration from 00.1 to 99.9 sec. For rate, ratio, or C total outputs pull in when value is equal or above the preset and drop out when value is below the preset minus the selected 0 to 999 hysteresis.

### SPECIFICATIONS:

#### DISPLAY:

6 digit, 0.55" High LED

#### INPUT POWER:

110 VAC ± 15% or 12 to 15 VDC

220 VAC ± 15% or 12 to 15 VDC

24VAC ± 15% or 12 to 15 VDC

#### CURRENT:

250 mA DC max. or 6.5 VA (6.5W) AC

#### OUTPUT POWER: (AC powered units only)

+12 VDC @ 50 mA, unregulated -10 + 50%

#### TEMPERATURE:

Operating: +32°F (0°C) to +130 F (+54°C)

Storage: -40 F (-40°C) to +200°F (93°C)

**HUMIDITY:** 0-90% Noncondensing



- 4-20mA or 0-20mA Analog Output
- CSA Listed

### MEMORY:

EEPROM stores data for 10 years if power is lost.

### INPUTS:

3: High Impedance DC pulse input 4-30 VDC (high), Open or 0-1 VDC (low), 10 KΩ imp. 10 kHz max. speed. Accepts simultaneous inputs.

3M: Mag. Input, Input A only, accepts 30mV input (50 V max. P/P) signals 10 KΩ imp. 5 kHz max. (Input B, 4-30V)

3MB: Mag. Input, Inputs A & B, accepts 30mV input (50 V max. P/P) signals 10 KΩ imp. 5 kHz max.

### RESET:

Front Panel: Resets displayed value and control output

Remote: 4-30 VDC negative edge resets all counters, "A" counter or "B" counter (user selectable).

### K FACTOR/SCALING

The DRT has two separate K-Factors that are used to convert the input pulses to engineering units. The 5 digit K-Factor dividers, with decimal keyed into any position, allow easy direct entry of any K-Factor from 0.0001 to 99999. Separate factors may be entered for the 2 separate input channels.

### CONTROL OUTPUTS:

#### Relays:

2 each N.O. Relay; 5 Amps 120/240 VAC or 28 VDC.

(N.C. relay contacts and NPN transistor output available with solder jumpers. Transistor output is internally pulled up to 10 VDC through relay coil, sinks from 10 VDC to .5 V @ 100 mA)

#### Analog Output:

An optional 4-20mA (0-20mA) output is available for the DRT. The output can be programmed to track rate or total of the C display. This feature is available by adding suffix A to the part number. Connections are via a 2 terminal pluggable screw connector. Programming is accomplished by using the front panel in conjunction with rear dip switches.

Accuracy: 50uA worst case.

Compliance Voltage: 3 to 30 VDC non inductive.

**Approvals:** CSA File# LR91109-7, CE Compliant

**PRESETS**

Two control outputs are provided. To set relay values, press "menu" button until "Relay" appears on the display, the A and B outputs can be assigned to the A, B or C displays. A 5 digit value can be entered for both presets and the decimal point location is the same as the counter. The outputs can be set to energize from 0.1 to 99.9 seconds or latch (0.0). If a value other than 0.0 is entered, the counters will auto reset at the preset (for A&B counters).

**LOCKOUT**

Unauthorized front panel changes can be prevented by entering a user selected 5 digit code. The front panel can be completely locked out or the presets can remain accessible.

**RATEMETER**

Accurate to 4 1/2 digits ( $\pm 1$  display digit). The ratemeter uses 1/tau with 8 digit math, can sample from 2 to 24 seconds maximum, and auto-range up to 5 digits of significant information. In the "RPS" mode, the ratemeter displays in units per second, and in the "scale" mode, units per hour or per minute. The unit will display the rate of the A&B Inputs.

**TOTALIZER**

The two 5-digit totalizers can count at 10Khz speed. Each has a separate 5-digit dividing scale factor. The totalizers advance on the positive edge of each pulse. Besides being able to step

through the total and rate values of A & B inputs, the user can see a selected combination of total and rate of A+B, A-B, (A+B)X100 (percent of A to B), A÷(A+B)X100 (percent of A to total). The unit can be programmed to view the Total/Rate value of "A+B" & "A-B", or "A÷B" & "A÷(A+B)".

**RS232/RS422 with KEP Protocol:**

If the serial interface option is supplied, multiple units can be linked together. (The terminal addressing the unit must be capable of driving all loads in the loop.) Unit status and new set points can be communicated by serial communication. Mode changes, however, must always be made on the front panel. Data is received and transmitted over standard EIA RS232 or RS422 levels. Unit number, baud rate and parity are entered in the "Program Setting" set up mode and remain in memory even if power is off.

**RS232/RS422/RS485 with Modbus RTU Protocol:**

The serial port can be used for serial printing or also for data acquisition. The unit can address up to 247 units (The terminal addressing the unit must be capable of driving all loads in the loop.) The unit can communicate with a master device through a Modbus-RTU protocol. The data given for each parameter is in IEEE float format comprising of 2 words. The unit can be connected in a network.

- Device ID: 01-247
- Baud Rates: 300, 600, 1200, 2400, 4800, 9600
- Parity: None, Odd, Even
- Protocol: Modbus RTU (Half Duplex)

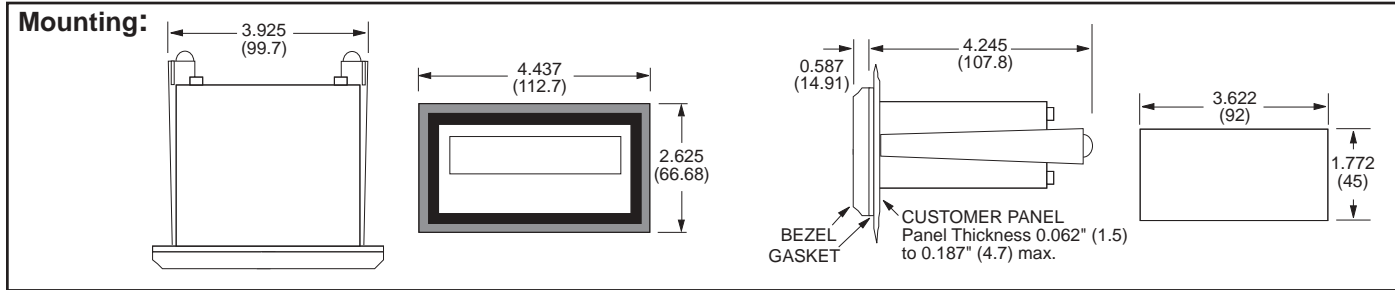

**Terminals:**

- 1- COMMON
  - 2- N.O.(N.C./NPN)
  - 3- COMMON
  - 4- N.O.(N.C./NPN)
  - 5- A INPUT
  - 6- B INPUT
  - 7- 12VDC OUT/+DC IN
  - 8- -DC (GROUND)
  - 9- RESET INPUT
  - 10- NOT USED
  - 11- A.C. INPUT
  - 12- A.C. INPUT
  - 13- V+
  - 14- I SINK
- RELAYS A B
- ANALOG OUTPUT
- |   |        |        |
|---|--------|--------|
|   | OFF    | ON     |
| 1 | RUN    | CAL.   |
| 2 | 4-20mA | 0-20mA |
| 3 | RATE   | COUNT  |
| 4 | RUN    | SET    |
- SWITCH
- NO

**Ordering Information**

**Example:** DRT A 3 1

**Series:** DRT= 6 digit counter / 5 digit ratemeter with presets and scaling.

**Operating Voltage:**

- A= 110 VAC  $\pm$  15% or 12 to 15 VDC
- B= 220 VAC  $\pm$  15% or 12 to 15 VDC
- C= 24 VAC  $\pm$  15% or 12 to 15 VDC

**Count Inputs:**

- 3 = Standard, 4-30 VDC simultaneous inputs.
- 3M = Mag. Input, Input A only, 30mV input (Input B, 4-30V)
- 3MB = Mag. Input, Inputs A & B, 30mV input

**Options:** (Multiple Options Not Available)

- A= Analog Output (4-20/0-20 mA)
- 1= RS232 Communications
- 2= RS422 Communications
- 3= Modbus RTU RS232
- 4= Modbus RTU RS422/RS485

**NOTE:** RS232/RS422/RS485 & Analog Output options can not be combined

**Accessories**

- Separate non keyboard panel order #34235
- Separate keyboard panel - order #34234
- NEMA4 wall mount enclosure available, see NEMA4tr0l
- Explosion proof enclosure available, see XHV
- Serial printer available, see P1000, P295
- Ethernet Port Server available, see IEPS
- RS-422/485 to RS-232 Communication Adaptor available, see CA285
- Modbus DDE/OPC Server available, see KEPserver

# SUPERtrol-I LE

## Economical Flow Totalizer, Ratemeter and Batcher

### Features

- EZ Setup Feature Speeds Instrument Setup
- Setup Diskette
- Advanced Batching Features, Including Quick Batching Sequence
- Menu Selectable Hardware Features
- Two Line LCD or VFD Display
- NEW! - 0-20mA or 4-20mA Analog Output
- NEW! - Attractive Wall Mount Enclosure
- Isolated Pulse Output Standard
- RS-232 Port Standard, RS-485 Optional
- Advanced Printing Capabilities
- Data Logging & Modem Remote Metering Support
- DIN Enclosure with Two Piece Connectors
- DDE Server & HMI Software Available

### Description:

The SUPERtrol-I LE Flow Computer satisfies the instrument requirements for a variety of pulse producing flowmeter types in liquid applications.

The alphanumeric display shows measured and calculated parameters in easy to understand format. Single key direct access to measurements and display scrolling is supported. An EZ Setup feature rapidly guides the user through the basic setup.

The SUPERtrol-I LE can be programmed for rate/total indication or batching. The various pulse inputs and outputs can be "soft" assigned to meet a variety of common application needs. The user "soft selects" the usage of each feature while configuring the instrument. A 0-20mA or 4-20mA analog output is standard.

The user can assign the standard RS-232 Serial Port for data logging, transaction printing, or for connection to a modem for remote meter reading. An optional RS-485 serial port using Modbus RTU protocol is available.

A Service or Test mode is provided to assist the user during start-up system check out by monitoring inputs and exercising outputs. The system setup can also be printed.

### Specifications:

#### Environmental

Operating Temperature: 0°C to +50°C  
Storage Temperature: -40°C to +85 C  
Humidity : 0-95% Non-condensing  
Materials: U.L. approved

**Listing:** UL/C-UL Listed (File No. E192404), CE Compliant

#### Display

Type: 2 lines of 20 characters  
Types: Backlit LCD and VFD ordering options  
Character Size: 0.3" nominal  
User programmable label descriptors and units of measure

#### Keypad

Keypad Type: Membrane Keypad  
Keypad Rating: Sealed to Nema 4  
Number of keys: 16



### Enclosure

Depth behind panel: 6.5" including mating connector  
Type: DIN  
Materials: Plastic, UL94V-0, Flame retardant  
Bezel: Textured per matt finish

### Power Input

The factory equipped power option is internally fused. An internal line to line filter capacitor and MOV are provided for added transient suppression.

110 VAC Power Option: 85 to 127 Vrms, 50/60 Hz  
220 VAC Power Option: 170 to 276 Vrms, 50/60 Hz

DC Power Option:  
12 VDC (10 to 14 VDC)  
24 VDC (14 to 28 VDC)

### Flow Inputs:

#### Pulse Inputs:

Number of Flow Inputs: one (single or quadrature)  
Input Impedance: 10 K $\Omega$  nominal  
Pullup Resistance: 10 K $\Omega$  to 5 VDC (menu selectable)  
Pull Down Resistance: 10 K $\Omega$  to common  
Trigger Level: (menu selectable)

#### High Level Input

Logic On: 3 to 30 VDC  
Logic Off: 0 to 1 VDC

#### Low Level Input (mag pickup)

Sensitivity:  
10 mV or 100 mV

#### Minimum Count Speed:

User selectable (as low as 1 pulse/99 seconds)

#### Maximum Count Speed:

Selectable: 40 Hz, 3000 Hz or 20kHz

#### Overvoltage Protection: 50 VDC

Linearization: Average K or 16 Point linearization with separate forward and reverse tables

### Control Inputs

Number of Inputs: 3  
Switch Inputs are menu selectable for Start, Stop, Reset, Lock, Inhibit, Alarm Acknowledge, Print or Not Used.

#### Control Input Specifications

Input Scan Rate: 10 scans per second

Logic 1: 4 - 30 VDC

Logic 0: 0 - 0.8 VDC

Input Impedance: 100 K $\Omega$

#### Control Activation:

Positive Edge or Pos. Level based on product definition for switch usage.

### Excitation Voltage

Menu Selectable: 5, 12 or 24 VDC @ 100 mA (fault protected)

### Data Logging

The data logger captures print list information to internal storage for approximately 1000 transactions. This information can be used for later uploading or printing. Storage format is selectable for Comma-Carriage Return or Printer formats.

### Batching Features

Quick batching sequence, single or dual stage batching, slow fill, auto-batch restart and batch overrun compensation.

**Serial Communication**

The serial port can be used for printing, datalogging, modem connection and communication with a computer.  
RS-232:

- Device ID: 01-99
- Baud Rates: 300, 600, 1200, 2400, 4800, 9600, 19200
- Parity: None, Odd, Even
- Handshaking: None, Software, Hardware
- Print Setup: Configurable print list and formatting.
- Print Out: Custom form length, print headers, print list.
- Print Initialization: Print on end of batch, key depression, interval, time of day or remote request.

RS-485: (optional 2nd COM port)

- Device ID: 01-247
- Baud Rates: 1200, 2400, 4800, 9600, 19200
- Parity: None, Odd, Even
- Protocol: Modbus RTU (Half Duplex)

**Relay Outputs**

The relay outputs are menu assignable to (Individually for each relay) Low Rate Alarm, Hi Rate Alarm, Prewarn Alarm, Preset Alarm or General purpose warning (security).  
Number of relays: 2 (4 optional)  
Contact Style: Form C contacts  
Contact Ratings: 5 amp, 240 VAC or 30 VDC

**Isolated Pulse output**

The isolated pulse output is assigned to Uncompensated Volume Total.  
Pulse Output Form: Photomos Relay  
Maximum On Current: 25 mA  
Maximum Off Voltage: 30 VDC  
Saturation Voltage: 1.0 VDC  
Maximum Off Current: 0.1 mA  
Pulse Duration: 10 mSec or 100mSec (user selectable)  
Pulse output buffer: 256  
Fault Protection  
Reverse polarity: Shunt Diode

**Fig. 1: Standard Dimensions**

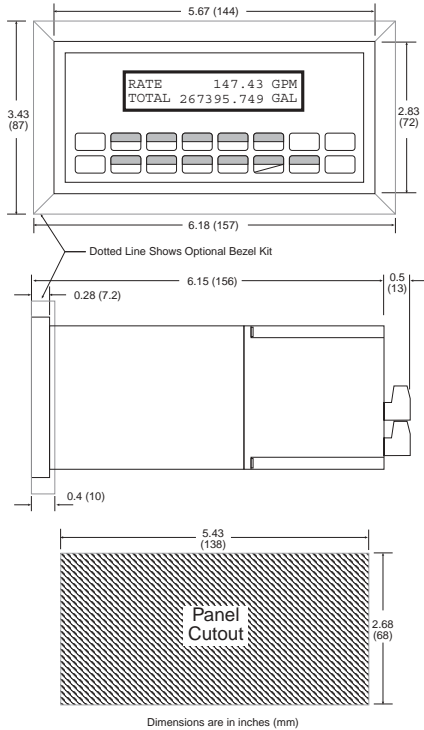

**Fig. 2: Wall Mount ("W" mounting option) Dimensions**

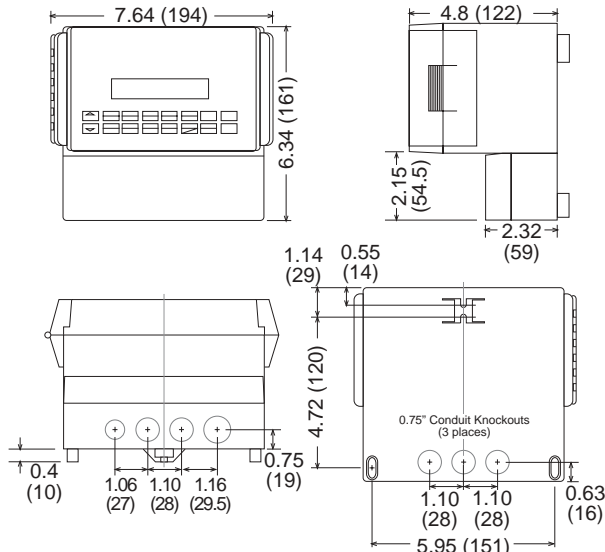

**Terminal Designations**

1	DC OUTPUT	2	FLOW IN 1	3	FLOW IN 2	4	COMMON	5	DO NOT USE	6	DO NOT USE	7	DO NOT USE	8	DO NOT USE	9	CNTR IN 1	10	CNTR IN 2	11	CNTR IN 3	12	COMMON	13	PULSE OUTPUT +	14	PULSE OUTPUT -	15	ANALOG OUTPUT +	16	ANALOG OUTPUT -	17	NC	18	COM RLY1	19	NO	20	NC	21	COM RLY2	22	NO	23	AC LINE DC +	24	AC LINE DC -
---	-----------	---	-----------	---	-----------	---	--------	---	------------	---	------------	---	------------	---	------------	---	-----------	----	-----------	----	-----------	----	--------	----	----------------	----	----------------	----	-----------------	----	-----------------	----	----	----	----------	----	----	----	----	----	----------	----	----	----	--------------	----	--------------

SEE USER MANUAL

**Ordering Information**

Example ST1LE L 1 A 0 P E T

**Series:** ST1LE = SUPERTrol-I LE

**Display Type:**  
 L = LCD  
 V = VFD

**Input Type:**  
 1 = 110 VAC  
 2 = 220 VAC  
 3 = 12 VDC (10 to 14 VDC)  
 4 = 24 VDC (14 to 28 VDC)

**Relays:**  
 A = 2 SPDT Relays  
 B = 4 SPDT Relays

**Network Card:**  
 0 = None (STD)  
 2 = RS485/Modbus (optional 2nd COM port)

**Mounting:**  
 P = Panel Mount (see Fig. 1)  
 N = NEMA 4 Wall Mount (see NEMAtr01ST4X)  
 W = NEMA 12/13 Wall Mount w/ Clear Cover (see Fig. 2)  
 E = Explosion Proof (No Button Access) (see XHVD 7/4)  
 X = Explosion Proof (with Button Access) (see XTROL 7/4)

**Options:**  
 TB = RS485 Terminal Block for Panel Mount Enclosure  
 ET = Extended Temperature (consult factory)  
 -4°F to 131°F (-20°C to 55°C)  
 IM = Internal Modem  
 M = Modem Power Option

**Accessories:**

KEPS-KEP1-32 = KEP RS232 for SUPERTrol 1, SUPERTrol 1LE, SUPERTrol 2 and LEVELtrol 2 • 32 Bit DDE Server  
 Modem Available, see MPP-2400 and MPP-2400N (requires M option)  
 Serial printer available, see P1000, P295  
 Ethernet Port Server available, see IEPS  
 RS-422/485 to RS-232 Communication Adaptor available, see CA285  
 Remote metering and data collection software available, see TROLlink

# KEPTROL R/T

## TOTALIZER / RATEMETER

### Features

- Pulse or Analog Input Ordering Options
- Display Total, Rate or Grand Total
- Two Alarm Outputs, User Selectable for Total, Rate or Grand Total
- Pulse Input to 20 kHz Count Frequency
- K-Factor Programmable to 8 Places
- Password Protection
- Two Way RS232/422/ Communications Option
- NEMA 4X/IP 65 Front Panel
- Scalable Analog Output of Rate or Total (optional)
- 16 Point Linearization Option



### Description:

Featuring 8 digits of bright, .55", alphanumeric display, the pulse input version of the KEPTROL R/T can accept up to 20,000 pulses per second. The analog input version accepts inputs, such as 4 to 20mA or 1 to 5V. The standard KEPTROL R/T has two separate, 8 digit, floating decimal, "K" factors to convert the inputs to meaningful total and rate data. An optional 16 point K-factor can linearize flow from meter outputs. The user, with the push of a button, can toggle back and forth to view the total, the rate of flow and the grand total count. Two control outputs can be assigned independently by the user to activate at preset limit of total, rate or grand total for .1 to 9.9 seconds or until reset.

A scaled pulse output is also provided by an open collector driver. Since the output frequency is user selectable at 10, 200, 2K or 20K Hz, the unit can transmit the total data to remote electromechanical or electronic totalizers as well as computers, programmable controllers or other monitor equipment.

An optional analog output allows the user to select low and high settings to control strip chart recorders or other peripherals. Up to 15 units can be connected to optional RS232 or RS422 communications port to set control points or access data.

### Specifications:

**Display:** 8 Digit, .55" High, 15 Segment, Red Orange, LED.

**Input Power** (Internally Fused)

A: 110 VAC  $\pm 15\%$  or 12 to 27 VDC

B: 220 VAC  $\pm 15\%$  or 12 to 27 VDC

**Current:** Maximum 250mA DC or 3.2VA (3.2W) at rated AC voltage.

**Output Power:** (On AC powered units only)  
+12 VDC at 100mA. Separate Isolated 12 VDC at 100mA to allow +12 VDC or +24 VDC regulated  $\pm 5\%$  worst case. DC Outputs are supplied with resettable fuses.

**Memory:** EEPROM stores all program and total data for minimum of 10 years if power is lost.

### Pulse Inputs:

3A: Standard, High impedance pulse input. Open or 0 to 1 VDC (low), 3 to 30 VDC (high), 10K Ohm impedance, 20 kHz max. input speed (min. on/off 25  $\mu$ sec.).

3B: Same as 3A but has 4.7K Ohm input pull up resistors to +5 VDC on input for pulsing with contact to ground or NPN open collector transistor.

### Analog Inputs:

The current loop or voltage input is converted to a highly linear 0 to 10 kHz frequency. This frequency can then be scaled by the 8 digit K-Factors to total or display rate in separate engineering units.

Accuracy over full temperature range:

Zero error: +0.175% full scale max.

Overall error: +0.5% full scale max.

5A/7A: 4-20mA, 250 Ohm impedance

5B/7B: 0-20mA, 250 Ohm impedance

5C/7C: 1-5 VDC, 15K Ohm impedance

5D/7D: 0-5 VDC, 15K Ohm impedance

5E/7E: 0-10 VDC, 15K Ohm impedance

6A: 4-20 mA, Square Law, 250 Ohm impedance

### Reset:

Front push button: "Clear" resets displayed number and control output. Remote: 3 to 30 VDC positive edge resets the totalizer and control output. Impedance: 10K to ground  
Minimum pulse: 5 msec.

### Temperature:

Operating: +32°F (0°C) to +130°F (+54°C).

Storage: -40°F (-40°C) to +200°F (+93°C).

ET: Extended Temperature -40° to 158°F (-40° to 70° C)

**ET not available with analog inputs or outputs**

**Humidity:** 0-90% Noncondensing

**Listing:** CE Compliant

**Totalizer:** Each of the total and grand total counters have 8 digits. In the set-up mode choose "R0" (reset to zero) for adding operation or "SP" (set to preset) for subtracting operation. While viewing the total, the display can be made to flash the grand total by pressing "ENT". Activating "CLR" while the grand total is flashing, resets the grand total counter.

**Ratemeter:** Accurate to 5 1/2 digits ( $\pm 1$  display digit). The rate meter can be programmed to accept almost any number of pulses per unit of measurement for pulse rate as low as one pulse every 24 seconds, and autorange up to 6 digits of significant information. The rate meter with a "K" factor of 1 displays the rate of pulses per second. Simply dial in the proper "K" factor to display in minutes, hours or other units of measurement. Press the "C" button while the unit is displaying the total to display the rate as indicated by "R" displayed on the left side of the display.

**Password Lockout:** Two stage lockout is available for allowing change of presets only or total lockout of front panel parameter changes. Unauthorized front panel changes can be prevented by entering a user selected four digit password code.

**Factored Output:** The KEPtrol R/T gives one pulse out for each factored total count. Open collector sinks 30 VDC maximum to 1 volt maximum at 100mA maximum. Output speed is user selectable (see table below). An internal buffer holds up to 10,000 pulses for output at the selected frequency before "DATA LOST" flashes, indicating output pulses were lost. If factored rate exceeds 7 digits "RFF..." flashes. This alarm indicates that the maximum displayed rate has been exceeded.

Speed(HZ)	10	200	2000	20000
Min. on/off (msec)	47.5	2.0	0.2	0.013

**Control Outputs:** (Each of two outputs)

1. NPN Transistor Version: (Optional)

Open collector sinks max. 250mA from 30 VDC when active.

2. SPDT Relay Version:

10A 120/240 VAC or 28 VDC (Standard).

**Analog Output:** Digital input or analog input (except Square Law) versions can be ordered with an analog output of the rate or total reading. User keys in the low and high settings at set-up.

**Current Outputs:**

A sinking driver generates a corresponding linear current through the external devices, updating with each update of the rate display. Accuracy is  $\pm 5\%$  worst case. Compliance voltage must be 3 to 24 VDC, non inductive. (The KEPtrol R/T can provide the DC source as long as the drop across all devices being driven does not exceed 21 V).

**Voltage Outputs:**

When the voltage out option is ordered, a controlled voltage output is located at terminal 3 and referenced to pin 12 (ground). Accuracy is .1% @ 20°C ( max. drift .01%/C° ).

**Preset Alarms:** Two control alarms are provided on the KEPtrol R/T. The preset numbers can be made to flash without interrupting the control function by pressing "A" (Preset A) or "B" (Preset B). Press "ENT" to return to rate or total display. Change the preset by clearing the flashing preset number and keying in a new setpoint number before pressing the "ENT" button. (Count pulses may be lost if the preset is changed while pulses are coming in.) In the "Relay Set-Up" the user selects either or both preset outputs to be activated by the total, grand total or rate. If selected for total or grand total the outputs can be set to activate at the preset total for 0.1 to 9.9 seconds or latch (0.0 setting) until reset. If selected for rate control, the rate will be compared with the preset at each display update and the output activated if the rate is equal to or greater than the preset. The output drops out again only if the rate drops below the preset. If the rate goes out of scale the display will show all "F" and the output will remain in the state prior to going out of scale.

**K-Factor:** In the standard unit a fixed K-Factor is used to convert the input pulses or frequency generated internally by the analog input to engineering units. The 8 digit K-Factor dividers, with

decimal keyed into any position, allow easy direct entry of any K-Factor greater than 0.0001 to 99999999. Separate K-Factors may be entered for the total and rate section. Thus, you may totalize in gallons and display rate in liters per hour. The maximum factored count speed is 20,000 Hz. The maximum factored rate is 7 digits.

16 POINT LINEARIZATION variable K-factor option makes flow systems more accurate and often extends their usable range by allowing users to dial in different K-factors for different flow rates. It works with either pulse input or standard analog current loop or voltage input. It is recommended for flow meters whose K-factors change with different rates of flow. From 3 to 16 points of frequency (0 to 10,000 Hz) and K-factors (.0001 to 999,999) are dialed in at set up. The unit uses 8 digit floating math to interpolate between settings. Rate per second, per minute or per hour programmability eliminates the need to calculate separate K-factors for total and rate.

**Outcard:** RS232 or RS422 serial two way communication options are available. Several units can be linked together and addressed separately to transmit unit status or accept new set points in the standard ASCII format. Baud rates of 300, 600, 1200, 2400, 4800 or 9600 as well as choice of odd, even, space or mark parity can be selected by keypad control.

**Termination:**

- 1•Not Used
- 2•Scaled Pulse Output O.C.
- 3•Analog Output (Sink)
- 4•Input A (Pulse/Analog)
- 5•Reset Input
- 6•Not Used
- 7•Not Used
- 8•Not Used
- 9•Not Used
- 10•Not Used
- 11•Ground (-DC)
- 12•Ground (-DC)
- 13•+12 Volts Out
- 14• +DC Power In
- 15•Isolate -12 Volts
- 16•Isolate +12 Volts
- 17•AC In
- 18•AC In
- 19•Preset B Open Collector
- 20•Preset A Open Collector

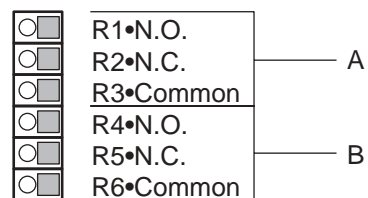



## Pulse Input With Analog Output

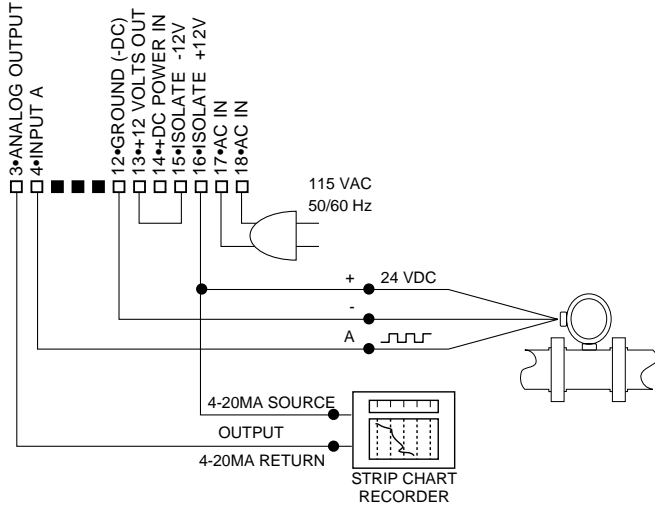

## Dimensions:

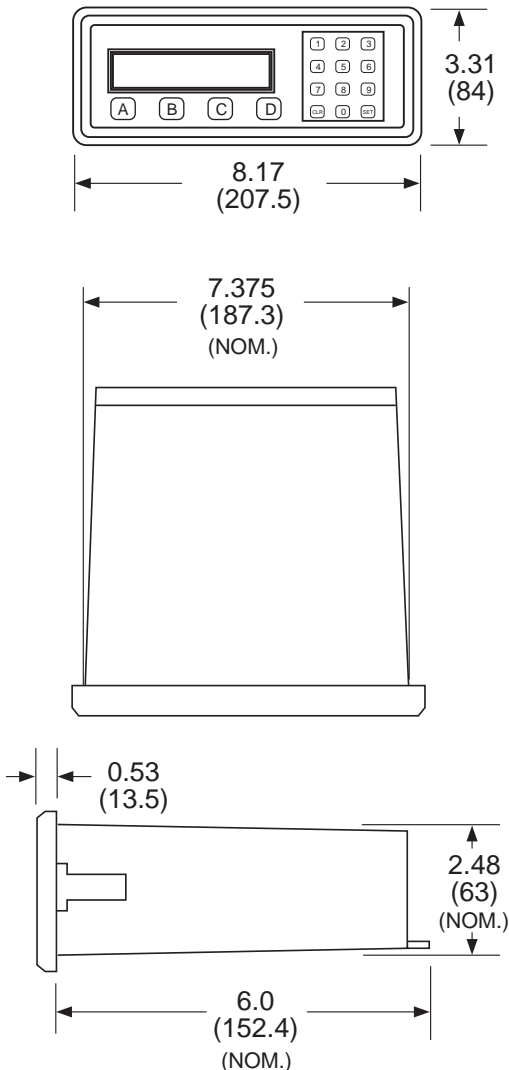

## Pulse Output Wiring

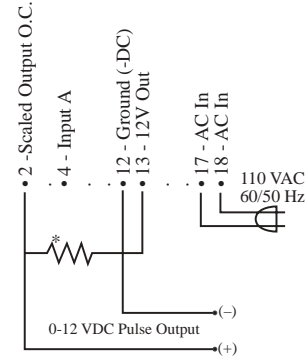

\* Must be greater than 150 Ohms

## Ordering Information

Example **KRT8 A 3A 2 A 13**

### Series:

KEPtrol R/T

### Operating Voltage:

A: 110 VAC  $\pm 15\%$  or 12 to 27 VDC

B: 220 VAC  $\pm 15\%$  or 12 to 27 VDC

### Control Inputs:

\* 3A: STD Pulse 3-30 VDC 20 kHz Max.

\* 3B: As 3A, with 4.7 K $\Omega$  pull up resistors

5A: 4-20 mA

5B: 0-20 mA

5C: 1-5 VDC

5D: 0-5 VDC

5E: 0-10 VDC

6A: 4-20 mA Square Law

7A: 4-20mA in, 4-20mA out

7B: 0-20mA in, 4-20mA out

7C: 1-5VDC in, 4-20mA out

7D: 0-5VDC in, 4-20mA out

7E: 0-10VDC in, 4-20mA out

### For Other Outputs:

Add X for 0-20mA out

Add Y for 0-5V out

Add Z for 0-10V out

### Control Outputs:

1: Open Collector (optional)

2: SPDT Relay 10A (standard)

### Input Speed:

\* A: 0-40 CPS (Inputs 3A, 3B)

\* C: 0-400 CPS (Inputs 3A, 3B)

\* E: 0-20K CPS (Inputs 3A, 3B)

K: Inputs 5A-5E, 6A, 7A-7E

\* Dip switch selectable, all units can be field modified easily.

### Options: (Multiple Options Available)

1: RS232 Serial Interface

2: RS422 Serial Interface

3: 4-20 mA Output (Input 3A or 3B only)

3X: 0-20 mA Output (Input 3A or 3B only)

3Y: 0-5VDC Output (Input 3A or 3B only)

3Z: 0-10VDC Output (Input 3A or 3B only)

4: 16 Point Linearization Opt.

ET: Extended Temperature:

-40° to 158°F (-40° to 70° C)

**ET not available with analog inputs or outputs**

UL/CSA: UL/CSA Approved Unit (pending) . (consult factory)

### Accessories:

NEMATROL- NEMA 4X/IP 65 Enclosures (see Accessories)

FLEXCOVER #36120

XTROL7/4- Explosion proof housing (see Accessories)

Serial printer available, see P1000, P295

Ethernet Port Server available, see IEPS

RS-422/485 to RS-232 Communication Adaptor available, see CA285

# RTP

*Two Separate Ratemeters, Totalizers  
With Two Line LCD Display*

## Features

- Two pulse and three control inputs
- Displays: A Rate, A Total, B Rate, B Total, A+B Rate, A+B Total, A-B Rate, A-B Total, Grand Total
- Separate Scaling Factors For A & B Inputs
- Two relay outputs with LED Indication
- RS232/ RS485 port for serial communication and printing
- Security lockout
- 4-20 mA output (optional)



- NVRAM to retain data on power failure
- NEMA 4 / IP65 Front Panel

## DESCRIPTION:

The RTP is a presettable Ratemeter and Totalizer from two pulse inputs. It can show rate and total at the same time on the 2 X 16 backlit LCD display. Both inputs can have up to 16 point linearizing k factors. The unit can be connected in a network for Data Acquisition.

## SPECIFICATIONS:

**INPUT POWER:** AC: 85 to 265 VAC; 6.5 VA  
DC: +24 VDC ; 250 mA max.

**THRESHOLD:** High: 4-24 VDC; Low: < 1Vdc or open

**INPUT A:** Count Input, 5 kHz max.

**INPUT B:** Count Input, 5 kHz max.

**INPUT C:** Control Input

**INPUT D:** Control Input

**INPUT E:** Control Input (Not Used with RS485)

**MAG INPUT(3MB):** Inputs A & B, accepts 30mV input (30 V max. P/P) signals 10 K $\Omega$  imp. 5 kHz max.

**NOTE:** AC powered units have isolated inputs. DC units share -DC with input common.

**OUTPUT POWER:** +20VDC @50 mA (unreg), +/- 15%

**DISPLAY:** 2 lines of 16 characters, backlit LCD (character size: 2.95mm x 5.55mm)

**BEZEL:** NEMA 4/IP65 rated membrane keypad

**INDICATORS:** Two LED's to indicate control output status. (Red = Output A, Green = Output B)

**MEMORY:** NVRAM retains data on power failure

**TEMPERATURE:** Operating : 0 to 50 degrees C  
Storage : -40 to 90 degrees C

**HUMIDITY:** 10% to 90% ( Non condensing )

**SIZE:** Bezel: 103mm X 55 mm; Depth:97 mm

**PANEL CUTOUT:** 92 mm X 45 mm (1/8 DIN size cutout )

**IMMUNITY TO ESD:** Level 3 per IEC1000-4-2

**IMMUNITY TO TRANSIENTS:** Level 3 per IEC1000-4-4

**RADIATED SUSCEPTIBILITY:** Level 3 per IEC1000-4-3

**EMISSIONS:** EN55011 CISPR A

## PULSE INPUTS

The RTP can accept two pulse inputs ( A&B ). It computes rate and total of A, B, A+B and A-B. For both inputs the user can define up to 16 points of "k" factors. This allows linearization of the displayed rate, which is useful in improving the accuracy of the flowmeter.

The rate is computed within 300 ms per input. To stabilize the rate display, the user can select normalizing factor, which allows weighted average to be shown. Moreover, for rate displays, a time delay of up to 25 seconds can also be selected.

## CONTROL INPUTS

The RTP has three Control Inputs, i.e. Input C, Input D and Input E (Only C & D with RS485 option). Each input can be configured to start/stop each counter or reset each counter and Control Output. These inputs can also perform different control actions like printing on serial port, lock unit and freeze display.

## RESET OPTIONS

The entire unit, i.e. all counters and control outputs, or Counter A, Counter B, Counter A+B, Counter A-B, Control O/P A and Control O/P B can be individually programmed to be reset on pressing the front panel RST key and also by a positive edge signal to any of the Control I/Ps C, D and E.

## SERIAL COMMUNICATION

The serial strobed port can be used for serial printing of Total or Rate data with descriptors. The unit can also communicate with a master device through a Modbus-RTU protocol. The data given for each parameter is in IEEE float format comprising of 2 words. The unit can be connected in a network. Order Option 1 is RS-232 level format; Order Option 2 is RS-422/485 level format.

## CONTROL OUTPUTS

RELAY: 2 N.O. relays of 5 A and 250 V

## ANALOG OUTPUT:

Type: 4-20 mA output.

Accuracy:  $\pm 50\mu\text{A}$  worst case.

This Analog O/P can be programmed to track any parameter. Reverse tracking O/P is also available.

**PRESETS:** The unit supports five counters, i.e. Counter A, Counter B, Counter A+B, Counter A-B and Grand Total. The counters can either be reset to zero or disabled. Relays can be activated by any of the Total or Rate values. If a Total preset activates the relay, the user can select an output duration of 0.1 to 99.9 seconds with instant auto reset to "0". A 00.0 duration keeps the relay activated until externally

reset. If both presets are assigned to same counter, with Relay A duration set to 00.0 and Preset A lower than Preset B, Relay A pulls in at Preset A and drops out when Preset B (having a duration other than 00.0) pulls in. Counter recycles immediately, and Relay B stays activated for the selected duration.

If activated by rate, the relay pulls in at High Preset or above and remains on until rate falls below Low Preset.

**LOCKOUT:** The unit program and presets can be protected with a lock code to prevent unauthorized front panel changes. This code can be assigned with a maximum of 4 digits and is user selectable. It can be entered through front panel LOCK key or by configuring any of the Control I/Ps to "Lock unit". Alternate entry of the lock code or pulses to that I/P will lock or unlock the unit.

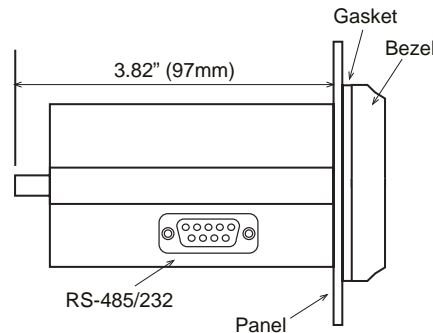
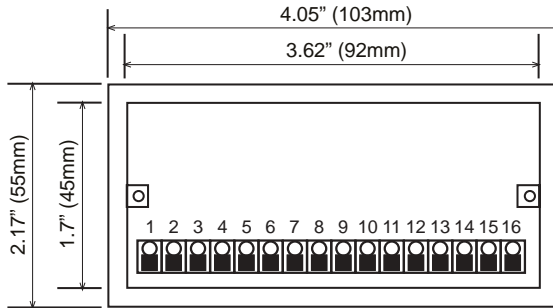

## Terminal Designations:

- 1 • AC1 (85 TO 265VAC)
- 2 • AC2 (85 TO 265VAC)
- 3 • RELAY B
- 4 • COMMON
- 5 • RELAY A
- 6 • COMMON
- 7 • (+) 20VDC OUT (50mA) (unregulated)
- 8 • (-) 20VDC OUT (50mA) (unregulated)
- 9 • ANALOG O/P (+)
- 10 • ANALOG O/P (-)
- 11 • CTRL I/P E
- 12 • CTRL I/P D
- 13 • CTRL I/P C
- 14 • PULSE I/P B
- 15 • PULSE I/P A
- 16 • INPUT GND

## Communication Port Terminal Designations:



- 1 • Transmit B (-)
- 2 • Receive B (-)
- 3 • N.C.
- 4 • N.C.
- 5 • Ground
- 6 • N.C.
- 7 • N.C.
- 8 • Receive A (+)
- 9 • Transmit A (+)



- 1 • N.C.
- 2 • Transmit
- 3 • Receive
- 4 • N.C.
- 5 • Ground
- 6 • Strobe
- 7 • N.C.
- 8 • N.C.
- 9 • N.C.

## Ordering Information

Example: RTP A 3 1

Series: \_\_\_\_\_  
 RTP= Pulse Input Ratemeter/Totalizer

Operating Voltage: \_\_\_\_\_

A= 110 VAC  $\pm 15\%$

B= 220 VAC  $\pm 15\%$

C= 24 VDC

Input: \_\_\_\_\_

3= Standard, 4-30 VDC simultaneous inputs

3MB= Mag. Input, inputs A & B 30mV input (24VDC Powered units only)

Options: \_\_\_\_\_

1= RS-232, 3 Control Inputs (not available with RS-485)

2= RS-485/Modbus-RTU, 2 Control Inputs (not available with RS-232)

A= 4-20 mA Out (Can be ordered with options 1 or 2)

Accessories

NEMA 4X wall mount enclosure available, see NEMA-1/8DIN

XHV 7/4 Explosion Proof Housing available, see XHV7/4

Serial printer available, see P1000, P295

Ethernet Port Server available, see IEPS

RS-422/485 to RS-232 Communication Adaptor available, see CA285

## KEYPAD FUNCTIONS

KEY	Run Mode	Program Mode
PROG	Enter The Programming Mode	Toggles between menus
VIEW	VIEW key scrolls through the selected viewing parameters	Left key shifts digits in number entry/characters in message mode
PRE A	PRE A key allows Preset A to be changed if unit is not locked	Up key increments digits/characters
CLR PRE B	PRE B key allows Preset B to be changed if unit is not locked	CLR key clears the numeric field
ENT LOCK	Lock Key allows the entry of a lock code to lock/unlock the unit	ENT key saves changes and steps to next menu
RST	RST Key resets counters (with/without confirmation)	Unit comes out of programming at any level

# MS-716

*Flow Totalizer, Ratemeter and Batcher for Vehicle & Skid Mounting*

## Features

- NEW! - Vehicle Mount Enclosure; Rugged Aluminum Construction
- Provisions for Sealing
- "EZ Setup" Guided Setup for First Time Users
- Rate/Total and Batching Functions
- Menu Selectable Hardware & Software Features
- Universal Viscosity Curve (UVC) and API Eq.
- Advanced Batching Features: Overrun Compensation, Autobatch Start, Print End of Batch, Slow Fill, 2 Stage Batching
- Isolated Outputs Standard
- RS-232 Port Standard, RS-485 Optional
- Advanced Printing Capabilities
- Windows™ Setup Software
- On Board Data Logging
- DDE Server & HMI Software Available
- Enhanced Modem Features for Remote Metering
- Quick Batching Sequence with Automatic Ticket Printing



## Description:

The MS-716 is a special version of the SUPERtrol-1 Flow Computer which is supplied in a vehicle mount enclosure. The MS-716 satisfies the instrument requirements for a variety of flowmeter types in liquid applications. Multiple flow equations and instrument functions are available in a single unit with many advanced features.

The alphanumeric display shows measured and calculated parameters in easy to understand format. Single key direct access to measurements and display scrolling is supported

The versatility of the MS-716 permits a wide measure of versatility within the instrument package. The various hardware inputs and outputs can be "soft" assigned to meet a variety of common application needs. The user "soft selects" the usage of each input/output while configuring the instrument.

The isolated analog output can be chosen to follow volume flow, corrected volume flow, mass flow, temperature, or density by means of a menu selection. Most hardware features are assignable by this method.

The user can assign the standard RS-232 Serial Port for data logging, transaction printing, or for connection to a modem for remote meter reading.

A Service or Test mode is provided to assist the user during start-up system check out by monitoring inputs and exercising outputs and printing system setup.

## Specifications:

### Flow Meters and Computations

Meter Types: All linear and square law meters supported including: Coriolis, vortex, turbine, magnetic, PD, target, orifice, venturi, v-cone and many others  
Linearization: Square root, 16 point table or UVC table  
Computations: Volume, Corrected Volume & Mass  
Fluid Computations: Temperature, Density, Viscosity and API 2540 for petroleum.

### Environmental

Operating Temperature: -4°F to +131°F (-20°C to +55°C)  
Storage Temperature: -40°C to +85°C  
Humidity : 0-95% Non-condensing  
Materials: U.L. approved

**Listing:** UL/ULC Listed (File No. E192404), CE Compliant

### Display

Type: 2 lines of 20 characters  
Types: Backlit LCD  
Character Size: 0.3" nominal  
User programmable label descriptors and units of measure

### Keypad

Keypad Type: Membrane Keypad with 16 keys

### Enclosure

Size: See Dimensions  
Seal: NEMA4X  
Materials: Aluminum

### Real Time Clock

The MS-716 is equipped with a battery backed real time clock with display of time and date.  
Format:  
12 or 24 hour time display  
Day, Month, Year date display

### Power Input

The factory equipped power option is internally fused. An internal line to line filter capacitor and MOV are provided for added transient suppression.

110 VAC Power: 85 to 127 Vrms, 50/60 Hz  
220 VAC Power: 170 to 276 Vrms, 50/60 Hz  
DC Power:  
12 VDC (10 to 14 VDC)  
24 VDC (14 to 28 VDC)

Power Consumption:  
AC: 11.0 VA (11W)  
DC: 300 mA max.

## Flow Inputs:

### Analog Input:

Accuracy: 0.01% FS at 20° C

#### Ranges

Voltage: 0-10 VDC, 0-5 VDC, 1-5 VDC

Current: 4-20 mA, 0-20 mA

Basic Measurement Resolution:

16 bit

Update Rate: 4 updates/sec

Automatic Fault detection: Signal over/under-range,  
Current Loop Broken

Calibration: Software Calibration (no trimmers) and  
Auto-zero Continuously

Extended calibration:

Learns Zero and Full Scale of each range using  
special test mode.

Fault Protection:

Reverse Polarity: No ill effects

Over-Voltage Limit: 50 VDC Over voltage  
protection

Over-Current Protection: Internally current limited  
protected to 24VDC

### Pulse Inputs:

Number of Flow Inputs: one with or without quadrature

Input Impedance: 10 K $\Omega$  nominal

Pullup Resistance: 10 K $\Omega$  to 5 VDC (menu selectable)

Pull Down Resistance: 10 K $\Omega$  to common

Trigger Level: (menu selectable)

High Level Input

Logic On: 3 to 30 VDC

Logic Off: 0 to 1 VDC

Low Level Input (mag pickup)

Sensitivity:

10 mV or 100 mV

Minimum Count Speed:

Menu selectable

Maximum Count Speed:

Menu Selectable: 40Hz, 3000Hz or 20 kHz

Overvoltage Protection: 50 VDC

### Auxiliary / Compensation Input

The auxiliary/compensation input is menu selectable for temperature, density or not used. This input is used for the compensated input when performing compensated flow calculations and using volumetric flowmeters. It can also be used as a general purpose input for display and alarming.

Operation: Ratiometric  
 Accuracy: 0.01% FS at 20° C  
 Basic Measurement Resolution: 16 bit  
 Update Rate: 1 update/sec minimum  
 Automatic Fault detection:  
     Signal Over-range/under-range  
     Current Loop Broken  
     RTD short  
     RTD open  
     Fault mode to user defined default settings  
 Fault Protection:  
     Reverse Polarity: No ill effects  
     Over-Voltage Limit (Voltage Input): 50 VDC  
 Available Input Ranges  
     Voltage: 0-10 VDC, 0-5 VDC, 1-5 VDC  
     Current: 4-20 mA, 0-20 mA  
     Resistance: 100 Ohms DIN RTD

100 Ohm DIN RTD  
 (DIN 43-760, BS 1904):  
     Three Wire Lead Compensation  
     Internal RTD linearization learns ice point resistance  
     1 mA Excitation current with reverse polarity protection  
     Temperature Resolution: 0.01 C

### Control Inputs

Switch Inputs are menu selectable for Start, Stop, Reset, Lock, Inhibit, Alarm Acknowledge, Print or Not Used.

Control Input Specifications  
 Input Scan Rate: 10 scans per second  
 Logic 1: 4 - 30 VDC  
 Logic 0: 0 - 0.8 VDC  
 Input Impedance: 100 KΩ  
 Control Activation:  
     Positive Edge or Pos. Level based on product definition for switch usage.

### Excitation Voltage

Menu Selectable: 5, 12 or 24 VDC @ 100 mA (fault protected)  
**NOTE:** DC powered units have limited excitation voltage

### Relay Outputs

The relay outputs are menu assignable to (Individually for each relay) Low Rate Alarm, Hi Rate Alarm, Prewarn Alarm, Preset Alarm or General purpose warning (security), low temperature/high temperature.

Number of relays: 2 (4 optional)  
 Contact Style: Form C contacts  
 Contact Ratings: 5 amp, 240 VAC or 30 VDC

### Serial Communication

The serial port can be used for printing, datalogging, modem connection and communication with a computer.

RS-232:  
     Device ID: 01-99  
     Baud Rates: 300, 600, 1200, 2400, 4800, 9600, 19200  
     Parity: None, Odd, Even  
     Handshaking: None, Software, Hardware  
 Print Setup: Configurable print list and formatting.  
     Print Out: Custom form length, print headers, print list.  
 Print Initialization: Print on end of batch, key depression, interval, time of day or remote request.

RS-485: (optional 2nd COM port)  
     Device ID: 01-247  
     Baud Rates: 1200, 2400, 4800, 9600, 19200  
     Parity: None, Odd, Even  
     Protocol: Modbus RTU (Half Duplex)

### Data Logging

The data logger captures print list information to internal storage for approximately 1000 transactions. This information can be used for later uploading or printing. Storage format is selectable for Comma-Carriage Return or Printer formats.

### Isolated Analog Output

The analog output is menu assignable to correspond to the Uncompensated Volume Rate, Corrected Volume Rate, Mass Rate, Temperature, Density, Volume Total, Corrected Volume Total or Mass Total.  
 Type: Isolated Current Sourcing  
 Available Ranges: 4-20 mA, 0-20 mA  
 Resolution: 12 bit  
 Accuracy: 0.05% FS at 20° C  
 Update Rate: 1 update/sec minimum  
 Temperature Drift: Less than 200 ppm/C  
 Maximum Load: 1000 ohms (at nominal line voltage)  
 Compliance Effect: Less than .05% Span  
 60 Hz rejection: 40 dB minimum  
 Calibration: Operator assisted Learn Mode  
 Averaging: User entry of damping constant to cause a smooth control action

**NOTE:** DC powered units are not isolated

### Isolated Pulse output

The isolated pulse output is menu assignable to Uncompensated Volume Total, Compensated Volume Total or Mass Total  
 Pulse Output Form: Photomos Relay  
 Maximum On Current: 25 mA  
 Maximum Off Voltage: 30 VDC  
 Saturation Voltage: 1.0 VDC  
 Maximum Off Current: 0.1 mA  
 Pulse Duration: 10 mSec or 100 mSec (user selectable)  
 Pulse output buffer: 256  
 Fault Protection  
     Reverse polarity: Shunt Diode

## Vehicle Mount Dimensions

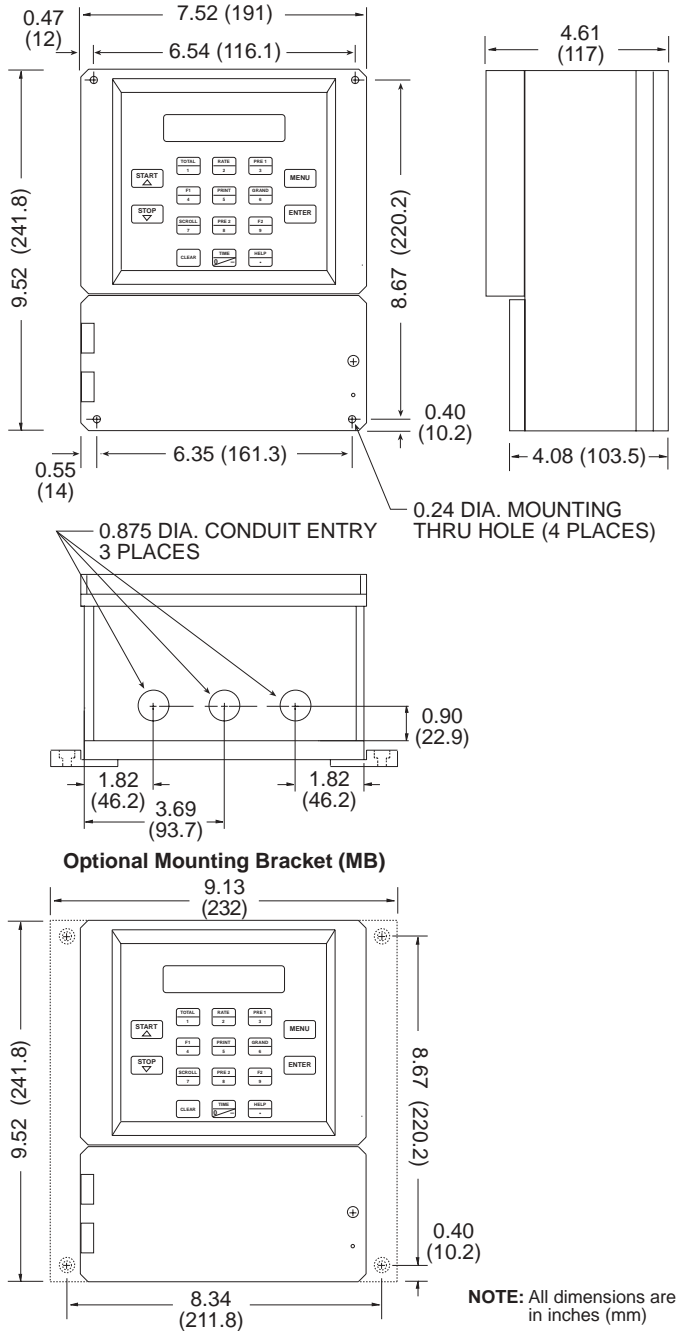

## Terminal Designations

1	DC OUTPUT	FLOW IN	
2	PULSE IN 1	Vin +	
3	PULSE IN 2	lin +	
4	COMMON		
5	RTD EXCIT +	Vin +	
6	RTD SENS +		COMP IN
7	RTD SENS -	lin +	
8	CNTR IN 1		
10	CNTR IN 2		
11	CNTR IN 3		SEE USER MANUAL
12	COMMON		
13	PULSE OUTPUT +		
14	PULSE OUTPUT -		
15	ANALOG OUTPUT +		4-20 mA
16	ANALOG OUTPUT -		
17	NC	25	COM RLY3
18	COM RLY1	26	NO
19	NO	27	NC
20	NC	28	COM RLY4
21	COM RLY2	29	NO
22	NO	30	NC
23	AC LINE	DC +	POWER IN
24	AC LINE	DC -	

## Ordering Information

Example MS716 L 1 A 0 V ETMB

Series: \_\_\_\_\_

MS716 = ST1 Special

Display Type: \_\_\_\_\_

L = LCD

Input Type: \_\_\_\_\_

- 1= 110 VAC
- 2= 220 VAC
- 3= 12 VDC (10 to 14 VDC)
- 4= 24 VDC (14 to 28 VDC)

Relays: \_\_\_\_\_

- A= 2 SPDT Relays
- B= 4 SPDT Relays

Network Card: \_\_\_\_\_

- 0= None (STD)
- 2= RS485/Modbus

Mounting: \_\_\_\_\_

- V= Vehical Mount, Skid Mount, Field Mount

Options: \_\_\_\_\_

- ET= Extended Tempertaure  
-4°F to 131°F (-20°C to 55°C)
- UL= UL Class 1 Division 2
- MB= Aluminum Mounting Brackets (2) (Recommended)
- IM = IM-2400 Internal Modem
- M = Modem Power Option
- TB= RS485 Terminal Block  
for Panel Mount Enclosure

Accessories:

KEPS-KEP1-32

KEP RS232 for SUPERtrol 1, SUPERtrol 1LE,  
SUPERtrol 2 and LEVELtrol 2 • 32 Bit OPC/DDE Server

KEPS-MBS32

Supports RS485 for ST1, ST1LE, ST2,  
LT2, MRT, DRT & MB2 (Modbus RTU)

Modem Available, see MPP-2400 and MPP-2400N

Serial printer available, see P1000, P295

Ethernet Port Server available, see IEPS

RS-422/485 to RS-232 Communication Adaptor available, see CA285

Remote metering and data collection software available, see TROLlink

# Batching Tutorial

**What is a Flow Batch Controller?** A special purpose instrument which is intended to be used in conjunction with a flow sensor and a control valve to dispense a desired amount of a fluid into a container, tank, or vehicle. In some cases the temperature may also be used to estimate the fluid density from stored fluid properties.

**How does a Batcher Work?** The basic batcher is illustrated in the figures below. The operator begins by entering the desired amount of fluid to be dispensed into a batch quantity setpoint on the instrument. The Start button is pushed. The valve opens and the vessel begins filling. The flow sensor sends the flow signal to the batcher. The batcher compares the total amount delivered and shuts the valve when the desired amount has been dispensed.

**What is batch overrun and how do I prevent it?** Batch overrun is the term given for the amount of fluid dispensed which is greater than the setpoint which was entered. Batch overrun results from the delay in the valve closing. Two techniques are used to minimize batch overrun. See Batch Overrun Compensation and Two Stage Batching.

**Batch Overrun Compensation-** This technique uses a feature in some batchers which "learn" the amount of batch overrun and then seek to turn the batch off "early" by the average amount of the batch overrun. This feature may be enabled or disabled in some models.

**Two Stage Batching-** This technique for reducing Batch Overrun uses two valves, one slow fill and one fast fill, to reduce the flow rate just before the batch ends to reduce the amount of overrun. The user can enter the prewarn value for the slow fill at the end of the batch.

**Slow Fill-** This is a technique used in conjunction two stage batching where a vessel is initially filled at a slow rate to prevent splashing before the fast fill begins. The user can enter the amount of fluid to be filled during the slow fill.

**Count Mode-** In general, a batcher may be configured to either count from 0 up to the batch quantity or to count down from the batch quantity to 0.

**Maximum Batch Preset-** This is a safety feature which places a limit on the maximum batch size the operator may enter. It is intended to eliminate large operator entry errors.

**Batch Auto Restart-** This is a capability which may be used in some applications where the same size container will be filled repeatedly. A programmable time is allowed for the removal of the previously filled container and the repositioning of the new empty container between batches.

**Flow Time Out or Security-** This is a safety feature which automatically stops a batch when a loss of flow signal is encountered for longer than a user programmed time while a batch is in progress. It is intended to prevent a spill in the event of a failed flow sensor.

**Drain Time-** This is a feature in some batchers which delays the print of batch record for a user programmable time to permit draining of a fluid into the receiving vessel.

**Printing Capability-** Many batchers support the generation of a transaction printout. Usually a RS-232 port is provided which may be connected to a printer. A transaction print may be generated manually by pressing a PRINT key, or automatically. The format of the printout and the information which it contains are usually selectable by the user.

**Print on End of Batch-** This is a capability to automatically create a print out when a batch has been completed by sending out a report on a RS-232 port to a local printer.

**Overrun Alarm Detection-** This is a safety feature which generates an alarm if the batch quantity has exceeded the desired batch size by more than the allowed limit. It is intended as a safety measure to notify the user of a malfunctioning valve which has failed to close on command.

**Remote Start/Stop/Clear Capability-** Many batchers have provisions for wiring remote switches or contact closure such that a remote operator or system can control the starting and stopping of a batcher.

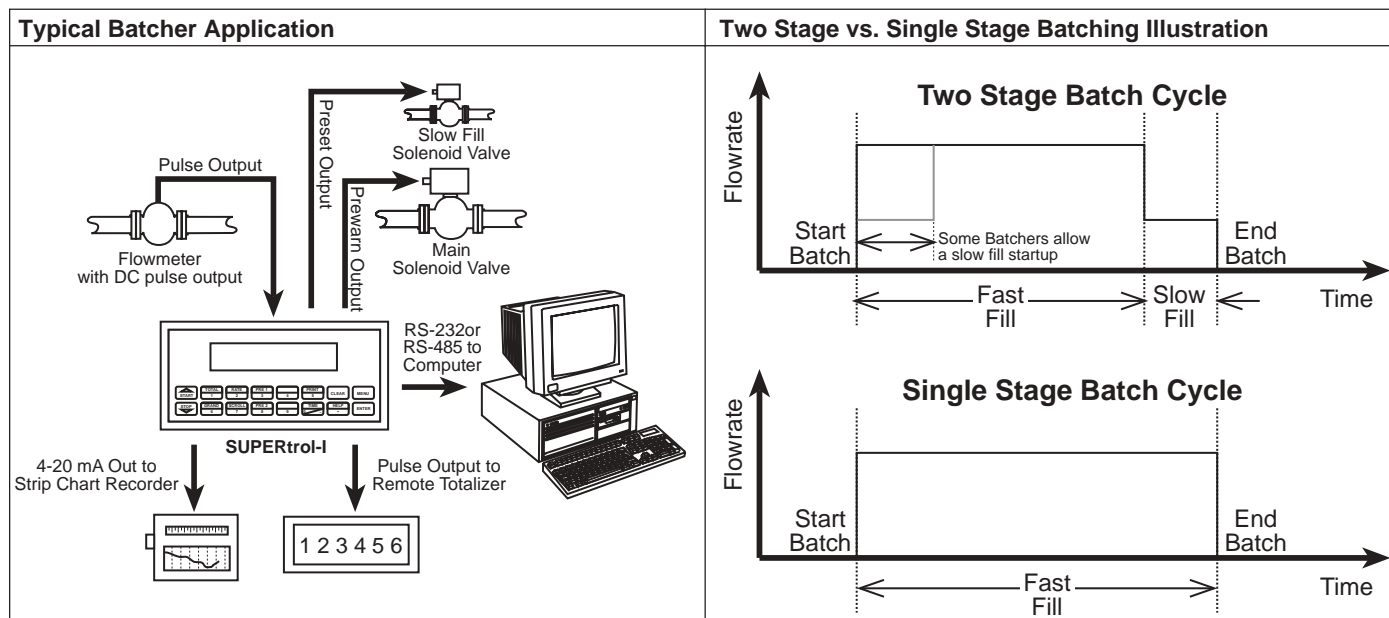



# MB2 (MINI-Batcher)

## Low Cost, Pulse Input Batch Controller

### Features

- 5 Digit Scaling Factor
- Display Rate, Batch Size and (Number of Batches or Grand Total)
- Second B Relay Programmable for Output at Prewarn or selected Batch/Grand Total
- Pulse Input - 10 kHz Max.
- Security Lockout
- RS422/RS232 Serial Communication Option
- Modbus RTU RS422/RS485/RS232
- NEMA 4X / IP65 Front Panel

### Application:

This miniature batcher is ideal for all batching applications. The display will show Batch Amount, Rate and Batch/Grand Total at the push of a button. The Start and Stop buttons make batching simple.

### Description:

The MINI-Batcher is a 6 digit totalizer and 4.5 digit ratemeter with two relay outputs. One output is dedicated to the batch amount (Preset A), the other can be activated for Prewarn or Batch/Grand Total. The unit can count up to the preset (reset to 0) or down from the preset (set to preset). Start, Stop and Reset functions can be activated from the front panel or remote inputs. An analog output (assignable for Rate or Batch Amount) is available for data logging. Several units can communicate to a host computer on a single RS232 or RS422 loop.

### Specifications:

**Display:** 6 digit, 0.55" High LED

#### Input Power:

110 VAC  $\pm$  15% or 12 to 15 VDC  
220 VAC  $\pm$  15% or 12 to 15 VDC  
24 VAC  $\pm$  15% or 12 to 15 VDC

**Current:** 250 mA DC max. or 6.5 VA (6.5W) AC

**Output Power:** (AC powered units only)  
+12 VDC @ 50 mA, unregulated -10 + 50%

#### Temperature:

Operating:

+32°F (0°C) to +130°F (+54°C)

Storage:

-40°F (-40°C) to +200°F (93°C)

**Humidity:** 0-90% Noncondensing

**Memory:** EEPROM stores data for 10 years if power is lost.

**Listing:** CSA (File No. LR91109), CE Compliant,  
NRTL/C pending



- 30mV Magnetic Pickup Input Option
- 4-20mA or 0-20mA Analog Output Option

### Inputs:

- 3: High Impedance DC pulse input 4-30 VDC (high), Open or 0-1 VDC (low), 10 k $\Omega$  impedance, 10 kHz max. speed.
- 3M: Mag. Input, accepts 30mV input (50 V max.) signals 10 K $\Omega$  imp. 5 kHz max.

### Stop / Reset:

Front Panel:

STOP/RST button stops batch if batch is running, Resets displayed value and control output if batch is stopped.

Remote:

4-30 VDC, positive edge: stops batch if batch is running, Resets batch amount if batch is stopped.

**NOTE:** Hold either front or remote reset active to inhibit any start inputs.

**Scaling Factor (K-Factor):** A user programmable K-Factor is used to convert the input pulses to engineering units. The 5 digit K-Factor divider, with decimal keyed into any position, allows easy direct entry of any K-Factor from 0.0001 to 99999.

**Presets:** Two control outputs are provided. A 5 digit value can be entered for both presets. The decimal point location is the same as the counter (No decimal in Batch Total counter).

**PRESET A:**

The preset A output is dedicated to the batch amount. When START is activated, Relay A will energize and remain on until the batch is complete or the batch is stopped.

**PRESET B:**

The preset B output can be programmed to activate as a Prewarn (for two stage batch control) or activate on Batch Total (number of batches) or Grand Total (selectable). When set for PREWARN, Relay B will energize when START is activated and drop out at Prewarn number before preset. When set for Batch Total (number of batches) or Grand Total, Relay B will activate when the batch total or grand total counts up to preset B amount. The output ON time can be set for a duration (0.01 to 99.99 sec.) or latched (0.00 setting). If a value other than 0.00 is set for the duration, the batch total (number of batches) or grand total will auto-reset at preset B.

**Control Outputs:**

Relays:

2 each N.O. Relay; 5 Amps 120/240 VAC or 28 VDC. (N.C. relay contacts and NPN transistor output available with solder jumpers.

Analog Output:

An optional 4-20mA (0-20mA) output is available for the Mini-Batcher series. The output can be programmed to track rate or batch amount. Connections are via a 2 terminal pluggable screw connector. Programming is accomplished by using the front panel in conjunction with rear dip switches. Accuracy: ±.25% FS worst case. Compliance Voltage: 3 to 30 VDC non inductive.

**Lockout:** Unauthorized front panel changes can be prevented by entering a user selected 5 digit code. The front panel can be completely locked out (except Start & Stop) or the preset can remain accessible.

**Ratometer:** Accuracy: 0.01% FS (±1 display digit).

The rate display updates once per second. The rate meter can be programmed to sample from 2 to 24 seconds maximum, and auto-range up to 5 digits of significant information. The ratemeter displays in units per second, minute or hour.

**Batch or Grand Totalizer:** In addition to viewing the batch amount, a second counter can be viewed. This counter is pro-

grammable to count either the number of batches (Batch Total) or the grand total count (Grand Total).

**RS232/RS422 with KEP Protocol:**

If the serial interface option is supplied, up to 99 units can be linked together. (The terminal addressing the unit must be capable of driving all loads in the loop.) Unit status and new set points can be communicated by serial communication. Mode changes, however, must always be made on the front panel.

Data is received and transmitted over standard EIA RS232 or RS422 levels. Unit number, baud rate and parity are entered in the "Program Setting" set up mode and remain in memory even if power is off.

**RS232/RS422/RS485 with Modbus RTU Protocol:**

The serial port can be used for serial printing or also for data acquisition. The unit can address up to 247 units (The terminal addressing the unit must be capable of driving all loads in the loop.) The unit can communicate with a master device through a Modbus-RTU protocol. The data given for each parameter is in IEEE float format comprising of 2 words. The unit can be connected in a network.

Device ID: 01-247

Baud Rates: 300, 600, 1200, 2400, 4800, 9600

Parity: None, Odd, Even

Protocol: Modbus RTU (Half Duplex)

**Dimensions:**

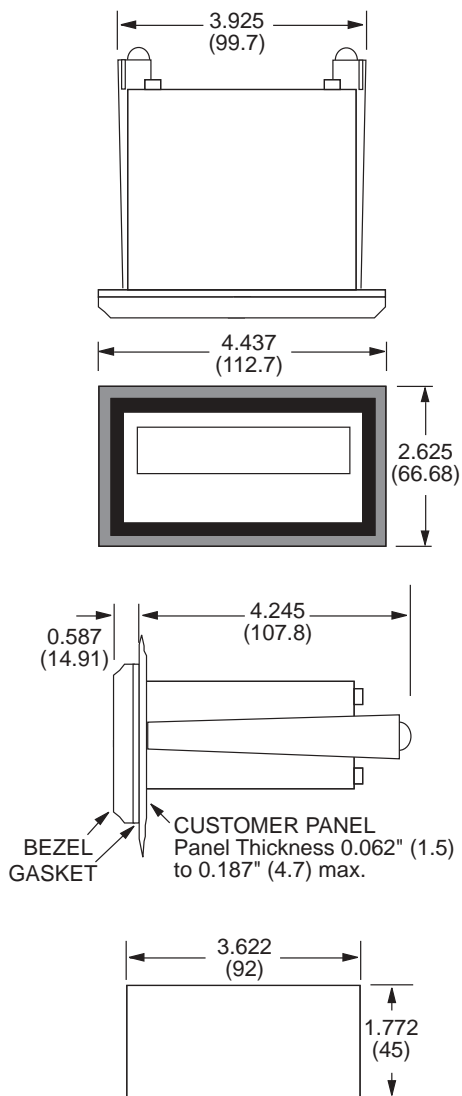

**Wiring:**

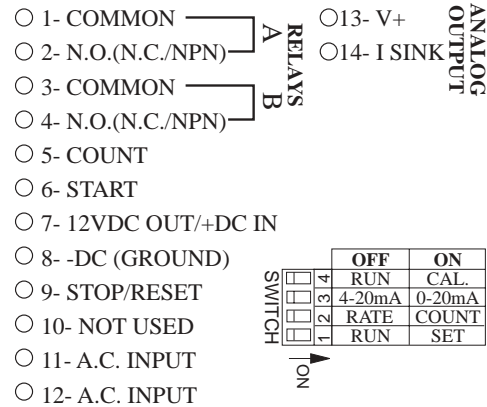

**Ordering Information**

**Example:** MB2 A 3 1

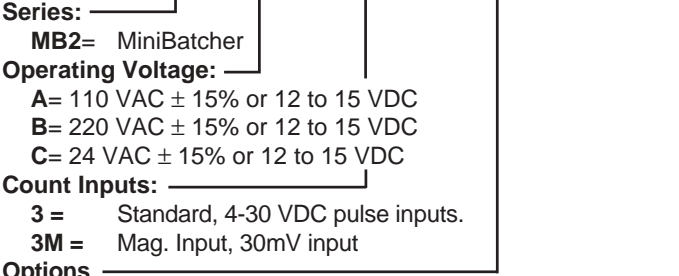

**Options**

- 1= RS232 Communications
- 2= RS422 Communications
- 3= Modbus RTU RS232
- 4= Modbus RTU RS422/RS485
- A= Analog Output (4-20/0-20 mA)

**NOTE:** RS232/RS422/RS485 & Analog Output options can not be combined

**Accessories**

- Separate keyboard panel - order #34569
- NEMA4 wall mount enclosure available, see NEMAtr0l
- Explosion proof enclosure available, see XHV
- Serial printer available, see P1000, P295
- Ethernet Port Server available, see IEPS
- RS-422/485 to RS-232 Communication Adaptor available, see CA285
- Modbus DDE/OPC Server available, see KEPserver

# SUPERtrol-I

## Multi-Function Flow Totalizer, Ratemeter and Batcher

### Features

- "EZ Setup" Guided Setup for First Time Users
- Rate/Total and Batching Functions
- Menu Selectable Hardware & Software Features
- Environmental Compliance Monitoring and Report Generation
- Universal Viscosity Curve (UVC) and API Eq.
- Advanced Batching Features: Overrun Compensation, Autobatch Start, Print End of Batch, Slow Fill, 2 Stage Batching
- Isolated Outputs Standard
- RS-232 Port Standard, RS-485 Optional
- Advanced Printing Capabilities
- Windows™ Setup Software
- DIN Enclosure with Two Piece Connectors
- On Board Data Logging
- DDE Server & HMI Software Available
- Enhanced Modem Features for Remote Metering
- NEW! - Attractive Wall Mount Enclosure

### Description:

The SUPERtrol-I Flow Computer satisfies the instrument requirements for a variety of flowmeter types in liquid applications. Multiple flow equations and instrument functions are available in a single unit with many advanced features.

The alphanumeric display shows measured and calculated parameters in easy to understand format. Single key direct access to measurements and display scrolling is supported

The versatility of the SUPERtrol-I permits a wide measure of versatility within the instrument package. The various hardware inputs and outputs can be "soft" assigned to meet a variety of common application needs. The user "soft selects" the usage of each input/output while configuring the instrument.

The isolated analog output can be chosen to follow volume flow, corrected volume flow, mass flow, temperature, or density by means of a menu selection. Most hardware features are assignable by this method.

The user can assign the standard RS-232 Serial Port for data logging, transaction printing, or for connection to a modem for remote meter reading.

A Service or Test mode is provided to assist the user during start-up system check out by monitoring inputs and exercising outputs and printing system setup.

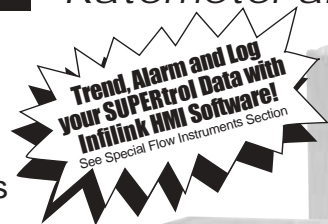

### Specifications:

#### Flow Meters and Computations

Meter Types: All linear and square law meters supported including: vortex, turbine, magnetic, PD, target, orifice, venturi, v-cone and many others

Linearization: Square root, 16 point table or UVC table

Computations: Volume, Corrected Volume & Mass

Fluid Computations: Temperature, Density, Viscosity and API 2540 for petroleum.

#### Environmental

Operating Temperature: 0°C to +50°C

Storage Temperature: -40°C to +85 C

Humidity : 0-95% Non-condensing

Materials: U.L. approved

**Listing:** UL/C-UL Listed (File No. E192404), CE Compliant

#### Display

Type: 2 lines of 20 characters

Types: Backlit LCD and VFD ordering options

Character Size: 0.3" nominal

User programmable label descriptors and units of measure

#### Keypad

Keypad Type: Membrane Keypad with 16 keys

#### Enclosure

Size: See Dimensions

Depth behind panel: 6.5" including mating connector

Type: DIN

Materials: Plastic, UL94V-0, Flame retardant

Bezel: Textured per matt finish

#### Real Time Clock

The SUPERtrol-I is equipped with a battery backed real time clock with display of time and date.

Format: 12 or 24 hour time display

Day, Month, Year date display

#### Power Input

The factory equipped power option is internally fused. An internal line to line filter capacitor and MOV are provided for added transient suppression.

110 VAC Power: 85 to 127 Vrms, 50/60 Hz

220 VAC Power: 170 to 276 Vrms, 50/60 Hz

DC Power: 12 VDC (10 to 14 VDC)

24 VDC (14 to 28 VDC)

Power Consumption:

AC: 11.0 VA (11W)

DC: 300 mA max.

**Flow Inputs:****Analog Input:**

Accuracy: 0.01% FS at 20° C

## Ranges

Voltage: 0-10 VDC, 0-5 VDC, 1-5 VDC

Current: 4-20 mA, 0-20 mA

Basic Measurement Resolution:

16 bit

Update Rate: 4 updates/sec

Automatic Fault detection: Signal over/under-range,  
Current Loop BrokenCalibration: Software Calibration (no trimmers) and Auto-  
zero Continuously

Extended calibration:

Learns Zero and Full Scale of each range using special  
test mode.

Fault Protection:

Reverse Polarity: No ill effects

Over-Voltage Limit: 50 VDC Over voltage protection

Over-Current Protection: Internally current limited  
protected to 24VDC**Pulse Inputs:**Number of Flow Inputs: one with or without quadrature or  
pulse security checkingInput Impedance: 10 K $\Omega$  nominalPullup Resistance: 10 K $\Omega$  to 5 VDC (menu selectable)Pull Down Resistance: 10 K $\Omega$  to common

Trigger Level: (menu selectable)

High Level Input

Logic On: 3 to 30 VDC

Logic Off: 0 to 1 VDC

Low Level Input (mag pickup)

Sensitivity:

10 mV or 100 mV

Minimum Count Speed:

Menu selectable

Maximum Count Speed:

Menu Selectable: 40Hz, 3000Hz or 20 kHz

Overvoltage Protection: 50 VDC

**Auxiliary / Compensation Input**

The auxiliary/compensation input is menu selectable for temperature, density or not used. This input is used for the compensated input when performing compensated flow calculations. It can also be used as a general purpose input for display and alarming.

Operation: Ratiometric

Accuracy: 0.01% FS at 20° C

Basic Measurement Resolution:

16 bit

Update Rate: 1 update/sec minimum

Automatic Fault detection:

Signal Over-range/under-range

Current Loop Broken

RTD short

RTD open

Fault mode to user defined default settings

Fault Protection:

Reverse Polarity: No ill effects

Over-Voltage Limit (Voltage Input): 50 VDC

Available Input Ranges

Voltage: 0-10 VDC, 0-5 VDC, 1-5 VDC

Current: 4-20 mA, 0-20 mA

Resistance: 100 Ohms DIN RTD

100 Ohm DIN RTD

(DIN 43-760, BS 1904):

Three Wire Lead Compensation

Internal RTD linearization learns ice point resistance

1 mA Excitation current with reverse polarity protection

Temperature Resolution: 0.01 C

**Control Inputs**

Switch Inputs are menu selectable for Start, Stop, Reset, Lock, Inhibit, Alarm Acknowledge, Print or Not Used.

Number of Control Inputs: 3

Control Input Specifications

Input Scan Rate: 10 scans per second

Logic 1: 4 - 30 VDC

Logic 0: 0 - 0.8 VDC

Input Impedance: 100 K $\Omega$ 

Control Activation:

Positive Edge or Pos. Level based on product definition for switch usage.

**Excitation Voltage**

Menu Selectable: 5, 12 or 24 VDC @ 100 mA (fault protected)

**Relay Outputs**

The relay outputs are menu assignable to (Individually for each relay) Low Rate Alarm, Hi Rate Alarm, Prewarn Alarm, Preset Alarm or General purpose warning (security), low temperature/high temperature.

Number of relays: 2 (4 optional)

Contact Style: Form C contacts

Contact Ratings: 5 amp, 240 VAC or 30 VDC

**Serial Communication**

The serial port can be used for printing, datalogging, modem connection and communication with a computer.

RS-232:

Device ID: 01-99

Baud Rates: 300, 600, 1200, 2400, 4800, 9600, 19200

Parity: None, Odd, Even

Handshaking: None, Software, Hardware

Print Setup: Configurable print list and formatting.

Print Out: Custom form length, print headers,  
print list items.Print Initialization: Print on end of batch, key depression,  
interval, time of day, control input or  
serial request.

RS-485: (optional 2nd COM port)

Device ID: 01-247

Baud Rates: 2400, 4800, 9600, 19200

Parity: None, Odd, Even

Protocol: Modbus RTU (Half Duplex)

**Data Logging**

The data logger captures print list information to internal storage for approximately 1000 transactions. This information can be used for later uploading or printing. Storage format is selectable for Comma-Carriage Return or Printer formats.

**Isolated Analog Output**

The analog output is menu assignable to correspond to the Uncompensated Volume Rate, Corrected Volume Rate, Mass Rate, Temperature, Density, Volume Total, Corrected Volume Total or Mass Total.

Type: Isolated Current Sourcing

Available Ranges: 4-20 mA, 0-20 mA

Resolution: 12 bit

Accuracy: 0.05% FS at 20° C

Update Rate: 1 update/sec minimum

Temperature Drift: Less than 200 ppm/C

Maximum Load: 1000 ohms (at nominal line voltage)

Compliance Effect: Less than .05% Span

60 Hz rejection: 40 dB minimum

Calibration: Operator assisted Learn Mode

Averaging: User entry of damping constant to cause a  
smooth control action

### Isolated Pulse output

The isolated pulse output is menu assignable to Uncompensated Volume Total, Compensated Volume Total or Mass Total

Pulse Output Form: Photomos Relay

Maximum On Current: 25 mA

Maximum Off Voltage: 30 VDC

Saturation Voltage: 1.0 VDC

Maximum Off Current: 0.1 mA

Pulse Duration: 10 mSec or 100 mSec (user selectable)

Pulse output buffer: 256

Fault Protection

Reverse polarity: Shunt Diode

### Terminal Designations

1	DC OUTPUT	FLOW	
2	PULSE IN 1	Vin +	IN
3	PULSE IN 2	lin +	
4	COMMON		
5	-----	Vin +	COMP
6	RTD EXCIT +		IN
7	RTD SENS +		
8	RTD SENS -	lin +	
9	CNTR IN 1		SEE USER
10	CNTR IN 2		MANUAL
11	CNTR IN 3		
12	COMMON		
13	PULSE OUTPUT +		
14	PULSE OUTPUT -		
15	ANALOG OUTPUT +		4-20 mA
16	ANALOG OUTPUT -		
17	NC	25	COM RLY3
18	COM RLY1	26	NO
19	NO	27	NC
20	NC	28	COM RLY4
21	COM RLY2	29	NO
22	NO	30	NC
23	AC LINE	DC +	POWER IN
24	AC LINE	DC -	

Fig. 1: Standard Dimensions

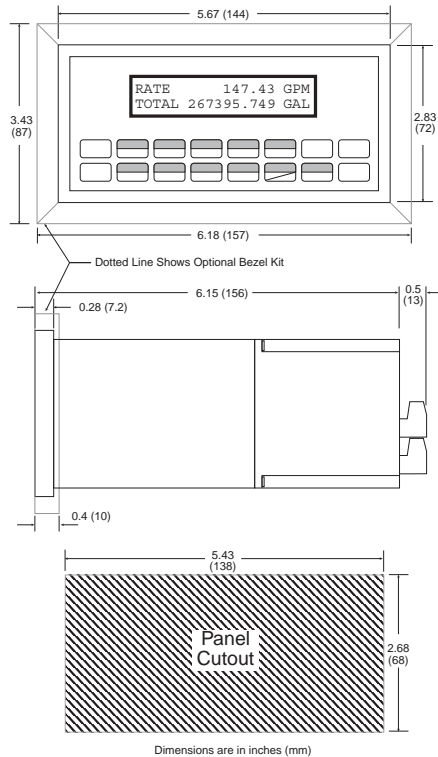
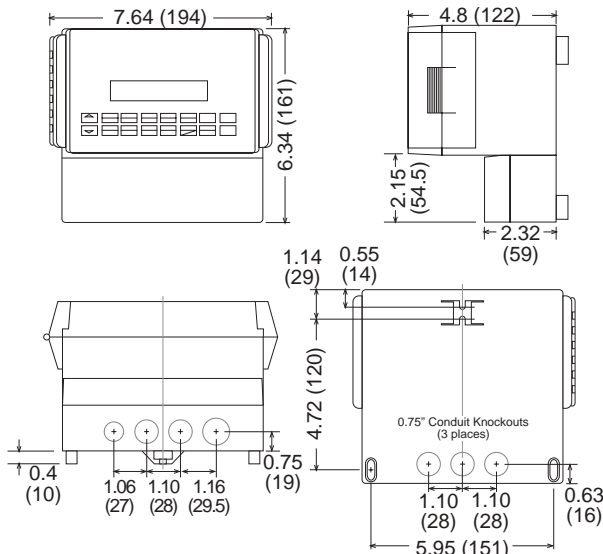

Fig. 2: Wall Mount ("W" mounting option) Dimensions



### Ordering Information

Example **ST1 L 1 A 0 P TB**

Series:

ST1= Supertrol-1

Display Type:

L= LCD

V= VFD

Input Type:

1= 110 VAC

2= 220 VAC

3= 12 VDC (10 to 14 VDC)

4= 24 VDC (14 to 28 VDC)

Relays:

A= 2 SPDT Relays

B= 4 SPDT Relays

Network Card:

0= None (STD)

2= RS485/Modbus (optional 2nd COM port)

Mounting:

P= Panel Mount ..... (see Fig. 1)

N= NEMA 4 Wall Mount ..... (see NEMAtrolST4X)

W= NEMA 12/13 Wall Mount w/ Clear Cover ..... (see Fig.2)

E= Explosion Proof (No Button Access) ..... (see XHVD 7/4)

X= Explosion Proof (with Button Access) ... (see XTROL 7/4)

Options:

TB= RS485 Terminal Block for Panel Mount Enclosure

ET= Extended Temperature  
-4°F to 131°F (-20°C to 55°C)

IM = Internal Modem

M = Modem Power Option

Accessories:

KEPS-KEP1-32  
KEP RS232 for SUPERtrol 1, SUPERtrol 1LE,  
SUPERtrol 2 and LEVELtrol 2 • 32 Bit OPC/DDE Server

KEPS-MBS32  
Supports RS485 for ST1, ST1LE, ST2,  
LT2, MRT, DRT & MB2 (Modbus RTU)

Modem Available, see MPP-2400 and MPP-2400N (requires M option)

Serial printer available, see P1000, P295

Ethernet Port Server available, see IEPS

RS-422/485 to RS-232 Communication Adaptor available, see CA285

Remote metering and data collection software available, see TROLlink

# BATCHtrol II

## Batch Controller With Two Stage Valve Control

### Features

- Start/Stop Buttons & Remote Inputs
- Separate 8 Digit K-Factors For Rate & Total
- Accepts Pulse or Analog Inputs
- Displays Rate, Total and Grand Total
- Security Lockout with Missing Pulse Detection
- Scaled Pulse Output
- Two Way RS232/422 Communications Option

- 2 Setpoints For Two Stage Valve Control
- NEMA 4X (IP65) Front Panel



### Description:

Featuring 8 digits of bright, .55 inch, alphanumeric display, the BATCHtrol II can accept up to 20,000 pulses per second of digital count. The analog input versions accept inputs, such as 4 to 20 mA or 1 to 5V. The standard unit has two separate, 8 digit, floating decimal, "K" factors to convert the inputs to meaningful total and rate data. An optional 16 point K-factor can linearize flow from non-linear meter outputs. The user, with the push of a button, can toggle back and forth to view the total of the batch, the rate of flow or the grand total of flow.

The BATCHtrol II may be thought of as two separate counters and a ratemeter. The "batching" counter counts to prewarn and preset numbers entered by the user and enables separate control outputs. The "totalizing" counter gives a cumulative reading or grand total. Finally, the ratemeter counts the number of pulses per second and, with its scaling feature, can provide gallons per minute or any other rate measurement without the totalizer losing counts. At any time, the user may view the total, the grand total or the rate while never interrupting the counting process.

Setup is done through the front panel and the menu driven software in the unit. Start-Stop control can be activated via the front panel buttons or remote inputs.

The unit operates from either 110 VAC/12 to 27 VDC, or optional 220 VAC/12 to 27 VDC. If AC power is used, two built-in regulated 12 VDC @ 100 mA power supplies are offered. They can be connected to provide +12 VDC and -12VDC or +24 VDC to drive external devices. CMOS Logic is used to provide high noise immunity and low power consumption with EEPROM to hold data a minimum of 10 years if power is interrupted.

Up to 15 addresses can be defined for the optional RS232 or RS422 communications port and units multi-dropped. The serial port can be used to set control points or access data.

### Specifications:

#### DISPLAY:

8 Digit, .55" High, 15 Segment, Red Orange, LED.

#### INPUT POWER: (Internally Fused)

A: 110 VAC  $\pm 15\%$  or 12 to 27 VDC

B: 220 VAC  $\pm 15\%$  or 12 to 27 VDC

#### CURRENT:

Maximum 280 mA DC or 5.3 VA (5.3W) at rated AC voltage.

#### OUTPUT POWER: (On AC powered units only):

+12 VDC at 100mA. Separate Isolated 12 VDC at 100mA to allow +12 VDC or +24 VDC regulated  $\pm 5\%$  worst case.

DC Outputs are supplied with resettable fuses.

### TEMPERATURE:

Operating: +32°F (0°C) to +130°F (+54°C).

Storage: -40°F (-40°C) to +200°F (+93°C).

ET: Extended Temperature -40° to 158°F (-40° to 70° C)

#### ET not available with analog inputs or outputs

**HUMIDITY:** 0-90% Noncondensing

**Listing:** CE Compliant

#### MEMORY:

EEPROM stores all program and total data for minimum of 10 years if power is lost.

#### PULSE INPUTS:

3A: Standard, High impedance pulse input.

Low: Open or 0 to 1 VDC

High: 3 to 30 VDC, 10K Ohm impedance 20 kHz max. input speed (min. on/off 25  $\mu$ sec.).

3B: Same as 3A but has 4.7K Ohm input pull up resistors to +5 VDC on input for pulsing with contact to ground or NPN open collector transistor.

#### ANALOG INPUTS:

The current loop or voltage input is converted to a highly linear 0 to 10 kHz frequency. This frequency can then be scaled by the 8 digit K-Factors to total or display rate in separate engineering units.

Accuracy over full temperature range:

Zero error: +0.175% full scale max.

Overall error: +0.5% full scale max.

5A/7A: 4-20mA, 250 Ohm impedance

5B/7B: 0-20mA, 250 Ohm impedance

5C/7C: 1-5 VDC, 15K Ohm impedance

5D/7D: 0-5 VDC, 15K Ohm impedance

5E/7E: 0-10 VDC, 15K Ohm impedance

6A: 4-20 mA, Square Law, 250 Ohm impedance

#### RESET:

Front push button: "CLR" resets displayed number and control output.

#### REMOTE START & STOP/RESET INPUTS:

A 4 to 30VDC positive pulse will activate these inputs. Pin 10 is the START input and when activated, the unit will "start." Pin 5 is the STOP/RESET input. When activated, the unit will "stop" (if unit is started and the batch is not complete). When the unit is stopped or the batch is complete, activating this input will reset the total. If pin 5 is held high (4 to 30VDC), the display will flash "STOPPED" and any start inputs will be inhibited. Stop always over-rides Start input.

**NOTE: The remote START input will not work with the type 7 input option (analog in & analog out) boards. All other features will work as described above.**

**These new features have not yet been added to the 16 point linearization BATCHtrol II version 12.0 .**

**FACTORED OUTPUT:**

The BATCHtrol II gives one pulse out for each increment in total. The open collector sinks 30 VDC maximum to 1 volt maximum at 100mA maximum. Output speed is user selectable (see table below). An internal buffer holds up to 10,000 pulses for output at the selected frequency before "DATALOST" flashes, indicating pulses are lost. If factored rate exceeds 7 digits "RFF..." flashes. These alarms indicated that speed has been exceeded.

Speed(HZ)	10	200	2000	20000
Min. on/off (msec)	47.5	2.0	0.2	0.013

**CONTROL OUTPUTS:**

(Each of two outputs)

1. NPN Transistor Version: (Optional)

The open collector sinks max. 250mA from 30 VDC when active. (When relay is used, 10 VDC is provided at transistor outputs through relay coil. If greater than 2mA is used, relay will remain energized. Applying greater than 10 VDC may destroy unit. Transistor will sink 100mA in "ON" state).

2. SPDT Relay Version:

10A 120/240 VAC or 28 VDC (Standard).

**ANALOG OUTPUT:**

Digital input or analog input (except Square Law) versions can be ordered with an analog output of the rate or total reading. User keys in the low and high settings at set-up.

Current Outputs:

A sinking driver generates a corresponding linear current through the external devices, updating with each update of the rate. Accuracy is ±.5% FS worst case. Compliance voltage must be 3 to 24 VDC, non inductive. (The BATCHtrol II can provide the DC source as long as the drop across all devices being driven does not exceed 21 V).

Voltage Outputs:

When the voltage out option is ordered, a controlled voltage output is located at terminal 3 and referenced to pin 12 (ground). Accuracy is .1% @ 20°C (max. drift .01%/C°).

**SECURITY:**

The BATCHtrol II has a missing pulse detector. The user selects the amount of time (1 to 99 sec.) that the unit will "wait" for input pulses. If the unit doesn't receive pulses within the selected time, the unit displays "SECURITY" and both relays drop out. (00 Disables the security feature; Entering the lockout code returns the unit to the run mode)

**PRESETS:**

The user may enter two numbers to set up the batch totalizer, Preset and Prewarn. The Prewarn is a number set a certain amount before the preset number. For instance, you may want one hundred gallons in a particular batch. You may also want a valve to close and slow down flow 25 gallons before the end. Your preset is 100, your prewarn is 25. When the start is activated, the relays energize simultaneously to start flow. When the totalizer reaches 75, the prewarn relay drops out. When the totalizer reaches 100 the preset relay drops out. The preset values can be viewed or changed via the menu (when stopped).

**K-FACTOR:**

In the standard unit a fixed K-Factor is used to convert the input pulses or frequency generated internally by the analog input to engineering units. The 8 digit K-Factor dividers, with decimal keyed into any position, allow easy direct entry of any K-Factor greater than 0.0001 to 99999999. Separate K-Factors may be entered for the total and rate section. Thus, you may batch and total in gallons and display rate in liters per hour.

**16 POINT LINEARIZATION:**

This variable K-factor option makes flow systems more accurate and often extends their usable range by allowing users to dial in different K-factors for different flow rates. It works with either pulse input or standard analog current loop or voltage input. It is recommended for flow meters whose K-factors change with different rates of flow. From 3 to 16 points of frequency from 0 to 10,000 Hz. and K-factors greater than .0001 to 999,999 are

dialled in at set up. The 16 point linearization option uses 8 digit floating math to interpolate between settings. Rate per second, per minute or per hour programmability eliminates the need to calculate separate K-factors for total and rate.

**TOTALIZER:**

Each of the total and grand total counters have 8 digits. In the set-up mode choose "R0" (reset to zero) for adding operation or "SP" (set to preset) for subtracting operation. While viewing the total the display can be made to flash the grand total by pressing "ENT". Activating "CLR" while the grand total is flashing, resets the grand totalizer.

**RATEMETER:**

Accurate to 5 1/2 digits (±1 display digit). The rate meter can be programmed to accept almost any number of pulses per unit of measurement, sample from 2 to 24 seconds maximum, and autorange up to 6 digits of significant information. The rate meter with a "K" factor of 1 displays the rate of pulses per second. Simply dial in the proper "K" factor to display in minutes, hours or other units of measurement. (See 16 Point Opt. Above) Press the "C" button while the unit is displaying the batch to display the rate; "R" is displayed on the left side of the display.

**WEIGHT:**

This feature is used to provide a weighted averaging of the rate data being received. Higher settings provide more averaging for a more stable display, derived from the equation:

$$\frac{(\text{Old Data} \times \text{"Weight"}) + \text{New Data}}{(\text{"Weight"} + 1)}$$

**LOCKOUT:**

Unauthorized front panel changes can be prevented by entering a user selected four digit code.

**OUTCARD:**

RS232 or RS422 serial two way communication options are available. Up to 15 units can be linked together and addressed separately to transmit unit status or accept new set points in the standard ASCII format. Baud rates of 300, 600,1200,2400 4800 or 9600 as well as choice of odd, even, space or mark parity can be selected by keypad control.

**Termination:**

- 1 • NOT USED
- 2 • SCALED OUTPUT (OPEN COLLECTOR)
- 3 • ANALOG OUTPUT (SINK)
- 4 • INPUT (PULSE/ANALOG)
- 5 • STOP / RESET INPUT
- 6 • NOT USED
- 7 • NOT USED
- 8 • NOT USED
- 9 • NOT USED
- 10 • START INPUT
- 11 • NO CONNECTION
- 12 • GROUND (-DC)
- 13 • 12 VOLTS OUT
- 14 • + DC POWER IN (12 to 27 VDC)
- 15 • ISOLATED -12 VOLTS OUT
- 16 • ISOLATED +12 VOLTS OUT
- 17 • AC INPUT
- 18 • AC INPUT
- 19 • PREWARN TRANSISTOR
- 20 • PRESET TRANSISTOR

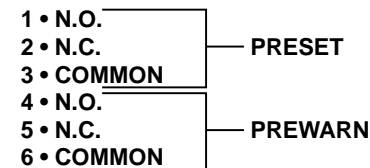

**Typical Hookup:**

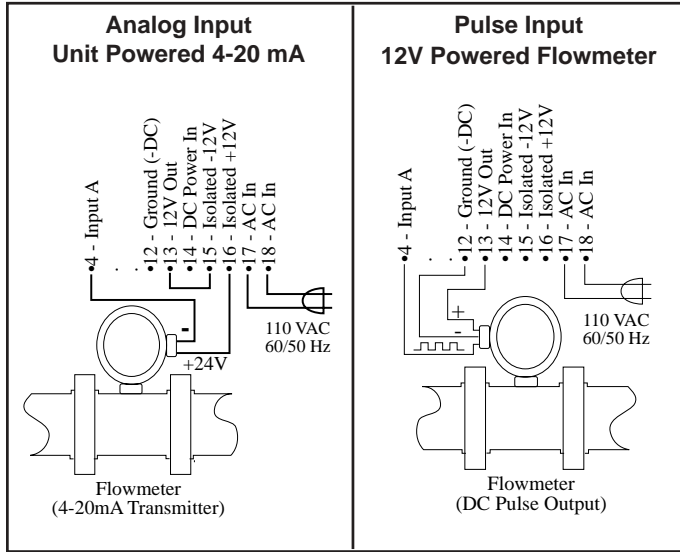

**Dimensions:**

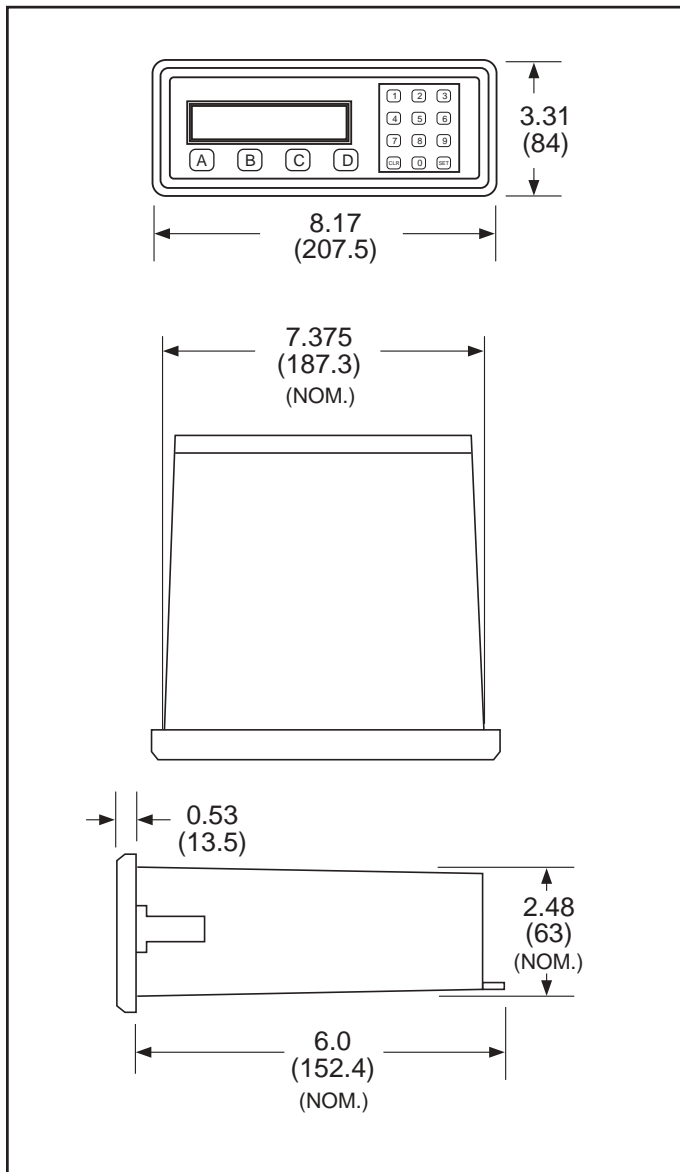

**Ordering Information**

**Example**    BT28    A    3A    2    A    1 3

**Series:** \_\_\_\_\_  
Batchrol II

**Operating Voltage:** \_\_\_\_\_  
A: 110 VAC ±15% or 12 to 27 VDC  
B: 220 VAC ±15% or 12 to 27 VDC

**Control Inputs:** \_\_\_\_\_  
\* 3A: STD Pulse 3-30 VDC 20 kHz Max.  
\* 3B: As 3A, with 4.7 KΩ pull up resistors

5A: 4-20 mA  
5B: 0-20 mA  
5C: 1-5 VDC  
5D: 0-5 VDC  
5E: 0-10 VDC  
6A: 4-20 mA Square Law  
7A: 4-20mA in, 4-20mA out  
7B: 0-20mA in, 4-20mA out  
7C: 1-5VDC in, 4-20mA out  
7D: 0-5VDC in, 4-20mA out  
7E: 0-10VDC in, 4-20mA out

**For Other Outputs:**  
Add X for 0-20mA out  
Add Y for 0-5V out  
Add Z for 0-10V out

**Control Outputs:** \_\_\_\_\_  
1: Open Collector  
2: SPDT Relay 10A (standard)

**Input Speed:** \_\_\_\_\_  
\* A: 0-40 CPS (Inputs 3A, 3B)  
\* C: 0-400 CPS (Inputs 3A, 3B)  
\* E: 0-20K CPS (Inputs 3A, 3B)  
\* K: Inputs 5A-5E, 6A, 7A-7E  
\* Dip switch selectable,  
all units can be field modified easily.

**Options:** (Multiple Options Available) \_\_\_\_\_  
1: RS232 Serial Interface  
2: RS422 Serial Interface  
3: 4-20 mA Output (Input 3A or 3B only)  
3X: 0-20 mA Output (Input 3A or 3B only)  
3Y: 0-5VDC Output (Input 3A or 3B only)  
3Z: 0-10VDC Output (Input 3A or 3B only)  
4: 16 Point Linearization Opt.  
CSA: CSA Approved Unit (pending) ..... Consult Factory  
ET: Extended Temperature:  
-40° to 158°F (-40° to 70° C)

**ET not available with analog inputs or outputs**

**Accessories:**  
FLEXCOVER #36120  
XTROL7/4- Explosion proof housing  
NEMA 4X wall mount enclosure available, see NEMATROL  
Serial printer available, see P1000, P295  
Ethernet Port Server available, see IEPS  
RS-422/485 to RS-232 Communication Adaptor available, see CA285



# Flow Computer Tutorial

**What is a flow computer?** A special purpose device which computes a corrected flow based on information derived from raw input signals and stored sensor and fluid properties information

**What are the typical applications requiring a flow computer?** Computation of Heat Flow, Mass Flow, Corrected Volume Flow typically require a flow computer. In addition, many flow sensors require linearization to improve accuracy. The flow computer is also used for data logging, communication, remote metering, alarming and control functions. In many cases a flow computer may replace some of the functionality of a small PLC in your application.

**What are typical uses of flow computers?** The figures and equations below illustrate a number of the common applications for flow computers.

**Where do the equations come from which are solved by the flow computer?** All flow measurement sensors have basic mathematical expressions which describe how they relate the measured input signal to a flow measurement. Often there are a number of such expressions for each flowmeter type which range from the simple to those which include additional second order effects. In addition, there are basic equations from thermodynamics and industry standard equations which are utilized in liquid, gas, steam, and heat.

**How can you enhance the accuracy of flow meters?** A flow computer often offers a variety of performance enhancement functions. These range from simple square root functions, to more elaborate linearization tables applicable to that flowmeter type. In addition, the flow computer can correct for changes in physical dimensions of the flowmeter with temperature and for the effects of changes in fluid properties of the material being measured in some cases.

**How are fluid properties determined?** Fluid properties are stored within the flow computer. Properties are then computed as a function of measured fluid temperature and/or pressure. Density and viscosity are among the most commonly computed fluid properties.

**What types of flowmeters typically use flow computers?** The most common types used in conjunction with flow computers are turbine, vortex, positive displacement, orifice and similar types, magnetic flowmeters, and a variety of special flowmeter types. Flow computers are often used with other types when the application calls for local information display, data communications, control, alarm, and data logging functions.

**What other factors should be considered?** Flexibility in use of flow computation and use of inputs and outputs, signal input resolution and accuracy, isolation, 24VDC to power transmitters, networking, communications software and accessories, printing, data logging and remote metering support. Approvals may also be required. Instrument setup software is also of value. Application support from the manufacturer is also important.

## Applications & Equations

### Steam Mass & Steam Heat Illustration

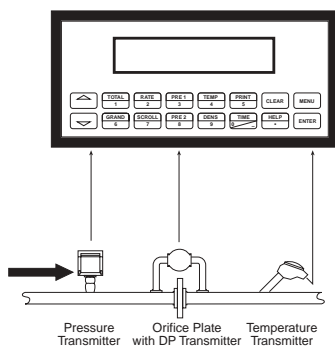

#### Calculations

##### Mass Flow

$$\text{Mass Flow} = \text{volume flow} \cdot \text{density} (T, p)$$

##### Heat Flow

$$\text{Heat Flow} = \text{Volume flow} \cdot \text{density} (T, p) \cdot \text{Sp. Enthalpy of steam} (T, p)$$

### Steam Net Heat Illustration

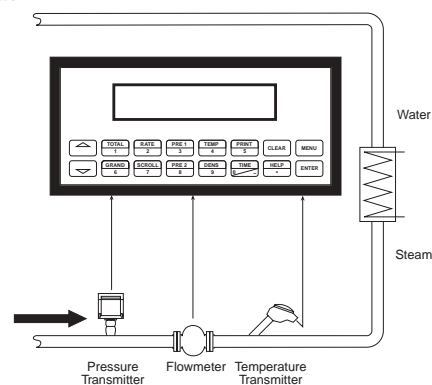

#### Calculations

##### Net Heat Flow

$$\text{Net Heat Flow} = \text{Volume flow} \cdot \text{density} (T, p) \cdot [E_D (T, p) - E_W (T_{S(p)})]$$

- $E_D$  = Specific enthalpy of steam
- $E_W$  = Specific enthalpy of water
- $T_{S(p)}$  = Calculated condensation temperature (= saturated steam temperature for supply pressure)

**Steam Delta Heat Illustration**

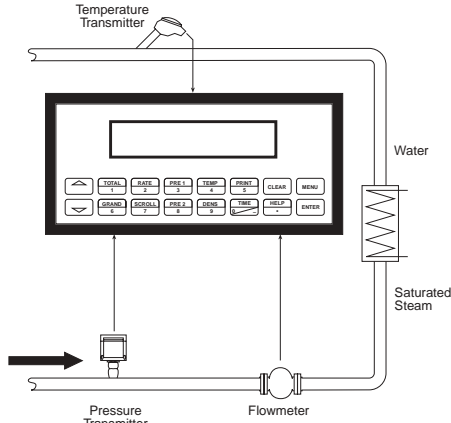

**Calculations**

**Delta Heat Flow**

Net Heat Flow =  
Volume flow • density (ρ) • [E<sub>D</sub> (p) – E<sub>w</sub> (T)]

- E<sub>D</sub> = Specific enthalpy of steam
- E<sub>w</sub> = Specific enthalpy of water

**Liquid Corrected Volume Flow Mass Flow Combustion Heat Flow Illustration**

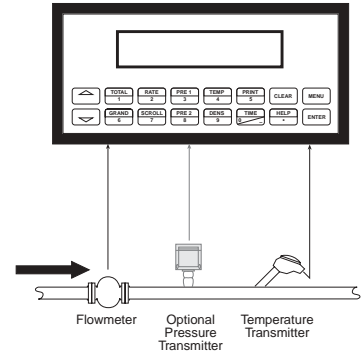

**Calculations**

**Corrected Volume Flow**

Corrected Volume Flow = vol. flow • (1 - α • (T<sub>f</sub>-T<sub>ref</sub>))<sup>2</sup>

**Mass Flow**

Mass Flow =  
volume flow • (1-α • (T-T<sub>ref</sub>))<sup>2</sup> • ref. density

**Heat Flow**

Heat Flow =  
C • volume flow • (1-α • (T-T<sub>ref</sub>))<sup>2</sup> • ref. density

- α = Thermal expansion coefficient • 10<sup>-6</sup>
- C = Specific combustion heat

**Gas**

**Corrected Volume Flow Combustion Heat Flow Mass Flow Illustration**

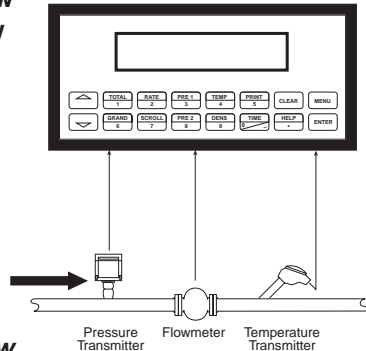

**Calculations**

**Corrected Volume Flow**

Corrected Volume Flow =  
Volume Flow • P/P<sub>ref</sub> • T<sub>ref</sub>/T • Z<sub>ref</sub>/Z

**Combustion Heat Flow**

Combustion Energy =  
C • ρ<sub>ref</sub> • Q • P/P<sub>ref</sub> • T<sub>ref</sub>/T • Z<sub>ref</sub>/Z

**Mass Flow**

Mass Flow =  
Actual Volume Flow • ρ<sub>ref</sub> • P/P<sub>ref</sub> • T<sub>ref</sub>/T • Z<sub>ref</sub>/Z

- ρ<sub>ref</sub> = Reference density
- T<sub>ref</sub> = Reference temperature
- P<sub>ref</sub> = Reference pressure
- Z<sub>ref</sub> = Reference Z-factor
- C = Specific combustion heat
- Q = Volume flow

**Liquid Delta Heat Illustration**

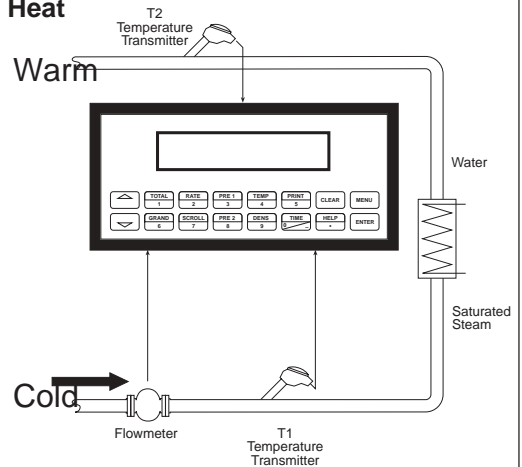

**Calculations**

**Water**

Heat = Volume Flow • ρ(T<sub>1</sub>) • [h(T<sub>2</sub>) – h(T<sub>1</sub>)]

**Other heat carrying liquids**

Heat = C • volume flow • (1-α • (T<sub>1</sub>-T<sub>ref</sub>))<sup>2</sup> • ρ<sub>ref</sub> • (T<sub>2</sub> - T<sub>1</sub>)

- α = Thermal expansion coefficient • 10<sup>-6</sup>
- C = Mean specific heat
- ρ(T<sub>1</sub>) = Density of water at temperature T<sub>1</sub>
- h(T<sub>1</sub>) = Specific enthalpy of water at temperature T<sub>1</sub>
- h(T<sub>2</sub>) = Specific enthalpy of water at temperature T<sub>2</sub>
- ρ<sub>ref</sub> = Reference density
- T<sub>ref</sub> = Reference temperature

# SUPERtrol II

## Multi-Function Flow Computer

- "EZ Setup"- Guided Setup for First Time Users
- Liquid, Gas, Steam and Heat Flow Equations
- Utility Metering
- Menu Selectable Hardware & Software Features
- Internal Data Logging Option
- Isolated Pulse and Analog Outputs Standard
- RS-232 Port Standard, RS-485 Optional Windows™ Setup Software
- NX19 Gas Equations, Stacked DP Transmitters
- DDE Server & HMI Software Available
- Remote Metering by Wireless or Modem and TROLlink Remote Metering Software Available
- NEW! - Attractive Wall Mount Enclosure

### Description:

The SUPERtrol II Flow Computer satisfies the instrument requirements for a variety of flowmeter types in liquid, gas, steam and heat applications. Multiple flow equations are available in a single instrument with many advanced features.

The alphanumeric display offers measured parameters in easy to understand format. Manual access to measurements and display scrolling is supported

The versatility of the Flow Computer permits a wide measure of versatility within the instrument package. The various hardware inputs and outputs can be "soft" assigned to meet a variety of common application needs. The user "soft selects" the usage of each input/output while configuring the instrument. Consider the following illustrative examples.

The isolated analog output can be chosen to follow the volume flow, corrected volume flow, mass flow, temperature, pressure, or density by means of a menu selection. Most hardware features are assignable by this method.

The user can assign the standard RS-232 Serial Port for external data logging, transaction printing, or for connection to a modem for remote meter reading.

A Service or Test mode is provided to assist the user during start-up system check out by monitoring inputs and exercising outputs. The system setup can also be printed.

### Specifications:

#### Environmental

Operating Temperature: 0 to +50 C  
Storage Temperature: -40 to +85 C  
Humidity : 0-95% Non-condensing  
Materials: UL, CSA, VDE approved

#### Display

Type: 2 lines of 20 characters  
Types: Backlit LCD and VFD ordering options  
Character Size: 0.3" nominal  
User selectable label descriptors and units of measure



### Keypad

Keypad Type: Membrane Keypad  
Keypad Rating: Sealed to Nema 4  
Number of keys: 16

### Enclosure

Enclosure Options: Panel, Wall, Explosion Proof  
Size: See Dimensions  
Depth behind panel: 6.5" including mating connector  
Type: DIN  
Materials: Plastic, UL94V-0, Flame retardant  
Bezel: Textured per matt finish

### Power Input

The factory equipped power option is internally fused. An internal line to line filter capacitor is provided for added transient suppression. MOV protection for surge transient is also supported

Universal AC Power: 85 to 276 Vrms, 50/60 Hz  
DC Power Option: 24 VDC (16 to 48 VDC)

### Power Consumption

AC Power: 6.5 V/A (6.5W)  
DC Power: 300 mA max.

### Flow Meter Types:

Linear: Vortex, Turbine, Positive Displacement, Magnetic, GilFlo and others  
Square Law: Orifice, Venturi, Nozzle, V-Cone, Wedge, Averaging Pitot, Target and others  
Multi-Point Linearization: May be used with all flowmeter types. Including: 16 point, UVC and dynamic compensation.

### Flow Inputs:

#### Analog Input:

Accuracy: 0.02% FS at 20° C

#### Ranges

Voltage: 0-10 VDC, 0-5 VDC, 1-5 VDC

Current: 4-20 mA, 0-20 mA,

4-20 mA stacked, 0-20 mA stacked

Basic Measurement Resolution: 16 bit

Update Rate: 4 updates/sec

Automatic Fault detection: Signal over/under-range, Current Loop Broken

Calibration: Operator assisted learn mode

Extended calibration: Learns Zero and Full Scale of each range

#### Fault Protection:

Fast Transient: 500 V Protection (capacitive clamp)

Reverse Polarity: No ill effects

Over-Voltage Limit: 50 VDC Over voltage protection

Over-Current Protection: Internally current limited protected to 24VDC

**Pulse Inputs:**

Number of Flow Inputs: one  
 Input Impedance: 10 k Ω nominal  
 Trigger Level: (menu selectable)  
     High Level Input  
         Logic On: 2.5 to 30 VDC  
         Logic Off: 0 to 2 VDC  
     Low Level Input (mag pickup)  
         Selectable sensitivity: 10 mV and 100 mV  
 Minimum Count Speed: 0.25 Hz (to maintain rate display)  
 Maximum Count Speed: Selectable: 0 to 50 kHz  
 Overvoltage Protection: 50 VDC

**Temperature, Pressure, Density Inputs**

The compensation inputs usage are menu selectable for temperature, temperature 2, pressure, density or not used.

Calibration: Operator assisted learn mode  
 Operation: Ratiometric  
 Accuracy: 0.02% FS at 20° C  
 Basic Measurement Resolution: 16 bit  
 Update Rate: 2 updates/sec minimum  
 Automatic Fault detection:  
     Signal Over-range/under-range  
     Current Loop Broken  
     RTD short  
     RTD open  
     Reverse Polarity: No ill effects  
     Over-Current Limit  
         (current input) Internally limited to protect input to 24 VDC

Available Input Ranges  
 Current: 4-20 mA, 0-20 mA  
 Resistance: 100 Ohms DIN RTD

100 Ohm DIN RTD (DIN 43-760, BS 1904):  
 Three Wire Lead Compensation  
 Internal RTD linearization learns ice point resistance  
 1 mA Excitation current with reverse polarity protection  
 Temperature Resolution: 0.1°C

**Stored Information (ROM)**

Steam Tables (saturated & superheated),  
 Fluid Properties: Water, Air, Natural Gas, A Variety of User Entered Industrial Fluids or Generic

**User Entered Stored Information (EEPROM / Nonvolatile RAM)**

Transmitter Ranges, Signal Types  
 Fluid Properties  
     (reference density, expansion factor, specific heat, viscosity, isentropic exponent, combustion heating value, Z factor)  
 Units Selections (English/Metric)  
 Language Translations (optional)

**Excitation Voltage**

24 VDC @ 100 mA (fault protected with self resetting fuse)

**Relay Outputs**

The relay outputs usage is menu assignable to (Individually for each relay) Hi/Lo Rate Alarm, Hi/Lo Temperature Alarm, Hi/Lo Pressure Alarm, Pulse Output (pulse options), Wet Steam or General purpose warning (security).

Number of relays: 2 (3 optional)  
 Contact Style: Form C contacts  
 Contact Ratings: 240 V, 5 amp

**Analog Outputs**

The analog outputs are menu assignable to correspond to the Uncompensated Volume Rate, Corrected Volume Rate, Mass Rate, Heat Rate, Temperature, Density, or Pressure.

Number of Outputs: 2  
 Type: Isolated Current Sourcing (shared common)  
 Available Ranges: 0-20 mA, 4-20 mA (menu selectable)  
 Resolution: 16 bit  
 Accuracy: 0.05% FS at 20 Degrees C  
 Update Rate: 5 updates/sec  
 Temperature Drift: Less than 200 ppm/C  
 Maximum Load: 1000 ohms  
 Compliance Effect: Less than .05% Span  
 60 Hz rejection: 40 dB minimum  
 EMI: No effect at 3 V/M  
 Calibration: Operator assisted Learn Mode  
 Averaging: User entry of DSP Averaging constant to cause a smooth control action

**Listing:** CE Compliant, UL/C-UL Pending

**Serial Communication**

The serial port can be used for printing, datalogging, modem connection, two way paging and communication with a computer.

RS-232:  
 Device ID: 01-99  
 Baud Rates: 300, 600, 1200, 2400, 4800, 9600, 19200  
 Parity: None, Odd, Even  
 Handshaking: None, Software, Hardware  
 Print Setup: Configurable print list and formatting  
 RS-485: (optional 2nd COM port)  
 Device ID: 01-247  
 Baud Rates: 300, 600, 1200, 2400, 4800, 9600, 19200  
 Parity: None, Odd, Even  
 Protocol: Modbus RTU (Half Duplex)

**Data Logging**

The data logger captures print list information to internal storage for approximately 5000 transactions. This information can be used for later uploading or printing. Storage format is selectable for Comma-Carriage Return or Printer formats.

**Isolated Pulse output**

The isolated pulse output is menu assignable to Uncompensated Volume Total, Compensated Volume Total, Heat Total or Mass Total.

Pulse Output Form (menu selectable): Open Collector NPN or 24 VDC voltage pulse  
 Nominal On Voltage: 24 VDC  
 Maximum Sink Current: 25 mA  
 Maximum Source Current: 25 mA  
 Maximum Off Voltage: 30 VDC  
 Saturation Voltage: 0.4 VDC  
 Pulse Duration: User selectable  
 Pulse output buffer: 8 bit  
 Fault Protection  
     Reverse polarity:  
         Shunt Diodes  
     Over-current Protected  
     Over-voltage Protected

**Real Time Clock**

The Flow Computer is equipped with a pseudo nonvolatile real time clock with display of time and date.

Format:  
 24 hour format for time  
 Day, Month, Year for date

**Fig. 1: Standard Dimensions**

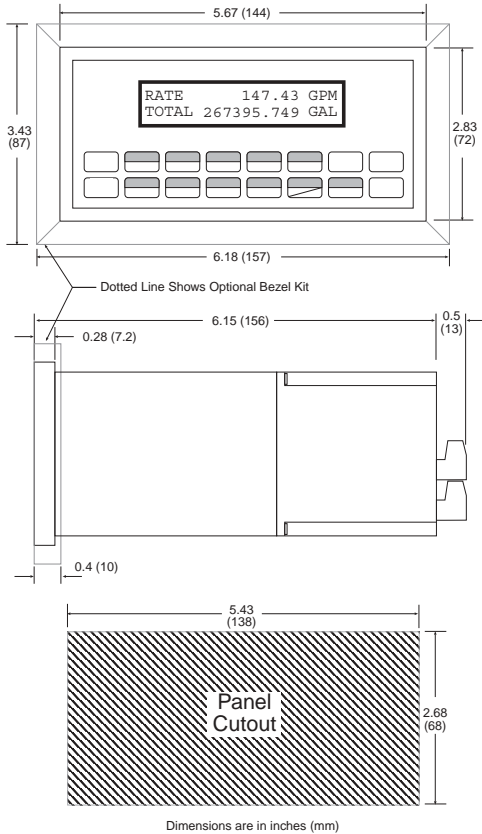

**Fig. 2: Wall Mount ("W" mounting option) Dimensions**

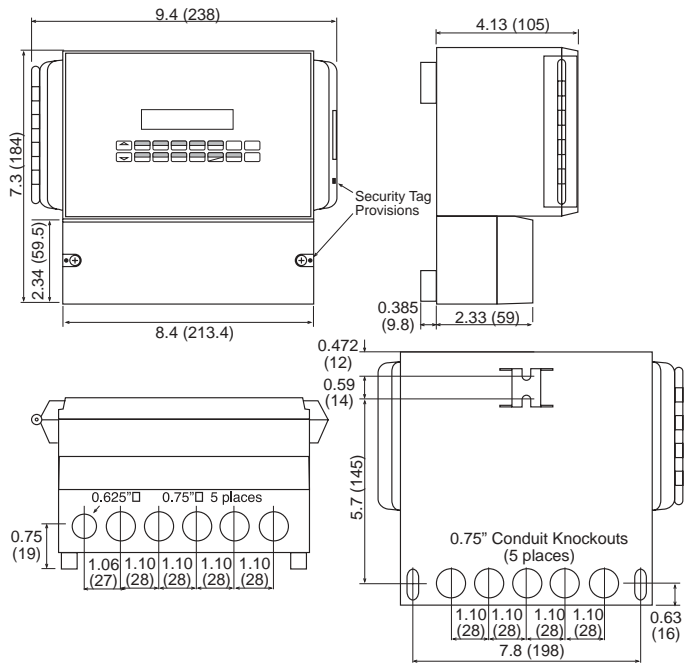

**Terminal Designations**

1	DC OUTPUT PULSE IN	2	V/in (+)	3	lin (+)	4	COMMON	5	RTD EXCIT (+)	6	RTD SENS (+)	7	RTD SENS (-)	8	DC OUTPUT	9	RTD EXCIT (+)	10	RTD SENS (+)	11	RTD SENS (-)	12	PULSE OUTPUT (+)	13	PULSE OUTPUT (-)	14	ANALOG OUTPUT 1 (+)	15	ANALOG OUTPUT 2 (+)	16	ANALOG OUTPUT COMMON (-)	17	NO	18	COM RLY1	19	NC	20	NC	21	COM RLY2	22	NO	23	AC LINE	24	AC LINE	POWER IN DC (+)	POWER IN DC (-)
---	--------------------	---	----------	---	---------	---	--------	---	---------------	---	--------------	---	--------------	---	-----------	---	---------------	----	--------------	----	--------------	----	------------------	----	------------------	----	---------------------	----	---------------------	----	--------------------------	----	----	----	----------	----	----	----	----	----	----------	----	----	----	---------	----	---------	-----------------	-----------------

**Terminal Layout**

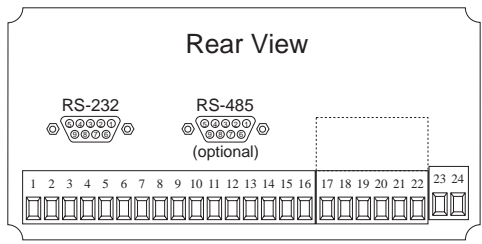

**Ordering Information**

**Example** ST2 L 1 0 P M

**Series:** ST2 = Flow Computer

**Display Type:** L = LCD, V = VFD

**Input Power:** 1 = 85 to 276 VAC, 3 = 24 VDC (16 to 48 VDC)

**Network Card:** 0 = None, 1 = RS485/Modbus (optional 2nd COM port)

**Mounting:** P = Panel Mount, N = NEMA 4 Wall Mount, W = NEMA 12/13 Wall Mount w/ Clear Cover, E = Explosion Proof (No Button Access), X = Explosion Proof (with Button Access)

**Options:** 1 = Peak Demand, 2 = AGA NX-19 calculation for natural gas, 3 = Three Relays, 4 = Stacked DP option, 5 = Datalogger option (consult factory), 6 = Stack Emissions Controller option, 7 = Manifold Flowmeter Controller option, 9 = 3 Relay Super Chip (options 1, 2, 4, 6,7), 10 = 2 Relay Super Chip (options 1, 2, 4, 6,7), 13 = Superchip; 2 relay, Positive heat only, 14 = Superchip; 3 relay, Positive heat only, ET = Extended Temperature; -4°F to 131°F (-20°C to 55°C), IM = Internal Modem, M = Modem Power Option, TB = RS485 Terminal Block for Panel Mount Enclosure, TU = Translation Utility Disk

**Accessories:**  
 KEPS-KEP1-32 = KEP RS232 DDE server for SUPERtrol.  
 KEPS-MBS32 = Modbus RTU OPC/DDE server  
 SUPERtrol 2 and LEVELtrol 2 \* 32 Bit DDE Server  
 Modem Available, see MPP-2400 and MPP-2400N (requires M option)  
 Two Way Pager Available, see MPP-TWP (requires M option)  
 Serial printer available, see P1000, P295  
 Ethernet Port Server available, see IEPS  
 RS-422/485 to RS-232 Communication Adaptor available, see CA285  
 Remote metering and data collection software available, see TROLlink

Flow Instruments  
FLOW COMPUTERS

# MS-748

## Rugged, Field Mount Multi-Function Flow Computer

- "EZ Setup"- Guided Setup for First Time Users
- Liquid, Gas, Steam and Heat Flow Equations
- Utility Metering
- Menu Selectable Hardware & Software Features
- Internal Data Logging Option
- Isolated Pulse and Analog Outputs Standard
- RS-232 Port Standard, RS-485 Optional  
Windows™ Setup Software
- NX19 Gas Equations, Stacked DP Transmitters
- DDE Server & HMI Software Available
- Remote Metering by Wireless or Modem and  
TROLlink Remote Metering Software Available
- NEW! - Attractive, Rugged, Field Mount  
Enclosure



### Description:

The MS-748 Flow Computer satisfies the instrument requirements for a variety of flowmeter types in liquid, gas, steam and heat applications. Multiple flow equations are available in a single instrument with many advanced features. The unit is provided in a rugged enclosure.

The alphanumeric display offers measured parameters in easy to understand format. Manual access to measurements and display scrolling is supported

The versatility of the Flow Computer permits a wide measure of versatility within the instrument package. The various hardware inputs and outputs can be "soft" assigned to meet a variety of common application needs. The user "soft selects" the usage of each input/output while configuring the instrument. Consider the following illustrative examples.

The isolated analog output can be chosen to follow the volume flow, corrected volume flow, mass flow, temperature, pressure, or density by means of a menu selection. Most hardware features are assignable by this method.

The user can assign the standard RS-232 Serial Port for external data logging, transaction printing, or for connection to a modem or two way pager transceiver for remote meter reading.

A Service or Test mode is provided to assist the user during start-up system check out by monitoring inputs and exercising outputs. The system setup can also be printed.

### Specifications:

#### Environmental

Operating Temperature: -20 to 55 C  
Storage Temperature: -40 to +85 C  
Humidity : 0-95% Non-condensing  
Materials: UL, CSA, VDE approved

#### Display

Type: 2 lines of 20 characters  
Types: Backlit LCD and VFD ordering options  
Character Size: 0.3" nominal  
User selectable label descriptors and units of measure

#### Keypad

Keypad Type: Membrane Keypad  
Keypad Rating: Sealed to Nema 4  
Number of keys: 16

#### Enclosure

Size: See Dimensions  
Materials: Aluminum, UL94V-0 Keypad  
Enclosure Rating: NEMA 4X  
Provisions for sealing unit

## Power Input

The factory equipped power option is internally fused. An internal line to line filter capacitor is provided for added transient suppression. MOV protection for surge transient is also supported

Universal AC Power: 85 to 276 Vrms, 50/60 Hz

DC Power Option: 24 VDC (16 to 48 VDC)

Power Consumption

AC Power: 6.5 V/A (6.5W)

DC Power: 300 mA max.

## Flow Meter Types:

Linear: Vortex, Turbine, Positive Displacement, Magnetic, GilFlo and others

Square Law: Orifice, Venturi, Nozzle, V-Cone, Wedge, Averaging Pitot, Target and others

Multi-Point Linearization: May be used with all flowmeter types. Including: 16 point, UVC and dynamic compensation.

## Flow Inputs:

### Analog Input:

Accuracy: 0.01% FS at 20° C

Ranges

Voltage: 0-10 VDC, 0-5 VDC, 1-5 VDC

Current: 4-20 mA, 0-20 mA,  
4-20 mA stacked, 0-20 mA stacked

Basic Measurement Resolution: 16 bit

Update Rate: 4 updates/sec

Automatic Fault detection: Signal over/under-range,  
Current Loop Broken

Calibration: Operator assisted learn mode

Extended calibration: Learns Zero and Full Scale of each range

Fault Protection:

Fast Transient: 500 V Protection (capacitive clamp)

Reverse Polarity: No ill effects

Over-Voltage Limit: 50 VDC Over voltage protection

Over-Current Protection: Internally current limited protected to 24VDC

### Pulse Inputs:

Number of Flow Inputs: one

Input Impedance: 10 k  $\Omega$  nominal

Trigger Level: (menu selectable)

High Level Input

Logic On: 2.5 to 30 VDC

Logic Off: 0 to 2 VDC

Low Level Input (mag pickup)

Selectable sensitivity: 10 mV and 100 mV

Minimum Count Speed: 0.25 Hz (to maintain rate display)

Maximum Count Speed: Selectable: 0 to 50 kHz

Overvoltage Protection: 50 VDC

## Temperature, Pressure, Density Inputs

The compensation inputs usage are menu selectable for temperature, temperature 2, pressure, density or not used.

Calibration: Operator assisted learn mode

Operation: Ratiometric

Accuracy: 0.02% FS at 20° C

Basic Measurement Resolution: 16 bit

Update Rate: 2 updates/sec minimum

Automatic Fault detection:

Signal Over-range/under-range

Current Loop Broken

RTD short

RTD open

Reverse Polarity: No ill effects

Over-Current Limit

(current input) Internally limited to protect input to 24 VDC

Available Input Ranges

Current: 4-20 mA, 0-20 mA

Resistance: 100 Ohms DIN RTD

100 Ohm DIN RTD (DIN 43-760, BS 1904):

Three Wire Lead Compensation

Internal RTD linearization learns ice point resistance

1 mA Excitation current with reverse polarity protection

Temperature Resolution: 0.1°C

## Stored Information (ROM)

Steam Tables (saturated & superheated),

Fluid Properties: Water, Air, Natural Gas and Other Common Fluids or Generic

## User Entered Stored Information (EEPROM / Nonvolatile RAM)

Transmitter Ranges, Signal Types

Fluid Properties

(reference density, expansion factor, specific heat, viscosity, isentropic exponent, combustion heating value, Z factor)

Units Selections (English/Metric)

Language Translations (optional)

## Excitation Voltage

24 VDC @ 100 mA (fault protected with self resetting fuse)

**Relay Outputs**

The relay outputs usage is menu assignable to (Individually for each relay) Hi/Lo Rate Alarm, Hi/Lo Temperature Alarm, Hi/Lo Pressure Alarm, Pulse Output (pulse options), Wet Steam or General purpose warning (security).

Number of relays: 2 (3 optional)  
Contact Style: Form C contacts  
Contact Ratings: 240 V, 5 amp

**Analog Outputs**

The analog outputs are menu assignable to correspond to the Uncompensated Volume Rate, Corrected Volume Rate, Mass Rate, Heat Rate, Temperature, Density, or Pressure.

Number of Outputs: 2  
Type: Isolated Current Sourcing (shared common)  
Available Ranges: 0-20 mA, 4-20 mA (menu selectable)  
Resolution: 16 bit  
Accuracy: 0.05% FS at 20 Degrees C  
Update Rate: 5 updates/sec  
Temperature Drift: Less than 200 ppm/C  
Maximum Load: 1000 ohms  
Compliance Effect: Less than .05% Span  
60 Hz rejection: 40 dB minimum  
EMI: No effect at 3 V/M  
Calibration: Operator assisted Learn Mode  
Averaging: User entry of DSP Averaging constant to cause a smooth control action

**Listing:** CE Compliant, UL/CSA Pending

**Serial Communication**

The RS-232 serial port can be used for printing, datalogging, modem connection, two way paging and communication with a computer.

RS-232:  
Device ID: 01-99  
Baud Rates: 300, 600, 1200, 2400, 4800, 9600, 19200  
Parity: None, Odd, Even  
Handshaking: None, Software, Hardware  
Print Setup: Configurable print list and formatting  
RS-485: (optional 2nd COM port)  
Device ID: 01-247  
Baud Rates: 300, 600, 1200, 2400, 4800, 9600, 19200  
Parity: None, Odd, Even  
Protocol: Modbus RTU (Half Duplex)

**Data Logging**

The data logger captures print list information to internal storage for approximately 5000 transactions. This information can be used for later uploading or printing. Storage format is selectable for Comma-Carriage Return or Printer formats.

**Isolated Pulse output**

The isolated pulse output is menu assignable to Uncompensated Volume Total, Compensated Volume Total, Heat Total or Mass Total.

Pulse Output Form (menu selectable): Open Collector NPN or 24 VDC voltage pulse  
Nominal On Voltage: 24 VDC  
Maximum Sink Current: 25 mA  
Maximum Source Current: 25 mA  
Maximum Off Voltage: 30 VDC  
Saturation Voltage: 0.4 VDC  
Pulse Duration: User selectable  
Pulse output buffer: 8 bit  
Fault Protection  
Reverse polarity:  
Shunt Diodes  
Over-current Protected  
Over-voltage Protected

**Real Time Clock**

The Flow Computer is equipped with a pseudo nonvolatile real time clock with display of time and date.  
Format:  
24 hour format for time  
Day, Month, Year for date



## Dimensions

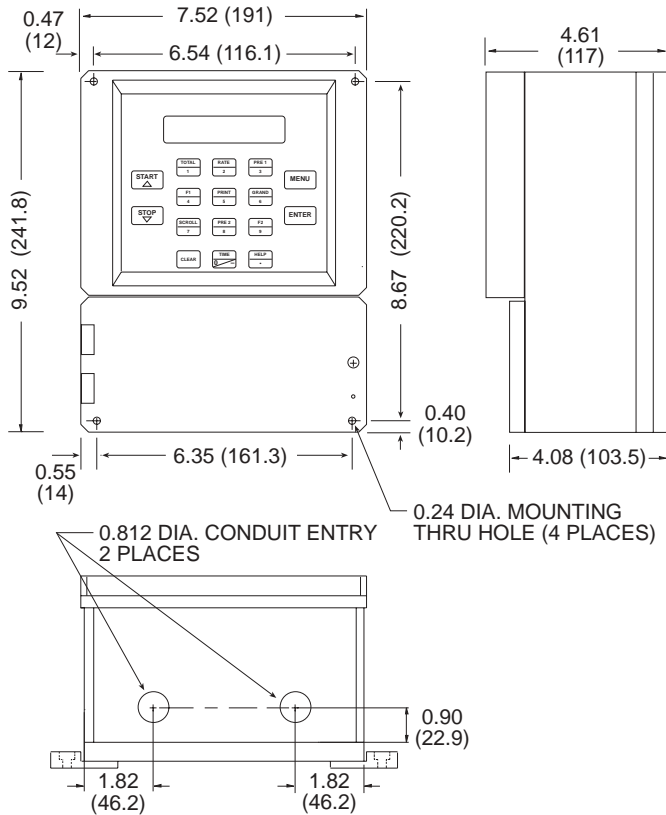

### Optional Mounting Bracket (MB)

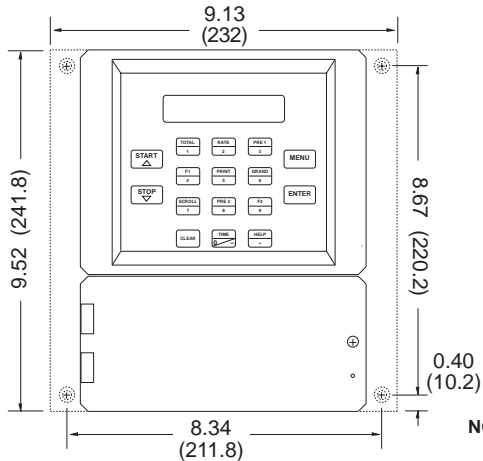

NOTE: All dimensions are in inches (mm)

## Terminal Designations

1	DC OUTPUT	FLOW	
2	PULSE IN	IN	
3	-----		
4	COMMON		
5	RTD EXCIT (+)	TEMPERATURE	
6	RTD SENS (+)	IN	
7	RTD SENS (-)	IN (+)	
8	DC OUTPUT		
9	RTD EXCIT (+)	PRESSURE	
10	RTD SENS (+)	(TEMP 2)	
11	RTD SENS (-)	IN	
12	PULSE OUTPUT (+)		
13	PULSE OUTPUT (-)		
14	ANALOG OUTPUT 1 (+)		
15	ANALOG OUTPUT 2 (+)		
16	ANALOG OUTPUT COMMON (-)		
17	NO		
18	COM RLY1		
19	NC		
20	NC		
21	COM RLY2		
22	NO		
23	AC LINE	DC (+)	POWER IN
24	AC LINE	DC (-)	

## Ordering Information

<b>Example</b>	<b>MS-748</b>	<b>L</b>	<b>1</b>	<b>0</b>	<b>V</b>	<b>MB</b>
<b>Series:</b>	MS-748 = Flow Computer					
<b>Display Type:</b>	L = LCD V = VFD					
<b>Input Power:</b>	1 = 85 to 276 VAC 3 = 24 VDC (16 to 48 VDC)					
<b>Network Card:</b>	0 = None 1 = RS485/Modbus (optional 2nd COM port)					
<b>Mounting:</b>	V = Field, Skid, Vehicle Mount					
<b>Options:</b>	1 = Peak Demand 2 = AGA NX-19 calculation for natural gas 3 = Three Relays 4 = Stacked DP option 5 = Datalogger option (consult factory) 6 = Stack Emissions Controller option 7 = Manifold Flowmeter Controller option 9 = 3 Relay Super Chip (options 1, 2, 4, 6,7) 10 = 2 Relay Super Chip (options 1, 2, 4, 6,7) 13 = Superchip; 2 relay, Positive heat only 14 = Superchip; 3 relay, Positive heat only ET = Extended Temperature; -4°F to 131°F (-20°C to 55°C) IM = Internal Modem M = Modem Power Option TB = RS485 Terminal Block for Panel Mount Enclosure TU = Translation Utility Disk					

### Accessories:

KEPS-KEP1-32 = KEP RS232 DDE server for SUPERtrol.  
 KEPS-MBS32 = Modbus RTU OPC/DDE server  
 SUPERtrol 2 and LEVELtrol 2 • 32 Bit DDE Server  
 Modem Available, see MPP-2400 and MPP-2400N (requires M option)  
 Two Way Pager Available, see MPP-TWP (requires M option)  
 Serial printer available, see P1000, P295  
 Ethernet Port Server available, see IEPS  
 RS-422/485 to RS-232 Communication Adaptor available, see CA285  
 Remote metering and data collection software available, see TROLlink

# ES-747

## Flow Computer for Liquid and Gas Applications

### Features

- Supports Pulse Producing Flowmeters
- Rate/Total and Batching Functions
- Universal Viscosity Curve (UVC) and Strouhal/Roshko Advanced Linearization Methods
- Gas & Liquid Flow Equations (Volume, Mass, Corrected Volume)
- API 2540, AGA-7 Equations
- 10 Selectable Fluid Tables
- Advanced Batching Features: Overrun Compensation, Print End of Batch
- Menu Selectable Hardware & Software Features
- Data Logging
- Two Line LCD or VFD Display

### Description:

The ES-747 Flow Computer satisfies the instrument requirements for pulse producing flowmeters in liquid and gas applications. Multiple flow equations and instrument functions are available in a single unit with many advanced features.

The alphanumeric display shows measured and calculated parameters in easy to understand format. Single key direct access to measurements and display scrolling is supported

The versatility of the ES-747 permits a wide measure of versatility within the instrument package. The various hardware inputs and outputs can be "soft" assigned to meet a variety of common application needs. The user "soft selects" the usage of each input/output while configuring the instrument.

The isolated analog output can be chosen to follow volume flow, corrected volume flow, mass flow, temperature, pressure or density by means of a menu selection. Most hardware features are assignable by this method.

The user can assign the standard RS-232 Serial Port for data recording, transaction printing, or for connection to a computer.

Front panel selection of fluid type is supported.

Linearization options include UVC, Strouhal/Roshko and 40 point linearization tables.

A Service or Test mode is provided to assist the user during start-up system check out by monitoring inputs and exercising outputs and printing system setup.



- Isolated Pulse and Analog Outputs Standard
- RS-232 Port Standard, RS-485 Optional
- Windows™ Setup Software
- DDE Server & HMI Software Available

### Specifications:

#### Flow Meters and Computations

Meter Types: Supports pulse producing meters including: vortex, single rotor turbine, magnetic, PD flowmeter  
Linearization: 40 point table, UVC table or Strouhal/Roshko  
Computations: Volume, Corrected Volume & Mass  
Fluid Computations: Density, Viscosity

#### Environmental

Operating Temperature: 0°C to +50°C  
Storage Temperature: -40°C to +85°C  
Humidity : 0-95% Non-condensing  
Materials: U.L. approved

**Approvals:** CE Compliant, UL/CUL Listed

#### Display

Type: 2 lines of 20 characters, Blue VFD or Backlit LCD  
Character Size: 0.3" nominal  
User programmable label descriptors and units of measure

#### Keypad

Keypad Type: Membrane Keypad with 16 keys  
Keypad Rating: Sealed to Nema 4

#### Enclosure

Size: See Dimensions  
Depth behind panel: 6.5" including mating connector  
Type: DIN  
Materials: Plastic, UL94V-0, Flame retardant  
Bezel: Textured per matt finish

#### Fluid Types

General Purpose, Water, Skydraul 500B, 50/50 Ethylene, Air, Propane, MIL-C-7024D, MIL-O-5606, MIL-23699, JETA-1, Diesel, Methanol

### Real Time Clock

The ES-747 is equipped with a battery backed real time clock with display of time and date.

Format:

12 or 24 hour time display  
Day, Month, Year date display

### Excitation Voltage

Menu Selectable: 5, 12 or 24 VDC @ 100 mA (fault protected with self resetting fuse)

### Relay Outputs

The relay outputs are menu assignable to (Individually for each relay) Low Rate Alarm, Hi Rate Alarm, Prewarn Alarm, Preset Alarm, Temperature, Pressure, Density or General purpose warning (security).

Number of relays: 2 (4 optional)

Contact Style: Form C contacts

Contact Ratings: 5 amp, 240 VAC or 30 VDC

Capabilities: Alarm Delay, Setpoint, Hysteresis, Duration

### Power Input

The factory equipped power option is internally fused. An internal line to line filter capacitor and MOV are provided for added transient suppression.

110 VAC Power: 85 to 127 Vrms, 50/60 Hz

220 VAC Power: 170 to 276 Vrms, 50/60 Hz

DC Power:

12 VDC (10 to 14 VDC)

24 VDC (14 to 28 VDC)

Power Consumption:

AC: 11.0 VA (11W)

DC: 300 mA max.

### Flow Inputs:

#### Pulse Inputs:

Number of Flow Inputs: one input available for single pickup or with dual pickups or quadrature

Input Impedance: 10 K $\Omega$  nominal

Pullup Resistance: 10 K $\Omega$  to 5 VDC (menu selectable)

Pull Down Resistance: 10 K $\Omega$  to common

Trigger Level: (menu selectable)

High Level Input

Logic On: 3 to 30 VDC

Logic Off: 0 to 1 VDC

Low Level Input (mag pickup)

Sensitivity:

10 mV or 100 mV

Minimum Count Speed:

Menu selectable: 1-99 seconds

Maximum Count Speed:

Menu Selectable: 40Hz, 3000Hz or 20 kHz

Overvoltage Protection: 50 VDC

### Control Inputs

Switch Inputs are menu selectable for Start, Stop, Reset, Lock, Inhibit, Alarm Acknowledge, Print or Not Used.

Control Input Specifications

Number of Control Inputs: 3

Input Scan Rate: 10 scans per second

Logic 1: 4 - 30 VDC

Logic 0: 0 - 0.8 VDC

Input Impedance: 100 K $\Omega$

Control Activation:

Positive Edge or Pos. Level based on product definition for switch usage.

### Auxiliary / Compensation Inputs

The auxiliary/compensation inputs are menu selectable for temperature, pressure, density or not used. These inputs are used for the compensated inputs when performing compensated flow calculations. They can also be used as a general purpose input for display and alarming.

Number of inputs: 2

Operation: Ratiometric

Accuracy: 0.02% FS at 20° C

Basic Measurement Resolution:

16 bit

Update Rate: 1 update/sec minimum

Automatic Fault detection:

Signal Over-range/under-range

Current Loop Broken

RTD short

RTD open

Fault mode to user defined default settings

Fault Protection:

Reverse Polarity: No ill effects

Over-Voltage Limit (Voltage Input): 50 VDC

Available Input Ranges

Voltage: 0-10 VDC, 0-5 VDC, 1-5 VDC

Current: 4-20 mA, 0-20 mA

Resistance: 100 Ohms DIN RTD

Proprietary Thermistor

100 Ohm DIN RTD (liquid equations only)  
(DIN 43-760, BS 1904):

Three Wire Lead Compensation

Internal RTD linearization learns ice point resistance  
1 mA Excitation current with reverse polarity protection

Temperature Resolution: 0.1°C

### Isolated Analog Output

The analog output is menu assignable to correspond to the Uncompensated Volume Rate, Corrected Volume Rate, Mass Rate, Temperature, Pressure, Density, Volume Total, Corrected Volume Total or Mass Total.

Type: Isolated Current Sourcing

Available Ranges: 4-20 mA, 0-20 mA

Resolution: 12 bit

Accuracy: 0.05% FS at 20° C

Update Rate: 1 update/sec minimum

Temperature Drift: Less than 200 ppm/C

Maximum Load: 1000 ohms (at nominal line voltage)

Compliance Effect: Less than .05% Span

60 Hz rejection: 40 dB minimum

Calibration: Operator assisted Learn Mode

Averaging: User entry of damping constant to cause a smooth control action

### Isolated Pulse output

The isolated pulse output is menu assignable to Uncompensated Volume Total, Compensated Volume Total or Mass Total

Pulse Output Form: Photo MOS Relay

Maximum On Current: 100 mA

Maximum Off Voltage: 30 VDC

Saturation Voltage: 1.0 VDC

Maximum Off Current: 0.1 mA

Pulse Duration: 10 mSec or 100 mSec (user selectable)

Pulse output buffer: 256

Fault Protection

Reverse polarity: Shunt Diode

### Serial Communication

The serial port can be used for printing, data recording, and/or communication with a computer.

RS-232:

Device ID: 01-99

Baud Rates: 300, 600, 1200, 2400, 4800, 9600, 19200

Parity: None, Odd, Even

Handshaking: None, Software, Hardware

Print Setup: Configurable print list and formatting

RS-485: (optional 2nd COM port)

Device ID: 01-247

Baud Rates: 2400, 4800, 9600, 19200

Parity: None, Odd, Even

Protocol: Modbus RTU (Half Duplex)

### Setup Diskette Capabilities

Capabilities include: View Live Results Configure unit, Upload and Download to unit, Load and Save to file, Print Setup,

### Data Logging Capabilities

Capabilities:

Permits unit to automatically gather data during use.

Data Log List:

User selectable: includes process variables, totalizers, set points, time and date

Data Log Event Trigger:

selectable: includes interval, time of day, front key, external contact, end of batch

Data Log Format:

selectable: Printer format, Database CSV format

Data Transmission:

Selectable: Output may be transmitted immediately or held in data log for later polling

Remote Request Capabilities include:

Send data log, clear data log

### External Modem Support Capabilities:

Compatibility: Hayes Compatible

Polling Capabilities:

Answers incoming calls, responds to requests for information of action

Call Out Capabilities:

Can initiate call on user selectable event condition, or upon error

Error Handling:

Supports multiple retry, automatic disconnect upon loss of line or remote inactivity

**Fig. 1: Standard Dimensions**

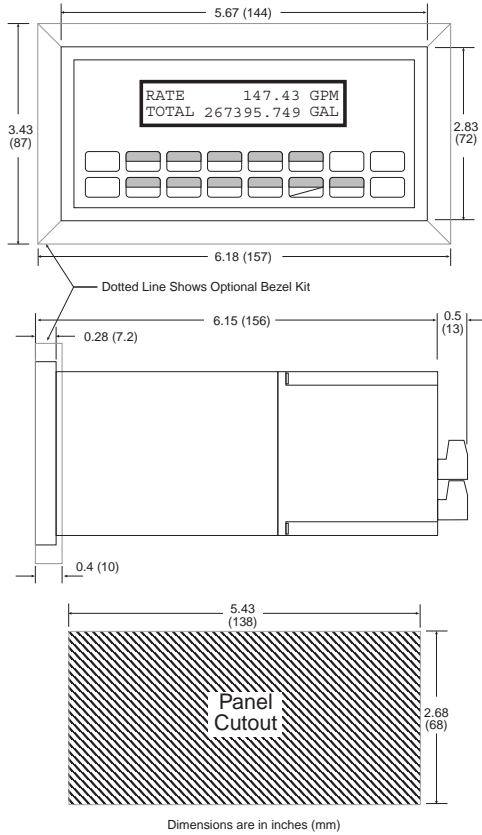

**Fig. 2: Wall Mount ("W" mounting option) Dimensions**

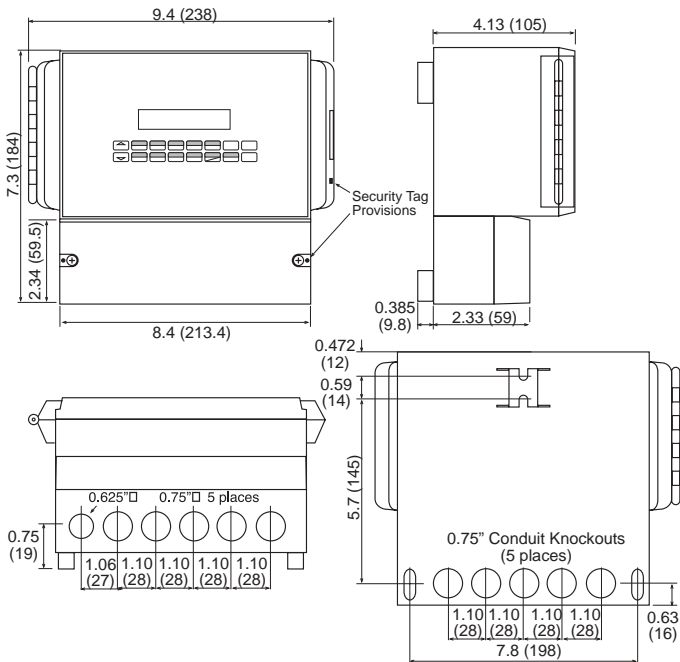

**Terminal Designations**

1	DC OUTPUT	1	Flow IN
2	PULSE IN 1	2	Pressure
3	PULSE IN 2	3	Thermistor
4	COMMON	4	RTD EXCIT +
5	RTD SENS +	5	RTD SENS +
6	RTD SENS -	6	RTD SENS -
7	CNTR IN 1	7	CNTR IN 1
8	CNTR IN 2	8	CNTR IN 2
9	CNTR IN 3	9	CNTR IN 3
10	COMMON	10	PULSE OUTPUT +
11	PULSE OUTPUT -	11	PULSE OUTPUT -
12	ANALOG OUTPUT +	12	ANALOG OUTPUT +
13	ANALOG OUTPUT -	13	ANALOG OUTPUT -
14	4-20 mA	14	4-20 mA
15	NC	15	NC
16	COM RLY1	16	COM RLY1
17	NO	17	NO
18	COM RLY2	18	COM RLY2
19	NO	19	NO
20	COM RLY3	20	COM RLY3
21	NO	21	NO
22	COM RLY4	22	COM RLY4
23	NO	23	NO
24	POWER IN	24	POWER IN

**Terminal Layout**

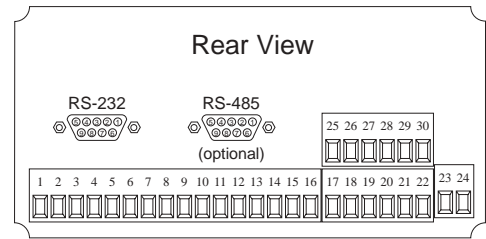

**Ordering Information**

**Example** ES747 L 1 A 0 P

**Series:** ES747= ES-747

**Display Type:** L= LCD, V= VFD

**Input Type:** 1= 110 VAC, 2= 220 VAC, 3= 12 VDC (10 to 14 VDC), 4= 24 VDC (14 to 28 VDC)

**Relays:** A= 2 SPDT Relays, B= 4 SPDT Relays

**Network Card:** 0= None (STD), 2= RS485/Modbus (optional 2nd COM port)

**Mounting:** P= Panel Mount (see Fig. 1), N= NEMA 4 Wall Mount (see NEMAtrolST4X), W= NEMA 12/13 Wall Mount w/ Clear Cover (see Fig.2), E= Explosion Proof (No Button Access) (see XHVD 7/4), X= Explosion Proof (with Button Access) (see XTROL 7/4)

**Options:** TB= RS485 Terminal Block for Panel Mount Enclosure, ET= Extended Temperature (-4°F to 131°F (-20°C to 55°C)), IM = Internal Modem, M = Modem Power Option

**Accessories:** KEPS-KEP1-32 (KEP RS232 for SUPERtrol 1, SUPERtrol 1LE, SUPERtrol 2 and LEVELtrol 2 • 32 Bit OPC/DDE Server), KEPS-MBS32 (Supports RS485 for ST1, ST1LE, ST2, LT2, MRT, DRT & MB2 (Modbus RTU)), Modem Available, see MPP-2400 and MPP-2400N (requires M option), Serial printer available, see P1000, P295, Ethernet Port Server available, see IEPS, RS-422/485 to RS-232 Communication Adaptor available, see CA285, Remote metering and data collection software available, see TROLlink

Flow Instruments  
FLOW COMPUTERS

# MASStrol

## Mass Flow Computer

### Features

- Compensates Steam, Gases and Liquids for Temperature and Pressure to Yield Corrected Volume, Mass and Heat Flow.
- Two Line by 20 Character Super Twist Back-Lit LCD Display
- Square Root Extraction of DP Inputs
- 16 Point Linearization
- Displays Compensated Rate and Total Flow
- Takes a Direct 100  $\Omega$  Platinum RTD (4 wire)
- Flow Rate, Temperature and Pressure Alarms
- 4-20 mA and Pulse Outputs Based on Compensated Flow
- Non-volatile Memory
- 24 Volt Excitation Provided
- Front Panel NEMA 4X/IP 65 Rated



### Description:

The KEP MASStrol is a microprocessor based instrument designed to measure compensated flow in an industrial environment. Three analog inputs for temperature, pressure and flow are provided to measure the parameters needed to calculate the actual compensated mass, volume or heat flow.

Special signal conditioning circuitry is included to allow direct connection of platinum resistance temperature detectors (RTD'S). A high speed digital input is provided to interface with pulse output type flowmeters. As an alternative, voltage inputs or current loops can be used for the above.

All instrument interface is with a 32 point screw terminal strip on the rear of the instrument.

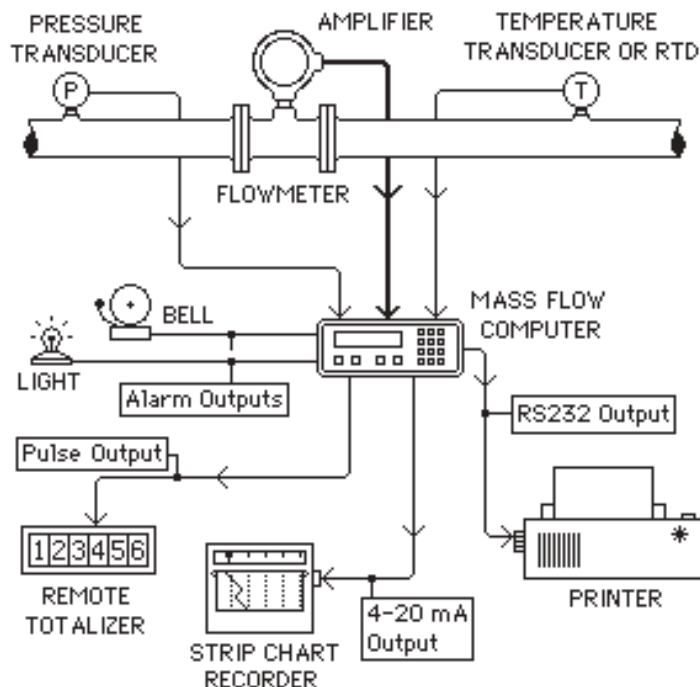

### Flow Computer Application

- § Pressure transducer sends 0-5V or 4-20mA signal to Flow Computer.
- § 100 $\Omega$ , 4 wire, RTD direct hookup to Flow Computer.
- § Turbine flowmeter sends digital signal to Flow Computer.
- § Flow Computer calculates flow and generates output signals.
- § 5 V pulse out to remote totalizer in supervisory area.
- § 4-20 mA out to strip chart recorder tracks trends.
- § RS232 out to printer for data logging.
- § Alarm relays activate bell and/or light as needed.

**General Specifications:****OVERALL ACCURACY:** .25%**ENVIRONMENTAL:**

Operating Temperature:

32° to 122° F (0° to 50° C)

Storage Temperature:

-10 to 160 F (-23 to 71 C)

Humidity: 0 to 90% Noncondensing

Front Bezel: NEMA 4X/IP 65

Case: ABS Plastic

**Listing:** CE Compliant**POWER:** (Internally Fused)

Nominal Line Voltage: 100, 110, 220 or 240 VAC (50/60 Hz)

24VDC  $\pm 20\%$  or 12VDC  $+20\%/-10\%$ 

Power Consumption: 10 Watts max

**Input Specifications:**

The following applies to all inputs. Inputs are referenced to signal ground. All ground terminals are connected internally.

NOTE: All inputs are single-ended with one leg grounded. The exception is the RTD input which is differential but is referenced to ground.

**CURRENT INPUTS:**Input Impedance: 100 $\Omega$ 

Range: 0-20mA, 4-20mA

Maximum sustained input voltage:

5 VDC (Fault Condition)

Resolution:  $\pm 0.024\%$  FS**VOLTAGE INPUTS:**Input Impedance: 115 k $\Omega$ 

Range: 0-5V, 0-10V

Resolution:  $\pm 0.024\%$  FS**TEMPERATURE INPUTS:**Compatible RTD type: 100 $\Omega$  Platinum( $\alpha = .00385$ ; DIN 43-760 Calibration)

Lead Wire Compensation: 4 Wire

Configuration: 2, 3 or 4 wire (4 wire cable required)

Excitation Current: 2mA typical

Max Fault Current: 15mA

Max Volt on sense inputs: 50 VDC

Rejection of 50 or 60Hz signal: 40dB minimum (Automatically based on line frequency)

Raw Accuracy:  $\pm .5^\circ\text{C}$ **DIGITAL FLOW INPUT:**

Range: 3-30 VDC Pulse

Max Input Frequency: 40kHz max

Min pulse width: 10 $\mu\text{sec}$  (with 40kHz filter)

Thresholds: OFF is less than 2.0V; ON is greater than 2.5V

Input Impedance: 40k $\Omega$  to ground.

Minimum Frequency to Maintain Rate Display: 5 Hz

**Output Specifications:****ANALOG OUTPUT:**

Range: 4-20mA DC, sink only.

Compliance Voltage Range: 3.0 - 24 VDC

Load Type: Non Inductive

Accuracy:  $\pm .5\%$  FS

Update Rate: 1Hz

**RELAY OUTPUTS:**

One relay is a flow alarm output and a second is for other alarm conditions. Each has the following electrical specifications:

Type: Dry Contact, Form C

Contact Rating: 10A @ 115/230VAC/28VDC

**AUXILIARY POWER OUTPUT:** (AC powered units only)

Voltage: 24VDC regulated and filtered

Isolation: 230VAC max

Current: 0 to 100mA

Protection: Short Circuit Proof

The 24VDC Output is supplied with a self resetting fuse.

**DIGITAL FLOW PULSE OUTPUT:**This output is intended to drive a counter with a minimum input impedance of 1000 $\Omega$ . It is compatible with TTL and 5V CMOS logic inputs.

Output High Voltage:

No load: 4.5 Volts min

4.0 mA source: 4.0 Volts min

Output Low Voltage:

No Load: 0.2 Volts max

4.0 mA sink: 1.0 Volts max

Output waveform: Symmetric square wave above 1Hz

100msec pulse below 1Hz

Frequency Range: 0 to 50kHz

Max Slew Rate: 27 Volts/ $\mu\text{sec}$ 

Sustained Fault Voltage for no permanent damage: 7 Volts

**RS232 COMMUNICATIONS:**

Connector: 25 Pin Sub-D

Input Impedance: 3000 $\Omega$  to 7000 $\Omega$ 

Compliance Voltage:

Output: -25 to -5 (Mark);

5 to 25 (Space); Volts

Input: -25 to -3 (Mark);

3 to 25 (Space); Volts

Protection: Short circuit proof.

Protocol: 8 bits, 1 Stop bit

Parity: None (Not monitored)

Available Baud Rates: 300, 1200, or 9600

**DATA DISPLAY AND KEYPAD:**

Internal 2 line by 20 character dot matrix, Backlit LCD display.

Sealed, 16 key panel featuring numeric keys

0- 9, plus the following keys:

A Advance through menus

B Back up through menus

C Cancel current menu selection

D Decimal point key

ENT ..... General purpose enter or recall data key

CLR ..... Data clear key

**OPERATION:**

Through the 16 button, NEMA 4X/IP 65, front keypad, the operator enters all parameters necessary to configure the mass flow computer. One MASStrol will handle all of your mass flow requirements.

The type of flow equations desired (steam tables, ideal gas law or liquids) must be selected first. For steam flow and heat measurement, the 1967 ASME steam tables for both saturated and superheated steam are stored in memory. For gases, the ideal gas law is used. For liquids and heat calculations, factors are entered through the front keypad.

Additionally, the following hardware parameters must be entered to configure the MASStrol input signal types (from the flow, temperature and pressure transmitters) along with their corresponding ranges or K factors; alarm set points may be entered; the output range for the 4-20 mA signal and the pulse output scaling factor. The operator can select, in any order, up to 16 parameters to display on the read out.

If it is so desired, the operator then can lockout the unit from changes by entering a five digit lockout code.

Optional RS232 serial communications for ease of programming and timely printouts of flow results and/or parameters is available. If RS232 two way communications and the keypad are being used simultaneously, the serial port takes precedence.

**SOFTWARE ACCESSORIES:**K1 Diskette:

A diskette program is available to assist in the computation of the K1 term. The K1 factor is used in Orifice/Pitot/Annubar calculations. The K1 factor is the calibration factor for the meter run. It is part of the Variables menu for flow input values (analog).

MASSCON Diskette:

The MASSCON diskette program facilitates the configuration and calibration of the flow computer. The program runs on PC compatibles and communicates through the RS232 port.

**TERMINAL BLOCK DESIGNATIONS:**

PIN	RTD	VOLTAGE IN	CURRENT IN	FUNCTION
1	RTD EXCITATION +	-----	-----	CHANNEL 1  TEMPERATURE
2	RTD SENSE +	-----	-----	
3	RTD SENSE -	-----	-----	
4	RTD EXCITATION -	-----	I IN +	
5	COMMON (SHIELD)	V IN - (COM)	I IN - (COM)	
6	-----	V IN +	-----	
7	RTD EXCITATION +	-----	-----	CHANNEL 2 PRESSURE or AUX. TEMP.
8	RTD SENSE +	-----	-----	
9	RTD SENSE -	-----	-----	
10	RTD EXCITATION -	-----	I IN +	
11	COMMON (SHIELD)	V IN - (COM)	I IN - (COM)	
12	-----	V IN +	-----	
13	-----	-----	I IN +	CHANNEL 3 FLOW ANALOG INPUT
14	COMMON (SHIELD)	V IN - (COM)	I IN - (COM)	
15	-----	V IN +	-----	
16	EXCITATION VOLTAGE (5.6K PULL-UP TO 5VDC)			CHANNEL 3 FLOW PULSE INPUT
17	PULSE INPUT (3-30VDC)			
18	COMMON (SHIELD)			
19	ANALOG OUTPUT (SINK)			ANALOG OUT
20	PULSE OUTPUT			5V SCALED PULSE OUT
21	COMMON (SHIELD)			
22	N.O.			ALARM RELAY
23	N.C.			
24	COMMON			
25	N.O.			FLOW ALARM RELAY
26	N.C.			
27	COMMON			
28	115/230 VAC 50/60Hz			POWER (AC)
29	115/230 VAC 50/60Hz			
30	+24 VOLTS	24VDC OUT	+ VDC IN	POWER (DC)
31	24 VOLTS RETURN	(AC POWERED UNITS ONLY)	-DC (COM) (DC POWERED UNITS ONLY)	
32	CHASSIS COMMON			

**TYPICAL HOOKUP:**

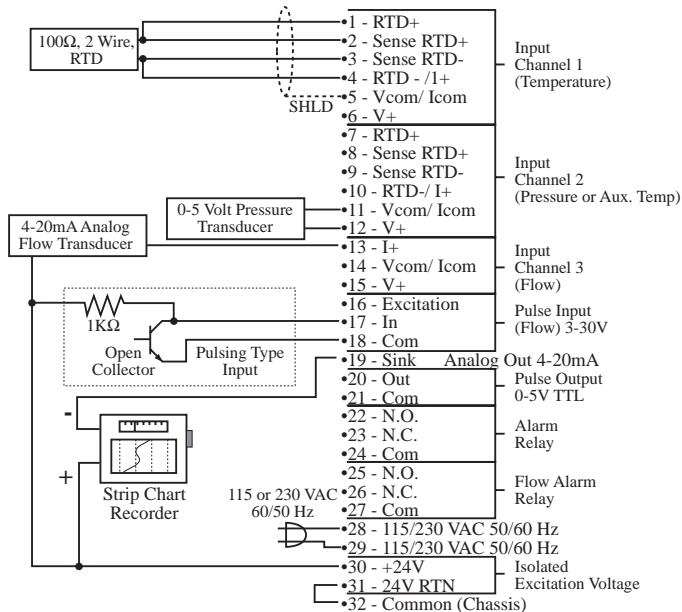

**Ordering Information**

**Example:** MFC A 1 BL

**Series:** MFC

**Operating Voltage:** A: 115 VAC ± 15% at 50/60Hz  
B: 230 VAC ± 15% at 50/60Hz  
C: 24 VDC ± 20%  
D: 12 VDC -10, +20%

**Options:** 1: RS-232 Serial Interface

**Display:** BL: Backlit Display (standard)

**Accessories:**

FLEXCOVER #36120  
NEMA 4X wall mount enclosure available, see NEMATROL  
Explosion Proof housing available, see XTROL7/4  
Serial printer available, see P1000, P295  
Ethernet Port Server available, see IEPS  
Remote metering and data collection software available, see TROLLink

**Dimensions:**

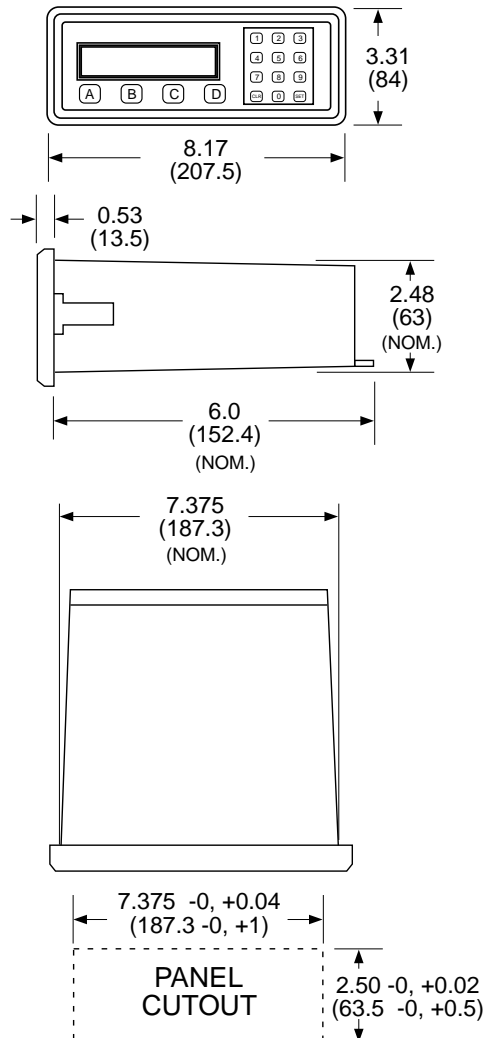



# DPFC

## DIFFERENTIAL PRESSURE FLOW COMPUTER

### Features

- Compensates Steam, Gases and Liquids for Temperature and Pressure to Yield Corrected Volume, Mass and Heat Flow.
- Two Line by 20 Character Super Twist Back-Lit LCD Display
- Accepts Single or Dual Differential Pressure (DP) Inputs
- Square Root Extraction of DP Inputs
- 16 Point Linearization
- Displays Compensated Rate and Total Flow
- Takes a Direct 100  $\Omega$  Platinum RTD (4 wire)
- Flow Rate, Temperature and Pressure Alarm
- 4-20 mA and Pulse Outputs Based on Compensated Flow
- 24 Volt Excitation Provided
- Front Panel NEMA 4X/IP 65 Rated



### Description

The KEP DPFC is a microprocessor based instrument designed to measure compensated flow in an industrial environment. Four analog inputs for temperature, pressure and dual differential pressure are provided to measure the parameters needed to calculate the actual compensated volume, mass or heat flow.

Special signal conditioning circuitry is included to allow direct connection of platinum resistance temperature detectors (RTD'S). Voltage inputs or current loops can be used for the above.

All instrument interface is with a 32 point screw terminal strip on the rear of the instrument.

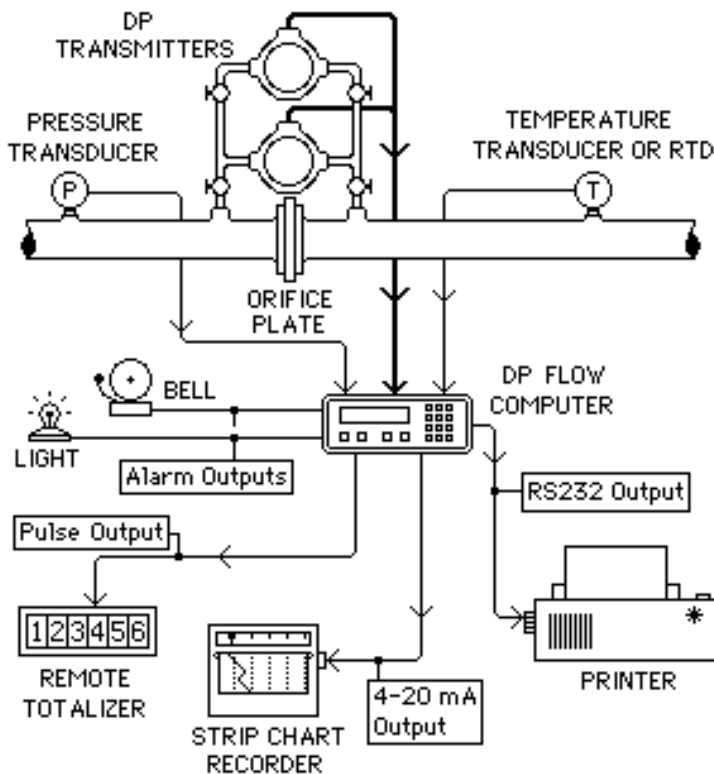

### DP Flow Computer Application

- § Pressure transducer sends 0-5V or 4-20 mA signal to Flow Computer.
- § 100 $\Omega$ , 4 wire, RTD direct hookup to Flow Computer.
- § DP transmitters send signals to Flow Computer.
- § Flow Computer calculates flow and generates output signals.
- § 5 V pulse out to remote totalizer in supervisory area.
- § 4-20 mA out to strip chart recorder tracks trends.
- § RS232 out to printer for data logging.
- § Alarm relays activate bell and/or light as needed.

**General Specifications**

**OVERALL ACCURACY:** .25%

**ENVIRONMENTAL:**

Operating Temperature: 32 to 122 F (0 to 50 C)

Storage Temperature: -10 to 160 F (-23 to 71 C)

Humidity: 0 to 90% Noncondensing

Front Bezel: NEMA 4X/IP 65

Case: ABS Plastic

**Listing:** CE Compliant

**POWER:** (Internally Fused)

115 / 230 VAC ±15% (Switch Selectable)

or 24VDC ±20% or 12 VDC +20%/-10%

Frequency: 50/60Hz.

Power Consumption: 10 Watts max

**Input Specifications:**

The following applies to all inputs. Inputs are referenced to signal ground. All ground terminals are connected internally.

NOTE: All inputs are single-ended with one leg grounded. The exception is the RTD input which is differential but is referenced to ground.

**CURRENT INPUTS:**

Input Impedance: 100Ω

Range: 0-20mA, 4-20mA

Maximum sustained input voltage:

5 VDC (Fault Condition)

Resolution: .0244% FS

**VOLTAGE INPUTS:**

Input Impedance: 115 kΩ

Range: 0-5V, 0-10V

Resolution: .0244% FS

**TEMPERATURE INPUTS:**

Compatible RTD type: 100Ω Platinum

( $\alpha = .00385$ ; DIN 43-760 Calibration)

Lead Wire Compensation: 4 Wire

Configuration: 2, 3 or 4 wire (4 wire cable required)

Excitation Current: 2mA typical

Max Fault Current: 15mA

Max Volt on sense inputs: 50 VDC

Rejection of 50 or 60Hz signal: 40dB minimum (Automatically based on line frequency)

Raw Accuracy: ± .5°C

**Output Specifications:**

**ANALOG OUTPUTS:**

Range: 4-20mA DC, sink only.

Compliance Voltage Range: 3 - 24 VDC

Load Type: Non Inductive

Accuracy: ± .5% FS

Update Rate: 1Hz

**PULSE OUTPUT:**

This output is intended to drive a counter with a minimum input impedance of 1000Ω. It is compatible with TTL and 5V CMOS logic inputs.

Output High Voltage

No load: 4.5 Volts min

4.0 mA source: 4.0 Volts min

Output Low Voltage

No Load: 0.2 Volts max

4.0 mA sink: 1.0 Volts max

Output waveform: Symmetric square wave above 1Hz 100msec pulse below 1Hz

Frequency Range: 0 to 50kHz

Max Slew Rate: 27 Volts/μsec

Sustained Fault Voltage for no permanent damage: 7 Volts

**RELAY OUTPUTS:**

One relay is a flow alarm output and a second is for other alarm conditions. Each has the following electrical specifications:

Type: Dry Contact, Form C

Contact Rating: 10A @ 115/230VAC/28VDC

**AUXILIARY POWER OUTPUT:** (AC Powered units only)

Voltage: 24VDC regulated and filtered

Isolation: 230VAC max

The 24VDC Output is supplied with a self resetting fuse.

Current: 0 to 100mA

Protection: Short Circuit Proof

**RS232 COMMUNICATIONS:**

Connector: 25 Pin Sub-D

Input Impedance: 3000Ω to 7000Ω

Compliance Voltage:

Output: -25 to -5 (Mark);

5 to 25 (Space); Volts

Input: -25 to -3 (Mark);

3 to 25 (Space); Volts

Protection: Short circuit proof.

Protocol: 8 bits, 1 Stop bit

Parity: None (Not monitored)

Available Baud Rates: 300, 1200, or 9600

**DATA DISPLAY AND KEYPAD:**

Internal 2 line by 20 character dot matrix LCD display. Sealed, 16 key panel featuring numeric keys

0- 9, plus the following keys:

A Advance through menus

B Back up through menus

C Cancel current menu selection

D Decimal point key

ENT ..... General purpose enter or recall data key

CLR ..... Data clear key

**OPERATION:**

Through the 16 button, NEMA 4X/IP 65, front keypad, the operator enters all parameters necessary to configure the DPFC. No additional input cards or dip switch settings are needed.

The operator selects the type of compensation desired for the medium (steam, ideal gas or liquid). For steam flow and heat measurement the 1967 ASME steam tables for saturated and superheated steam are stored in memory. For gases and liquids, the necessary factors are entered in by the operator.

Additionally, the following hardware parameters must be entered to configure the DPFC input signal types (from the temperature, pressure and differential pressure transmitters) along with their corresponding ranges or factors and alarm set points. Also the 4-20mA output, pulse output and optional serial port can be set up. If desired, the operator can lockout the unit from changes by entering a five digit lockout code.

The optional RS232 serial communications allows for timely printouts of flow results and/or parameters as well as parameter down load and up load for easy computer programming.

**SOFTWARE ACCESSORIES:**

K1 Diskette:

A diskette program is available to assist in the computation of the K1 term. The K1 factor is used in Orifice/Pitot/Annubar calculations. The K1 factor is the calibration factor for the meter run. It is part of the Variables menu for flow input values (analog).

MASSCON Diskette:

The MASSCON diskette program facilitates the configuration and calibration of the flow computer. The program runs on PC compatibles and communicates through the RS232 port.

**TERMINAL BLOCK DESIGNATIONS:**

PIN	RTD	VOLTAGE IN	CURRENT IN	FUNCTION
1	RTD EXCITATION +	-----	-----	CHANNEL 1 TEMPERATURE
2	RTD SENSE +	-----	-----	
3	RTD SENSE -	-----	-----	
4	RTD EXCITATION -	-----	I IN +	
5	COMMON (SHIELD)	V IN - (COM)	I IN - (COM)	
6	-----	V IN +	-----	
7	RTD EXCITATION +	-----	-----	CHANNEL 2 PRESSURE or AUX. TEMP.
8	RTD SENSE +	-----	-----	
9	RTD SENSE -	-----	-----	
10	RTD EXCITATION -	-----	I IN +	
11	COMMON (SHIELD)	V IN - (COM)	I IN - (COM)	
12	-----	V IN +	-----	
13	-----	-----	I IN +	CHANNEL 3 FLOW (LOW) DP
14	COMMON (SHIELD)	V IN - (GND)	I IN - (GND)	
15	-----	V IN +	-----	
16	-----	-----	I IN +	CHANNEL 4 FLOW (HIGH) DP2
17	-----	V IN +	-----	
18	COMMON (SHIELD)	V IN - (COM)	I IN - (COM)	
19	ANALOG OUTPUT (SINK)			ANALOG OUT
20	PULSE OUTPUT			5V SCALED PULSE OUT
21	COMMON (SHIELD)			
22	N.O.			ALARM RELAY
23	N.C.			
24	COMMON			
25	N.O.			FLOW ALARM RELAY
26	N.C.			
27	COMMON			
28	115/230 VAC 50/60Hz			POWER (AC)
29	115/230 VAC 50/60Hz			
30	+24 VOLTS	24VDC OUT	+ VDC IN	POWER (DC)
31	24 VOLTS RETURN	(AC POWERED UNITS ONLY)	-DC (GND)	
32	CHASSIS COMMON			

**TYPICAL HOOKUP:**

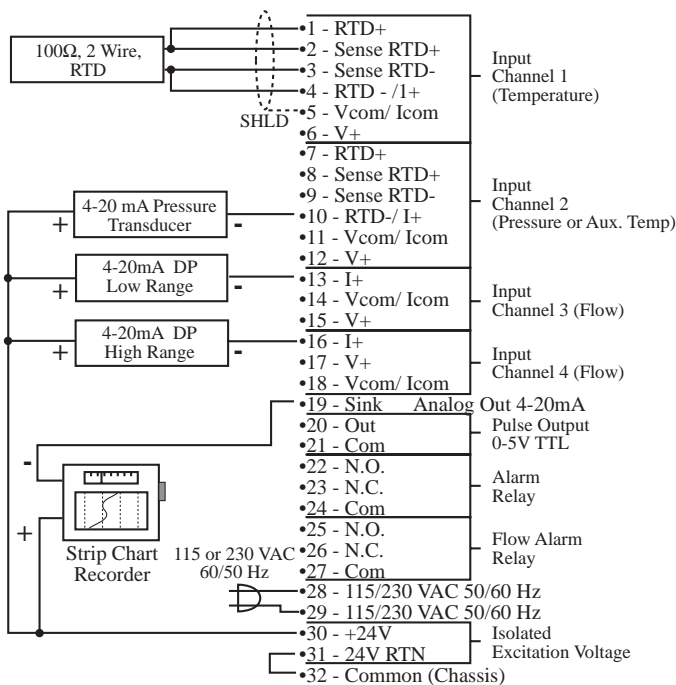

**Ordering Information**

**Example:** DPFC A 1  
**Series:** DPFC  
**Operating Voltage:**  
 A: 115 VAC ± 15% at 50/60Hz  
 B: 230 VAC ± 15% at 50/60Hz  
 C: 24 VDC ± 20%  
 D: 12 VDC -10, +20%  
**Options:**  
 1: RS-232 Serial Interface

**Accessories:**  
 FLEXCOVER #36120  
 NEMA 4X wall mount enclosure available, see NEMATROL  
 Explosion Proof housing available, see XTROL7/4  
 Serial printer available, see P1000, P295  
 Ethernet Port Server available, see IEPS  
 Remote metering and data collection software available, see TROLLink

**Dimensions:**

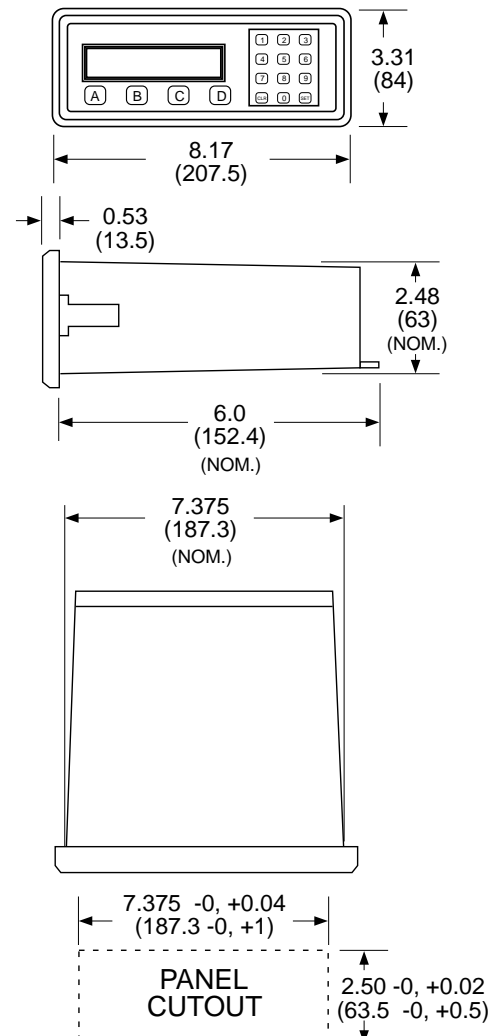

Flow Instruments  
FLOW COMPUTERS

# Communications Solutions Tutorial

In recent years there has been a virtual explosion of new technologies and methods which greatly simplify the exchange of information between systems. This virtual explosion in new technologies complement many of the traditional direct wiring approaches of interconnecting instruments around a plant, complex, city, or region.

KEP seeks to assist our customers in "getting connected" by using the serial communication ports provided on many of our models such that they may be used for communications with computers, for modems, for printing, for datalogging, and in wire-line and wireless communications.

KEP offers a variety of compatible hardware and software system building blocks which many users find helpful in interconnecting their instruments to their computer over their preferred communication channel.

**How can I get a printed report?** Many instruments may be supplied with a standard or optional RS-232 serial port which may be connected to a printer with a RS-232 serial interface. Printers are purchased separately as an accessory.

**What information can I get on my printed report?** The printing capabilities of instruments vary widely. Instruments with more advanced printing capabilities permit the user to decide on the form length, include a custom print header, time and date, sequential print number, and all the desired information. Some models include a more limited print list. Basic models support only the printing of a single number.

**How can I initiate the report to print?** Depending on the model being used there may be one or more ways to initiate a print. These include: Remote Print Switch, Local Print Key, End of Batch, Interval, and Time of Day.

**How can I get information into my PC?** There are several issues involved with getting information into a PC from an instrument. The first is the decision for the communication channel to be used. The second is the data gathering software (server). The final is the selection of the software that will display or store the information for the operator (client software).

**What is a Server or DDE Server?** A server is a communication utility program that you purchase which enables you to easily communicate with an instrument or PLC. Most programs offer a wizard which guides you through naming and selecting the communication channel with its com port and setting, the instruments which will be on that cable and the various measurements (or tags) being made by each instrument. Other programs will latter reference instrument name and tag.

**How can I get information into my spread sheet?** One of the simplest ways involves using a "DDE or OPC Server" which has been configured to constantly gather information from your instrument to make it available for other programs to access. (See using a dde server.) The information is accessed in the desired cell of your spread sheet by entering the following: "=KEPDDE|UNIT\_NAME!DATA\_ITEM\_NAME". One of the nice aspects of this approach is there is no need to write a program in many applications. A DDE server and the above command is all you need.

**I want to write my own program. How do I go about it?** You will need to consider using an off the shelf server or writing your own custom program in the language of your choice. Each instrument with serial communications has a special user manual which describes the format of a request for information and a list of the information. These will act as an aid while you are writing and debugging your program.

**What is an HMI Software?** HMI software is a software toolbox that enables a user to create custom screens for displaying information and controlling his plant. Capabilities include: controls and displays on touch screen, graphics symbols or object libraries, real time trending, data logging, and alarming. The software toolbox also includes a powerful programming or scripting language.

**What do I need to get information into my Human Machine Interface Software?** DDE and OPC Servers are routinely used. Alternately, custom scripting may be used in some cases.

**What are the some of the common communications possibilities on the market?** The choice of communications solutions available on the market is quite large. These include direct connect, wireless, fiber optic, LAN's and those which utilize the phone system. There are many others. Each technique offers advantages based on the needs of the system.

**What is a hardware interface?** The sender and receiver of information must match. This includes at the electrical signal level and at the low level communication settings. Industry standards exist for defining the hardware interface for signaling of information. These include RS-232, RS-422 and RS-485. There are a range of related communication settings which include baud rate, parity, start and stop bits which further clarify the interface.

**What is RS-232 and how far can I send it?** RS-232 is an industry standard for electrical signal levels. It is commonly used with many serial devices where the information will be send over distances not to exceed 50-200'. RS-232 ports are provided on all personal computers with a connector style known as mini-D or D-Sub.

**What is RS-485 and how far can I send these signals?** RS-485 is an industry standard for electrical signal levels. It is commonly used with many serial devices where the information will be send over distances not to exceed 4000'. Information is carried of 3 wires including a ground reference. RS-485 to RS-232 adapters are required to provide connections to the RS-232 ports on all personal computers.

**What is a protocol?** A protocol is an agreed upon method for exchanging information. It is used to decide on the method of formatting information that will be carried along a communication cable. An example would be the MODBUS-RTU protocol used on many instruments. However, there are a vast number on the market place.

**What is remote metering?** This may be described as any approach that is used to access information from a remote instrument to a centralized PC by connecting to and then polling an instrument for information. Telephone (modem) and wireless systems are commonly used.

**What is Wireless Communications?** Wireless if a term that includes a variety of technologies which do not require the sender and receiver of the system be directly connected by a wire cable. Instead a wireless transceiver is used. In common usage it may be divided into subclassifications. Common ones include wireless telephone, wireless one and two way personal messaging or paging, and radio telemetry.

**What is the cost of a wireless solution?** The costs of initial equipment, and installation cost vary. There is usually a monthly service charge associated with each transceiver that is based on the amount of air time, or amount of information to be transferred. There are often reduced charges for off peak hour usage.

# KEPServer

*SUPERtrol Series 32 Bit Device Driver for KEPware's KEPServer*

## Description

KEPware's 32 bit **KEP SUPERtrol** device driver works in conjunction with KEPware's **DDE Server** (KEPServer) to exchange data between DDE clients and Kessler-Ellis Products SUPERtrol devices. Block reads are optimized automatically. Block polling rates are defined by scanning blocks at the rate of the fastest tag scan rate in the block.

## Part Number :

**KEPS-KEP1-32:** KEP RS232 for SUPERtrol 1, SUPERtrol 1LE, SUPERtrol 2 and LEVELtrol 2 • 32 Bit DDE Server, Now with Modem Support

**KEPS-MBS32:** SUPERtrol & LEVELtrol Series with RS-485 & MODBUS RTU Support

## Supported Devices

- Multidrop Supported
- SUPERtrol ILE , SUPERtrol I, SUPERtrol II, LEVELtrol II, MS716, MS748, ES747

## Supported Data

KEPware's 32 bit KEP SUPERtrol device driver supports: Process Variables, Totalizers, Error Status, and Action Routines may be read or activated.

**Process Variables:** Heat, Mass, Corrected Volume, Volume, Temperature, Pressure, Density and similar items as well as Raw Input & Output signals.

**Totalizers:** Resettable & non-resettable total of: Heat, Mass, Corrected Volume and Volume

**Action Routines:** Initiate Print, Clear Totalizer, Clear Alarms, Start Batch, Stop Batch and many others

**Data Types:** Boolean - bit, Word - unsigned 16 bit, Short - signed 16 bit , Long - signed 32 bit  
DWord - unsigned 32 bit, Float - floating point 32 bit, Double - floating point 64 bit,  
String - null terminated ASCII

## Driver System Requirements

- Windows 95 and Windows NT 3.51 or better with 16MB RAM minimum.

## Network Configuration Options

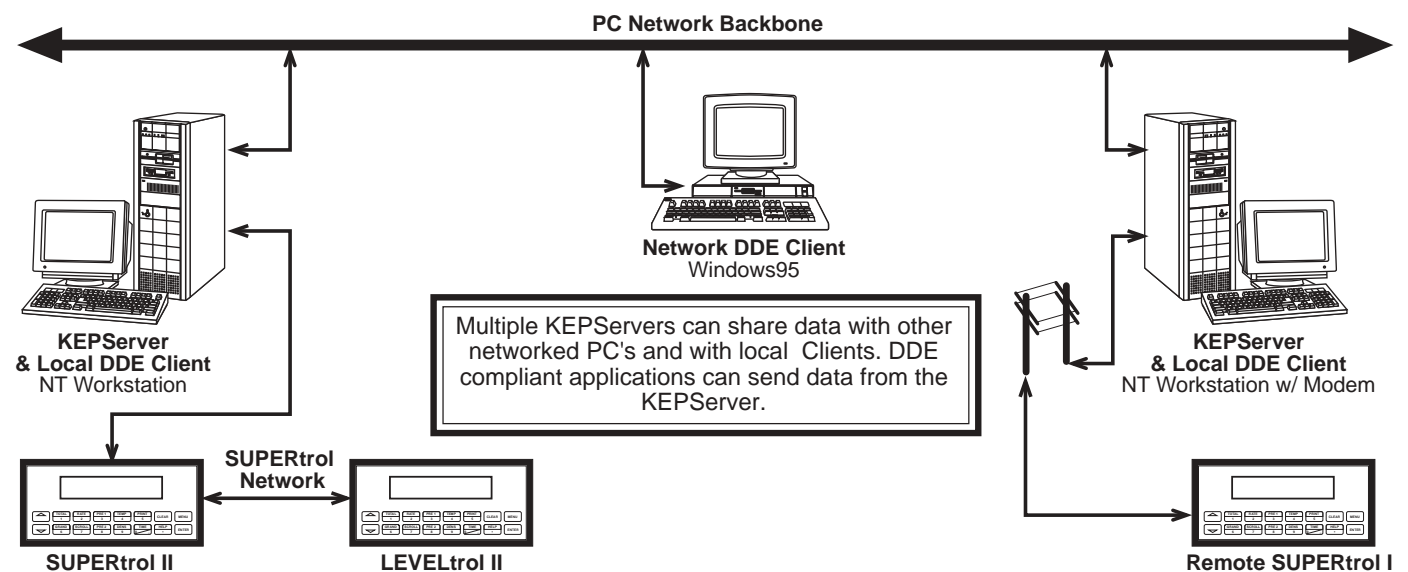

# TROLlink

## Remote Metering and Data Collection Software

### Features

- Retrieve data from KEP flow computers using direct wire, internet or modem connection.
- Collects data from the following Kessler-Ellis Products flow computer instruments: SUPERTROL I, SUPERTrol II, ES-747, LEVELTROL II, MASSTROL, DPFC
- Runs on: Windows 95® and higher; Windows NT® 4.0 and higher
- Works with most Hayes compatible modems for remote data collection.
- Handles a mix of instruments, they don't have to be the same type.
- Select the data items to acquire by simple check boxes for each instrument.
- Manual and automatic data collection modes.
- Can automatically collect data from 1 to 100's of instruments.
- Automatic data collection by Time and Date.
- Automatic Telephone busy retries.
- Collected data can go to screen, text file, Excel spread sheets and is available to DDE aware applications.
- Each instrument can have data directed to separate or common named files.
- Can write log files showing data collection session details and connection failures due to busy or no answers.
- Collects data from items that are displayable on instrument displays.
- Collects data from SUPERTrol and LEVELtrol II dataloggers.
- Automatic Peak Demand reset capability possible when using meter reading routes
- Each instrument can be assigned a route number to write special messages during data collection to data file.



### Description

TROLlink is remote metering software for collecting data, via direct wire or modem, from KEP's SUPERTrol, LEVELtrol II, MASStrol, and DPFC flow computer families.

This practical data collection system lets the operator retrieve data from one or hundreds of instruments, of varying types, in manual or automatic mode. Adding a modem and PC provides an easy-to-use and cost-effective remote monitoring system for utility, continuous process, and batching operations.

TROLlink's simple user interface prompts the operator to select the data items to be acquired, specify automatic data collection by time and date, direct data to screen, text, or EXCEL files, and define a route number for each instrument, if required.

TROLlink runs on Windows 95 and higher, and Windows NT 4.0 and higher, and works with most Hayes compatible modems.

# EASY TO SETUP!

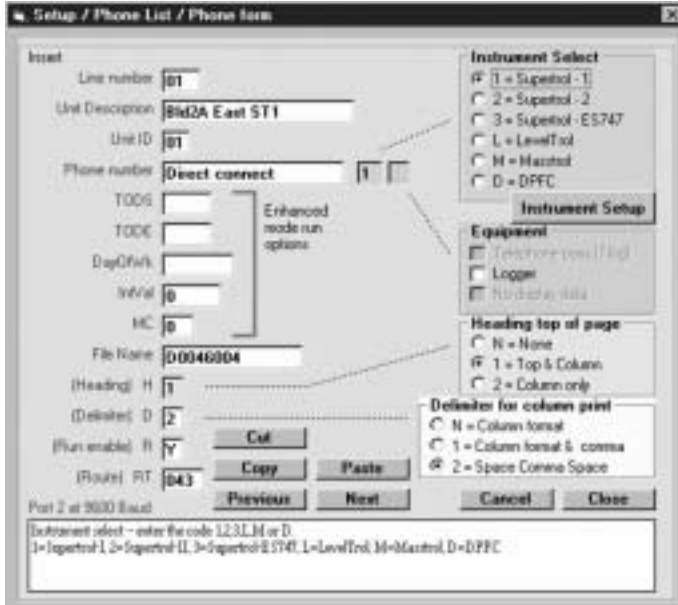

Setup is simple using check boxes and "fill in the blank" formats.

# EASY TO USE!

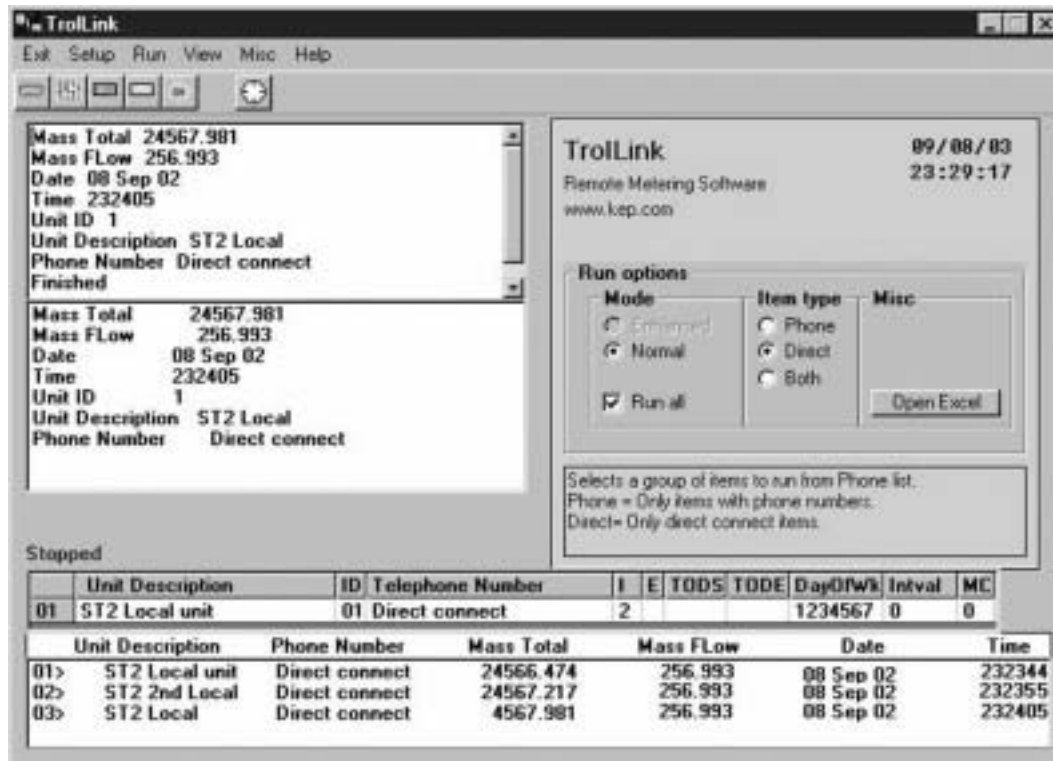

Within moments after setup you will be up and running and collecting your vital data. The data may be viewed on screen or saved as text or Excel™ Spreadsheet files

# IEPS 1000

## Intelligent Ethernet Single Port Server

### Features

- LAN-Attached Serial Port Expansion
- Optional Ethernet Hub
- Remote Monitoring
- IP Routing for Multi-Site Networks
- Software for Virtual Com Port Included
- Permits Gateway Connection from Instrument's RS-232 to PC's Ethernet LAN

### Description:

The IEPS1000 gives users the ability to connect KEP products with Ethernet networks. The SUPERtrol II (ST2) unit can be connected to the RS-232 port on the IEPS1000. The port server allows customers to use their existing plant 10 base T ethernet rather than running separate cables to the ST2's. This will permit users to have Infilink-HMI software, Server software or Flow Computer setup application running on a PC with an ethernet port. Their software at the PC end creates a virtual RS-232 COM Port for these programs.

### Port Server Software Included to:

- Assign IP Address
- Set Communication Parameters
- Create Virtual Com Port

The IEPS1000 Series of Networked Peripheral Servers provide LAN-attached serial port expansion and remote monitoring. The IEPS1000 is targeted to users who need to manage, control, and share access with one to two peripheral devices over the LAN or Internet using standard protocols. The IEPS1000 uses industry standard TCP/IP, and telnet protocols to ensure open-systems connectivity and flexibility for your demanding applications. The IEPS1000 is bundled with NativeCOM port redirection software, web browser interface, and remote diagnostics. NativeCOM simplifies installation and support, and makes any LAN-attached serial port (whether local or remote) appear as local to your Windows application.

### Typical Application

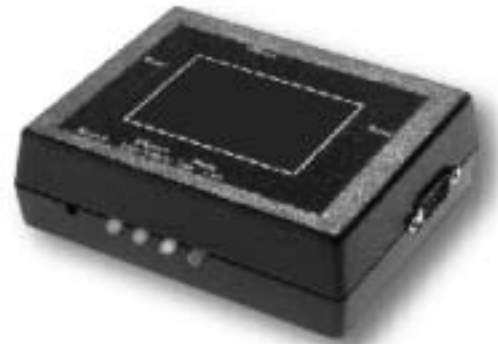
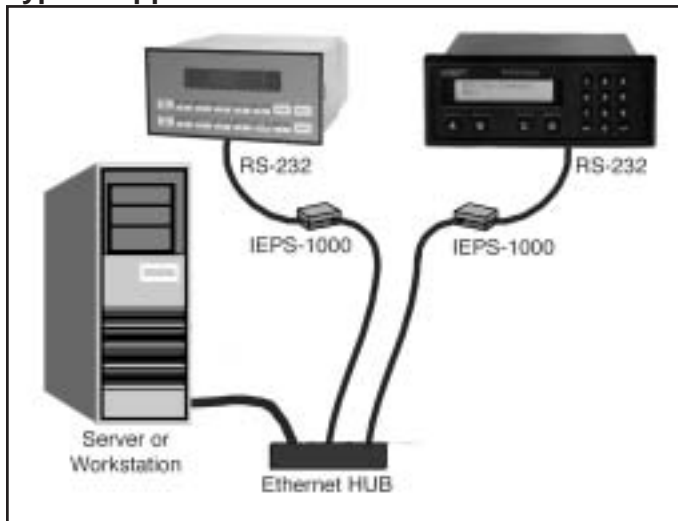

### SPECIFICATIONS

**Serial Interface:** DB9 Connector; supports all TTY signals (RxD, TxD, RTS, CTS, DCD, DTR, DSR, RI)

### Power Requirements:

External 110/220V; Worldwide; Over current protection

**Dimensions:** w 3.25" x l 4.37" x h 1.5"

**Temperature:** Operating temp 0° to 60° C

**Humidity range:** 5% to 95% non condensing

**LAN Interface:** RJ45 (10 Base-T), 10Mbit, Ethernet 802.3; TCP protocol

### Host Communications:

10 Base-T, 10Mbit, Ethernet 802.3

### Protocols Supported:

Raw TCP, NativeCOM port redirector, Telnet, Rtelnet, LPD

### Security:

Password protected configuration

### Management and Diagnostics:

Web-based interface, Remote/local diagnostics (to pin level)

### Compatible Instruments:

SUPERtrol 1LE, 1, 2, LEVELtrol II, INT69, MINItrol and others.

### Compatible Software:

SUPERtrol Family Setup Diskette, KEPServer, TROLlink, Infilink-HMI

### Ordering Information

IEPS1101 1-port, RS-232 Interface



# IEPS 3000

## Intelligent Ethernet Port Server

### Features

- LAN-Attached Serial Port Expansion
- Optional Ethernet Hub
- Remote Monitoring
- IP Routing for Multi-Site Networks
- Software for Virtual Com Port Included
- Permits Gateway Connection from Instrument's RS-232 to PC's Ethernet LAN

### Description:

The IEPS3000 gives users the ability to connect KEP products with Ethernet networks. Up to six SUPERtrol II (ST2) units can be connected to each of the RS-232 ports on the IEPS3000. The port server allows customers to use their existing plant 10 base T ethernet rather than running separate cables to the ST2's. This will permit users to have TROLlink, Infilink-HMI software, Server software or Flow Computer setup application running on a PC with an ethernet port. Their software at the PC end creates a virtual RS-232 COM Port for these programs.

Since the IEPS3000 works using an IP address and uses TCP/IP Protocol, it also has Internet address capabilities.

### Port Server Software Included to:

- Assign IP Address
- Set Communication Parameters
- Create Virtual Com Port

The IEPS3000 is characterized by high reliability, superior software functionality, expanded hardware interfaces and simplified remote installation. The IEPS3000 is designed for users who need to manage, control, program and share access with one to four devices over the LAN or Internet using standard protocols.

### Ordering Information

IEPS3182	2-port
IEPS3282	2 port with optional HUB port
IEPS3184	4-port
IEPS3284	4 port with optional HUB port



### IEPS3000 Hardware Specifications

- Motorola MC68EN360 QUICC 25 MHz or 33 MHz microprocessor with internal RISC processor.
- 1M byte in-circuit boot flash and program memory.
- 4 M byte nonparity DRAM.
- 10 Mbps Ethernet connection over 10BASET physical lines.
- 1 10BASET Ethernet HUB ports
- Two or Four asynchronous serial ports with modem control and surge suppression. Asynchronous port data rates of 50 bps to 115.2 Kbps over EIA-232 electrical interface. Uses DB-9 physical interface. Supports RS-232, RS-422, and RS-485.
- External 110 or 240 VAC power supply.
- Initialization self-test.
- Hardware exerciser.
- Status LEDs for each port.

### Environmental Specifications

Operating temperature range: 0 to 50°C  
Storage temperature range: -10 to 70°C  
Humidity range: 10% to 90% noncondensing

### Product Dimensions

The IEPS3000 model measures: 8 inches x 4.75 inches x 1.25 inches (203 mm x 121 mm x 32 mm)

### Ethernet cabling specifications

This section describes guidelines for using 10BASET twisted-pair cabling:

- Recommended cable is 22 to 26 AWG category 3 or category 5 unshielded solid copper twisted pair (standard telephone wire), at least Level 2 (two twists per foot).
- Maximum distance of a segment—from concentrator to node—is 100 meters (328 feet).
- Maximum of two devices to a cable segment.
- Ethernet network interface cards (NICs) are available with built-in 10BASET transceivers and a 15-pin AUI port.
- Devices with standard AUI ports may be attached by using a twisted-pair transceiver (MAU).

### Compatible Instruments:

SUPERtrol 1LE, 1, 2, LEVELtrol II, INT69, MINItrol and others.

### Compatible Software:

SUPERtrol Family Setup Diskette, KEPServer, TROLlink, Infilink-HMI

# CA-285

## RS-422/485 to RS-232 Interface Converter

### Features

- User Selectable RS-422 or RS-485
- RS-485 User Selectable 2 or 4-Wire Operation
- Intelligent Control of RS-485 Transmitter and Receiver
- Td and Rd LED
- DTE/DCE Compatible
- Data Rates up to 64k BPS
- Connects to Standard PC Compatible 25 Pin RS-232 Port

### DESCRIPTION:

The CA-285 is a unique interface converter that can be configured by the user to convert either RS-422 or RS-485 to RS-232. When operating in RS-485 mode, the CA-285 has an "intelligent" mode which provides control of the RS-485 line.

When configured to operate as an RS-232 to RS-422 interface converter, the CA-285 converts full duplex data, Td and Rd, between RS-232 and RS-422.

As an RS-232 to RS-485 converter, the unit can be configured for either 2 or 4-wire operation. In either mode, the CA-285 allows control of the transmitter so that multi-dropped operation can be accommodated. The CA-285 can be configured to control its data flow in one of two ways. The first is via the use of RTS, pin 4, of the RS-232 port. In this case, the RS-485 transmitter will turn ON when RTS is turned on. When RTS is OFF, the CA-285 is in the receive mode. In the 4-wire mode, the receiver is always on. The second method of controlling the RS-485 transmitter is to turn it on when Td data is applied to the RS-232 port. (recommended with KEPServer)

The receiver also operates differently depending on whether the mode is 2 or 4-wire. In the 2-wire mode, when no data is received by the RS-232 receiver, the RS-485 receiver is switched ON. When data is detected for transmission, the receiver is switched OFF. In the 4-wire mode, the RS-485 receiver is constantly ON while the transmitter is switched as required.

The CA-285 is equipped with a five position dip switch that is used to select the following:

RS-422 mode: 4-wire  
RS-485 mode: 2-wire  
RS-485 mode: 4-wire  
RS-485 mode: controlled by RTS  
RS-485 mode: controlled by data  
220 ohm terminator: in or out

The CA-285 is also equipped with a DTE/DCE switch to allow reversing pins 2 and 3 on the RS-232 interface. Td and Rd LED indicators help verify operation.



### SPECIFICATIONS:

<b>Interface:</b>	RS-232, conforms to CCITT V.24; pins 2 and 3 (transmit/receive data) switch selectable, pin 4 (RTS) tied to pin 5 (CTS), pins 6 (DSR), 8 (DCD) and pin 20 (DTR) are connected together; RS-422 or RS-485, selectable
<b>Connectors:</b>	RS-232, DB-25 male, RS-422/485, 5-position terminal block
<b>Indicators:</b>	2 LEDs, Td and Rd
<b>Switches:</b>	DTE/DCE switch selectable for reversing Td and Rd; 5-position dip switch set RS-422/485 operation and termination
<b>Data Rate:</b>	0 to 64k bps
<b>MTBF:</b>	596,000 hours
<b>Power:</b>	115 VAC at 60 Hz (Wall plug power adapter with 6' cable provided)
<b>Size:</b>	0.875"H x 2"W x 3.5" D
<b>Operating Temp.:</b>	32 to 122°F (0 to 50°C)
<b>Humidity:</b>	5 to 95% RH (non-condensing)

### Ordering Information

EXAMPLE      CA285  
Series      \_\_\_\_\_

CA-285 RS-422/485 to RS-232 Communication Adaptor

# MPP-2400

## Low Power Modem 2400 Baud Rate

### Features

- Operates on All Telephone Lines
- External DC Power Required
- 2400 BPS Operation
- Automatic Fallback
- Compatible with All Communications Software Including: TROLink Remote Metering Software
- Compatible with SUPERtrol 1LE, 1 & 2, LEVELtrol II Families
- Automatic Answer
- Tone & Pulse Dialing
- Compact Size

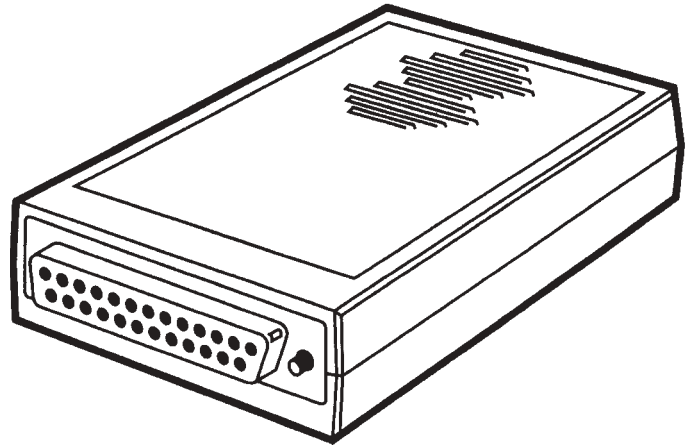

### Description:

The MPP-2400 Modem is ultra-compact and easy to install. The Modem operates at speeds up to 2400 bps. If you are connected to a slower speed modem on the other end of the line, the MPP-2400 automatically "falls back" to match the speed of the slower modem so your data transmission is not interrupted.

The MPP-2400 also features automatic answer, so it can operate unattended.

It will operate over rotary or push-button lines since it works in tone or pulse dialing modes.

The Modem is very small and simple to install. It offers a standard DB25 female connector for your RS-232 port connection and an RJ-11 jack for your telephone cabling.

The MPP-2400 complies fully with the Hayes Standard AT Command Set and the ITU V.22 bis and V.22 standards, as well as Bell 103 and Bell 212A protocols. The MPP2400 can be powered by ST1LE, ST1, ST2 and LT2 units equipped with modem power option (option "M")

Alternately, an external DC power supply is available upon request. Call factory for details.

### SPECIFICATIONS:

<b>Operation:</b>	Full- or Half-Duplex
<b>Standards:</b>	ITU V.22, V.22 bis, Bell 103/212A
<b>Interface:</b>	RS-232/V.24
<b>Baud Rate:</b>	2400, 1200, 300 bps
<b>Command Set:</b>	AT compatible
<b>Dialing:</b>	Tone and Pulse
<b>Transmit Level:</b>	-12 dBm
<b>Receive Sensitivity:</b>	-70 dBm
<b>Dropout Level:</b>	-43 dBm
<b>Operating Temp.:</b>	32 to 104 °F (0 to 40 °C)
<b>Storage Temp.:</b>	-40 to 212 °F (-40 to 100 °C)
<b>Humidity:</b>	10 to 95% (non-condensing)
<b>Connectors:</b>	(1) DB25 female, (1) RJ-11 female
<b>Power:</b>	6.5 to 15 VDC (75mA) Pin 20 (+); Pin 7 (-)
<b>Size:</b>	0.9"H x 2.3"W x 3.4" D
<b>Weight:</b>	0.18 lb. (0.08 kg)

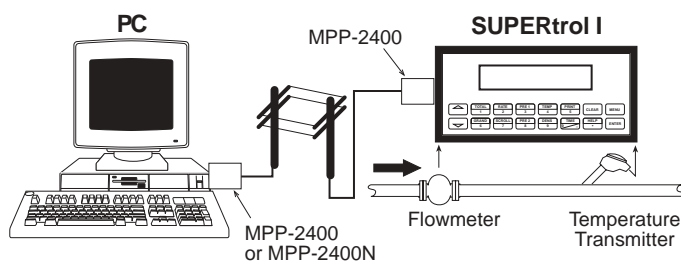

### Ordering Information

EXAMPLE MPP2400

Series

MPP-2400 Low Power Modem

### Accessories

Interconnecting Cables and Power Pack Available on Request

# MS-722 MPP-2400N

## Wall Mount External Modem

### Features

- Operates on All Telephone Lines
- RS-232 Powered from SUPERtrol-II
- 2400 BPS Operation
- Automatic Fallback
- Compatible with All Communications Software Including: TROLink Remote Metering Software
- Compatible with SUPERtrol 1LE, 1 & 2, LEVELtrol II Families
- Automatic Answer
- Tone & Pulse Dialing
- Wall Mount Enclosure with Locking and Sealing Provisions
- FCC Approved



### Description:

The MS722MPP-2400N Modem is compact and easy to install. It needs no batteries or AC power because it's designed to run on the DC power provided from the SUPERtrol (with modem power option "M") interface to which it attaches.

The Modem operates at speeds up to 2400 bps. If you are connected to a slower speed modem on the other end of the line, the MPP-2400 automatically "falls back" to match the speed of the slower modem so your data transmission is not interrupted.

The MS722MPP-2400 also features automatic answer, so it can operate unattended.

It will operate over rotary or push-button lines since it works in tone or pulse dialing modes.

The Modem is very small and simple to install. It offers an RJ-45 connector for your RS-232 port connection and an RJ-11 jack for your telephone cabling. An extra RJ-11 jack is provided to permit the connection of a portable telephone.

The MS722MPP-2400 complies fully with the Hayes Standard AT Command Set and the ITU V.22 bis and V.22 standards, as well as Bell 103 and Bell 212A protocols.

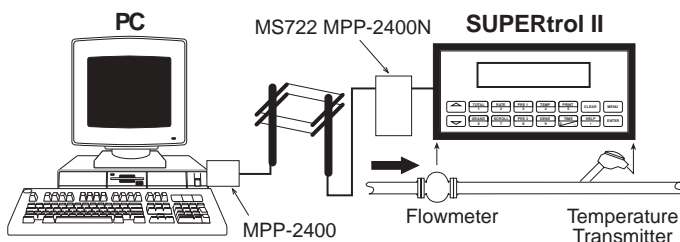

### SPECIFICATIONS:

<b>Operation:</b>	Full- or Half-Duplex
<b>Standards:</b>	ITU V.22, V.22 bis, Bell 103/212A
<b>Interface:</b>	RS-232/V.24
<b>Baud Rate:</b>	2400, 1200, 300 bps
<b>Command Set:</b>	AT compatible
<b>Dialing:</b>	Tone and Pulse
<b>Transmit Level:</b>	-12 dBm
<b>Receive Sensitivity:</b>	-70 dBm
<b>Dropout Level:</b>	-43 dBm
<b>Operating Temp.:</b>	32 to 104 °F (0 to 40 °C)
<b>Storage Temp.:</b>	-40 to 212 °F (-40 to 100 °C)
<b>Humidity:</b>	10 to 95% (non-condensing)
<b>Connectors:</b>	(1) RJ-45, (2) RJ-11 female
<b>Power:</b>	7-12VDC (RS-232 pins 8 & 9, 75mA)
<b>Size:</b>	8.97" H x 7.86" W x 5.38" D
<b>Weight:</b>	1 lb.

### Ordering Information

EXAMPLE MS722MPP2400N  
Series

MS722MPP-2400N Wall Mount, External Modem

# MPP-2400N

## Wall Mount External Modem

### Features

- Operates on All Telephone Lines
- RS-232 Powered from KEP Instruments
- 2400 BPS Operation
- Automatic Fallback
- Compatible with All Communications Software Including: TROLink Remote Metering Software
- Compatible with SUPERtrol 1LE, 1 & 2, LEVELtrol II Families
- Automatic Answer
- Tone & Pulse Dialing
- Compact Wall Mount Enclosure
- FCC Approved

### Description:

The MPP-2400N Modem is ultra-compact and easy to install. It needs no batteries or AC power because it's designed to run on the DC power provided from the SUPERtrol interface to which it attaches.

The Modem operates at speeds up to 2400 bps. If you are connected to a slower speed modem on the other end of the line, the MPP-2400N automatically "falls back" to match the speed of the slower modem so your data transmission is not interrupted.

The MPP-2400N also features automatic answer, so it can operate unattended.

It will operate over rotary or push-button lines since it works in tone or pulse dialing modes.

The Modem is very small and simple to install. It offers a standard DB-9 male connector for your RS-232 port connection and an RJ-11 jack for your telephone cabling.

The MPP-2400N complies fully with the Hayes Standard AT Command Set and the ITU V.22 bis and V.22 standards, as well as Bell 103 and Bell 212A protocols.



### SPECIFICATIONS:

<b>Operation:</b>	Full- or Half-Duplex
<b>Standards:</b>	ITU V.22, V.22 bis, Bell 103/212A
<b>Interface:</b>	RS-232/V.24
<b>Baud Rate:</b>	2400, 1200, 300 bps
<b>Command Set:</b>	AT compatible
<b>Dialing:</b>	Tone and Pulse
<b>Transmit Level:</b>	-12 dBm
<b>Receive Sensitivity:</b>	-70 dBm
<b>Dropout Level:</b>	-43 dBm
<b>Operating Temp.:</b>	32 to 104 °F (0 to 40 °C)
<b>Storage Temp.:</b>	-40 to 212 °F (-40 to 100 °C)
<b>Humidity:</b>	10 to 95% (non-condensing)
<b>Connectors:</b>	(1) DB-9 male, (1) RJ-11 female
<b>Power:</b>	7-12VDC (RS-232 pins 8 & 9, 75mA)
<b>Size:</b>	3.0"H x 5.1"W x 2.4" D
<b>Weight:</b>	0.5 lb.

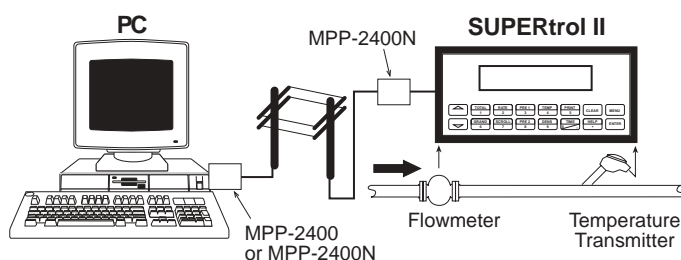

### Ordering Information

EXAMPLE MPP2400N

Series

MPP-2400N Wall Mount, Port Powered Modem

### Accessories

Interconnecting Cables and Power Pack Available on Request

# TWP

## Industrial Two Way Pager Wireless Data Transceiver

### Features

- Use ST2 and TWP to Automatically Send Meter Readings by Email
- Wireless Communications Over ReFLEX Two Way Paging Network
- Request Information From SUPERtrol II on Demand, by Exception or on a Scheduled Basis
- Low Cost Solution for Moderate Message Lengths
- Up to 500 Bytes of Data per Transmission

### APPLICATIONS:

Remote Wireless Metering Applications  
Fixed Telemetry  
Call Out/Call In capabilities to a host system

### DESCRIPTION:

The TWP is a two way wireless data transceiver intended for applications where ReFLEX Two-Way Wireless Messaging will be used in remote metering applications using SUPERtrol II flow computers.

The TWP is intended for fixed telemetry applications requiring moderate message length wireless communications.

TWP can initiate a transmission as well as receive and store a transmission. Messages are loaded/sent and received/read using a RS-232 Port and CLP communication linking protocol commands.

### USER WIRING TERMINATIONS:

RS-232 Port Pin Assignment

- |   |                |
|---|----------------|
| 1 | DO NOT USE     |
| 2 | RECEIVE (IN)   |
| 3 | TRANSMIT (OUT) |
| 4 | DO NOT USE     |
| 5 | SIGNAL GROUND  |
| 6 | DO NOT USE     |
| 7 | BIAS           |
| 8 | DC POWER -     |
| 9 | DC POWER +     |

### Ordering Information

EXAMPLE	TWP	N	W	6ST2
Series	TWP = Two Way Pager			
Enclosure	N = NEMA4X			
Antenna Type	W = Internally mounted Dipole Whip (std) R = Internal Radome with 5' Antenna Cable			
Interconnecting Cable	6ST2 = 6 foot ST2 Cable (other lengths available)			
Accessories	TWP-AMK = Antenna Mounting Kit for Radome Antenna			



- Confirmed Message Delivery
- Check Meter Readings Over Internet or Pager

### SPECIFICATIONS:

Antenna:	Internal Dipole antenna Optional External Antenna and Antenna Mounting Kit Accessory (or customer supplied)
Antenna Connection:	External Female SMA Connector
Transmitter Specifications	ReFLEX NBPCS Networks (901-902MHz)
Frequency	1.75 – 2.0 Watt
RF Power Output at Antenna Port	ReFLEX 25 9600
Transmit Data Bit Rate	ReFLEX 50 9600
Frequency Stability	1 ppm on transmit
Receiver Specifications	929-942 MHz
Frequency	6400 bps
Receive Data Bit Rate	-115 dBm
Receiver Sensitivity	
Serial Input Connection:	DB9-M
Connector:	RS-232 with power connection
Electrical:	Motorola CLP – Communications Linking Protocol
Protocol:	
Power Consumption:	7-12 VDC
Primary Voltage:	6 VDC Sealed Battery
Standby/Transmit Power:	50 mA
Standby Operation	150 mA
Receive	1.5 A
Transmit	Rechargeable battery provided
Battery	
Reverse Polarity Protected	
Overcurrent Protected	
EMC filtered	
Environmental:	
Enclosure Rating:	NEMA-4X
Dimensions:	3.5" x 4.75" x 8"
Operating Temperature:	0 to +70C
Storage Temperature:	-40 to +85C
Humidity:	0-95% Non Condensing
Approvals:	FCC
Mounting Cautions and Hazards:	Mount antenna in a location where people will not come within 12" during use

# Factory Automation Solutions Tutorial

The selection of factory automation hardware and software is a topic still quite new to many users of conventional flow instrumentation. They are presented with a increased range of possible solutions to their plant wide automation needs.

Broadly speaking there are three basic approaches to solve instrumentation and control needs. These are networks of instrumentation, or PLC based designs, or PC based designs. Each has its own merits based on the size of the plant and the need for local control.

Industrial PC's are finding their way into more and more monitoring and control applications each year. In most cases the PC is used as an operator station or data gathering station which collects information from a number of instruments or PLC's.

Many users are trying to grow their own system by looking at their need for information and tackling small portions of their plant one step at a time and slowly adding these to their existing PC network within their plant.

**How will information be displayed on my PC?** Generally speaking there are two broad mechanisms which are involved in the display of factory information on a PC. One program is gathering and sharing data with the display, or "client" program. The data gathering program is called a "Server/Driver". "Client" programs include "HMI" or Human Machine Interface programs and common PC Spread Sheet and/or Database report programs. Many are available on the market.

**How do I select an Industrial PC?** In most cases the hardware selection is done after you have decided on the software, on what you want this to do, and how it will be connected to the rest of the plant. Many experts agree that you should purchase a PC which is compatible with your software and with the best capabilities you can afford. Industrial PC offerings change frequently.

**What are some of the selection criteria for Industrial PC's?** Most customers begin by reviewing the processor, memory and hardware requirements for the software they plan on using since this lists the minimum requirements for any PC they might use. Next the desired display type/size, operator input, environmental ratings, and materials of construction are reviewed. The number and type of required field and/or instrument communication channel and the desired network connection is also considered. Supplier quotations are then solicited.

**What are the common field or instrument communication channels?** There has been a lack of standardization in instruments and PLC's. There are many on the market and in most plants. As a result it is not uncommon to find that several communication ports are required on your PC. Industrial PC's are usually provided with 2 or 4 RS-232 serial com ports and an optional LAN connector. Instruments and PLC's are arranged into groups that share a communication channel hardware and protocol type. Each com port is then associated with a "Server" software that knows how to gather information over that channel and how to share that information with the "client" software which is running on that or remote PC's. In some cases a "signal adapter or converter" is required to convert the COM Ports RS-232 into the signal type required by that channel. An example might be a RS-485 communication channel with several instruments which uses the MODBUS-RTU protocol would connect to COM PORT1 using a RS-232 to RS-485 adapter.

**What are the common office LAN connections used in business?** It is important to note that an industrial PC is after all a PC. Your system administrator will add a network card and software in the same manner as other PC's in your office. Many Industrial PC's come with an Ethernet connection as standard or as a option.

## Typical Application:

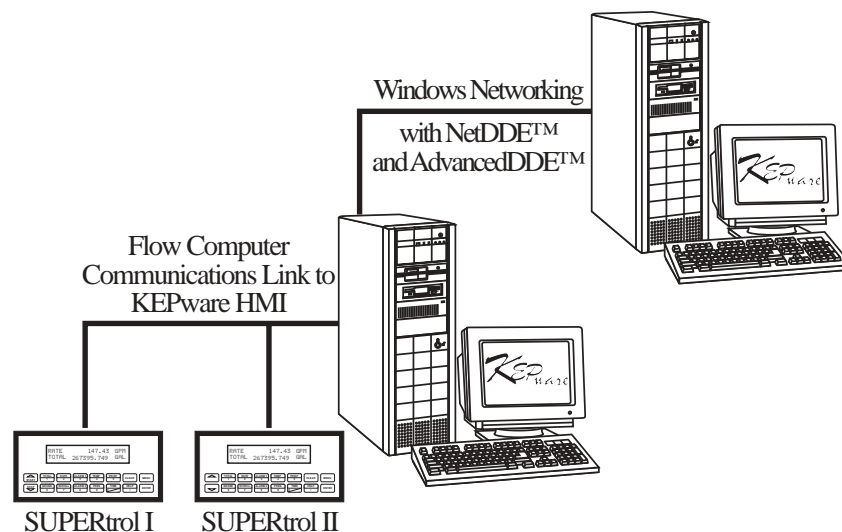

# INFILINK-HMI

## Industrial Automation Software

### Features

- Free Design Mode: Only pay to unlock run-mode copies
- OPC Client Functionality
- E-mail and Web Enabled: Send e-mail and View tag data over the Internet

### Description:

Infilink-HMI is a full featured solution at an affordable price. It is ideal for the small PLC user with its easy setup and run time price half that of competitive products. Machine builders and users want the benefits of a Windows based package, but are held back by the premium prices demanded by many vendors. Infilink-HMI changes all of that with the truly affordable HMI, Infilink-HMI.

### Features Added to the New Version of Infilink-HMI

- OPC Client Functionality
- E-mail and Web Enabled: Send e-mail and View tag data over the Internet
- Historical and Alarm Data Logging to MS Access (MDB) Files

### Other Important Features of Infilink-HMI:

- Free Design Mode: Only pay to unlock run-mode copies
- Historical Trending, Alarming, Data Logging included in base price
- Email and Web Enabling included in base price
- No yearly "maintenance" or "support" fees
- Built In Scheduler
- OPC, DDE, NetDDE & AdvancedDDE Support

### Email Capable

Infilink-HMI can send email messages based on alarm conditions. This can be a regular email message, or it could be sent to a technician's alphanumeric pager.



- Historical Trending, Alarming, Data Logging included in base price
- Email and Web Enabling included in base price
- No yearly "maintenance" or "support" fees

### Scheduler

Infilink-HMI now includes a built in scheduler. Events can take place or tag data can be changed based on time, date, day of week, or holiday.

New events can be entered by the operator in Run mode through the calendar interface.



### Infilink-HMI Communicates Using KEPServerEX

- One free driver included with Infilink-HMI purchase.
- OPC and DDE supported.
- Over 100 drivers available.
- Support for various fieldbus networks including Ethernet TCP/IP and DeviceNet.

### Web Enabled

Use the internet and our Infiviewer utility to view tag data. This is an especially powerful troubleshooting feature when combined with email going to an alphanumeric pager. Infilink can notify technical personnel of a problem via email, and give them the ability to obtain additional application information over the internet.





## Graphic Objects and Editing Features

Infilink-HMI provides a powerful set of graphic primitives and editing features allowing you to easily depict your application's displays. All of these functions are available from our toolbox. Store your objects in libraries for reuse later or use the 2000+ library objects available with Infilink-HMI to speed your development.

### Professional Library Objects

Infilink-HMI includes over 2000 professionally drawn library objects licensed from Reichard Software, famous for their Symbol Factory product. Additionally, our libraries also contain hundreds of pre-animated objects such as buttons, meters, displays, and sliders to a name few. These pre-animated objects can quickly be added to your application using the new Reassign Tags function. Drag and Drop objects out of the library into your application.

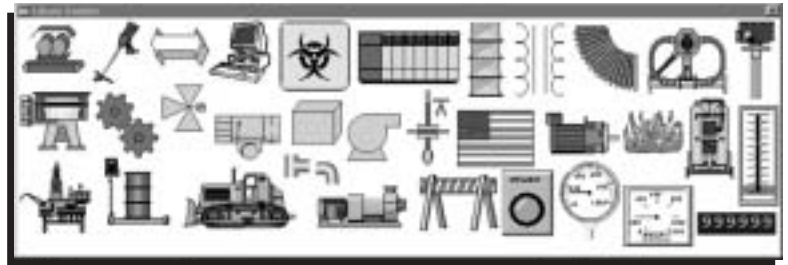

Arrange your toolbars on the top, bottom, middle, or sides of the screen with Floating Palettes.

### Key Editing and Drawing Functions Include:

- Lines
- Polylines
- Polygons
- Rectangles
- Rounded Rectangles
- Ellipses & Circles
- Arcs, Pies, Chords
- Text
- Bitmaps
- Buttons
- Windows Metafile Import
- Alarm Displays
- Alarm Logger
- Trend Displays
- Object Grouping
- Editing of Group Objects
- Align ~ Left, Right, Top, Bottom
- Align Middle ~ Horizontal, Vertical
- Space Equal ~ Horizontal, Middle
- Rotate ~ Clockwise, Counter Clockwise
- Make Equal ~ Width, Height
- Bring to Front
- Send to Back
- Z Depth Level 1-10
- Reshape
- Rotate Shapes
- Flip Horizontal or Vertical

### Key Animation

#### Functions Include:

- Visibility ~ Show/Hide
- Change Color
- Blink ~ Fast, Medium, Slow
- Take Action ~ Activate Script
- Rotate Shapes
- Move ~ Horizontal, Vertical
- Stretch ~ Horizontal, Vertical
- Enter Data ~ Boolean, Numeric, String
- Slider ~ Horizontal, Vertical
- Show Value ~ Boolean, Numeric, String

### Trend Functions

Infilink-HMI provides built-in Real Time and Historical Trend objects which allow you to quickly add time based views of your process data.

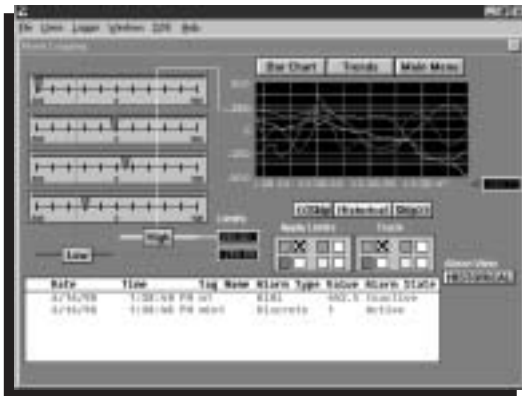

Sample Trending Application

### Scripting Language

Infilink-HMI was designed to fit all of your needs with our built in functions. However, we have provided a powerful scripting language allowing you to tailor Infilink-HMI's operation to meet any application requirement.

### Key Script Functions Include:

- Project Script ~ (Before, While, After) Open
- Window Scripts ~ (Before, While, After) Open
- Tag Scripts ~ On Data Change
- Conditionals ~ IF, THEN, ELSE
- Logical Operators ~ AND, OR, NOT
- Comments
- File Functions ~ Read, Write, Text, CSV
- Object Property Access
- Conditional Operators
- Full Set of Math and String Functions
- Automatic Error Checking
- Play Wave Files

### Data Logging

Any Tag in Infilink's tag database can be configured to log itself to disk. Crucial events can be stored and shared with any application via industry standard database formats.

### Key Data Logging Functions Include:

- User Specified Logging Path
- User Controlled Log Enabling
- Log File Change Based On Time
- Improved logging performance
- User Selectable DBASE (DBF) or MS Access (MDB) file formats.



## Alarm Management and Display

Infilink-HMI provides a complete alarm management and display system available from any window in your application. Operators can view and acknowledge alarm conditions quickly using the alarm object. The Alarm History Viewer allows logged alarm events to be searched and filtered.



### Key Alarm Functions Include:

- Limit Alarms ~ LowLow to HighHigh
- Discrete Alarms
- Selectable Priority Levels
- Custom Alarm Messages
- Selectable Filtering on History Viewer
- Automatic Printing of Alarms
- Logging of event with User ID
- Print Selected Alarm History Data

### MS Access (MDB) File Logging

Use your favorite editor or report generation tools such as Excel, Crystal Reports or MS Access, to organize or analyze your data.

### OPC Client

OPC (Object Linking and Embedding for Process Control) is now the standard format for industrial communication drivers. We have added OPC Client functionality to Infilink-HMI. Now you can use any of the OPC communication servers on the market with our product. We recommend using the KEPSWare Extreme OPC servers, but you can use the OPC server product of your choice. Infilink also supports AdvancedDDE and NetDDE.

### Other Features:

#### Software Based Protection

Infilink-HMI uses a software based keying system which works on any Windows operating system.

#### Multi-Platform Operation

Infilink-HMI runs with Windows 98SE, Windows 2000 and Windows NT.

## Minimum System Requirements

Pentium 133MHz CPU  
32 MB of RAM  
50 MB of Free Disk Space  
Display Resolution of 640x480 Run Mode, 800x600 Design Mode

## Free Development System

### Buy Only the Runtimes You Need

Infilink-HMI now offers our complete development system for free. When you download the latest version of Infilink-HMI (4.00 or higher) from our web site you have a complete development system. There's no limitation on the tag count. The provided runtime has a one hour expiration time. When used in combination with a demo version of our 32 bit OPC servers, you have a complete HMI system that can be used by every developer in your organization without spending a dime.

## Ordering Information

### Runtime Packages with the following Real I/O Tag counts are available:

128 I/O Tag Runtime **Part # KEPRUN-128**

includes 1 KEPServer driver

256 I/O Tag Runtime **Part # KEPRUN-256**

includes 1 KEPServer driver

512 I/O Tag Runtime **Part # KEPRUN-512**

includes 1 KEPServer driver

Unlimited I/O Tag Runtime **Part # KEPRUN-0000**

includes 1 KEPServer driver

Note: Internal or Memory tags are not counted as part of your licensed tag count.

Download a fully functional version of Infilink-HMI from our website at: [www.kep.com](http://www.kep.com)

# KEP ServerEX

## High Performance OPC Server Software

### Description

KEPServerEX is the latest generation of KEPware's OPC server technology. Building upon the original KEPserver, KEPServerEX has incorporated many of the features requested by KEPware's customers. In addition to customer driven enhancements, many technological changes have occurred. These features and enhancements have all been made with the goal of providing an OPC server that demonstrates unparalleled compatibility and performance. A few of the enhancements are transparent to the user, but there are a number of new features that are readily apparent and directly available to the user. The following sections will describe the primary features of KEPServerEX.

### Application Connectivity

KEPServerEX supports the following client server technologies:  
OPC Data Access Version 1.0a & 2.0  
DDE Format CF\_Text, XL\_Table & AdvancedDDE

### Device Connectivity

KEPServerEX allows you to use a number of communications drivers concurrently.

### Runs as NT Service

KEPServerEX supports running as a service under Windows NT/2000. Service operation is completely user configurable from the Tools|Options menu and can be changed at any time allowing you to move from normal stand alone program operation to NT service mode.

### Data Scaling

KEPServerEX now supports direct scaling of device data. Scaling allows raw device data to be converted to engineering units for OPC client applications. KEPServerEX provides a number of unique scaling features that make it easy to implement scaling in your application.



### On-Line Full Time

The full time on-line mode of operation allows a KEPServerEX project to be modified while the server continues to supply data to client applications. Almost every parameter can be changed while the server is operating.



### User Management

KEPServerEX includes a built-in User Manager that allows complete control over what types of functionality each individual user can access.

### Tag Management

KEPServerEX's new user defined tag management features allow you to create a tag database structure that fits the nature of your application.

### Automatic Tag Database Generation



The Automatic Tag Database Generation feature brings OPC technology one step closer to Plug and Play operation. Drivers that support this feature can either read tag information directly from a device or generate tags from stored tag data.

### Diagnostics

KEPServerEX's new diagnostic features provide real-time data on the performance of your communication driver. All read and write operations can be viewed in the diagnostic display window of KEPServerEX or can be tracked directly in your OPC client application by using its built-in diagnostic tags.

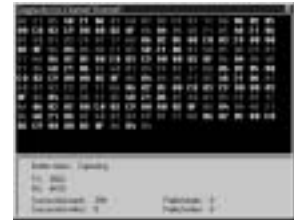

### Modem Support

KEPServerEX supports the use of modems on all serial communication drivers. Modem control is provided by a set of new modem tags.

### OPC Quick Client

KEPServerEX includes an extensive OPC Quick Client application to aid in the development of your OPC applications.



### Visual Basic Examples

The simple and complex VB examples included with KEPServerEX are well commented and provide additional pointers for using OPC servers in your VB applications.

### System Requirements:

	<u>Minimum</u>	<u>Recommended</u>
<b>Operating System:</b>	Windows 98	Windows NT 4.0 SP5 or better
<b>Processor:</b>	Pentium 200Mhz	Pentium 400Mhz
<b>Ram:</b>	32 MB	64 MB
<b>Disk Space:</b>	10 MB	10 MB

**NOTE:** While KEPServerEX will run on Windows 95 and Windows 98 we strongly recommend the use of either Windows NT 4.0 SP5 or Windows 2000 for use in industrial applications.

For More Information call KEPware, Inc.

KEPware • 81 Bridge Street • Yarmouth, Maine 04096  
Phone: 207-846-5881 • Fax: 207-846-5947 • <http://www.OPCSource.com>

# FLOWtrol *Batch Controller*

## Features

- Start/Stop Buttons and Remote Inputs
- Programmable K-Factor
- Batch Total and Grand Total
- Two DPDT Relay Outputs for Two Stage Shut Off
- Pulse Input to 20 kHz Count Frequency

## Description:

The FLOWtrol is a batch controller intended for use with pulse producing flowmeters. The FLOWtrol offers control outputs consisting of DPDT Relays rather than SPDT Relays. The Flowtrol may be applied in existing applications seeking to expand their batching operations with compatible units.

The FLOWtrol was the fore runner to the BATCHtrol II. However, it lacks the rate display, analog input and Easy Preset capabilities now available in the BATCHtrol II. The BATCHtrol II is recommended for all new applications.

## Specifications:

**Display:** 8 digit, .55" high, 15 segment bright LED.

### Input Power:

- A) 115 VAC ±15% or 12 to 27 VDC
- B) 230 VAC ±15% or 12 to 27 VDC

**Current:** 280 mA DC max. or 5.3 VA (5.3W) at rated AC voltage.

### Output Power: (on AC powered units only)

+12 VDC @ 100 mA and separate isolated 12 VDC @ 100 mA to allow ±12 VDC or + 24 VDC, regulated ±5% worst case.

### Input: (count/start/stop/reset)

- High: 3 to 30 VDC
- Low: open or <1 VDC
- Impedance: 10 kΩ
- Frequency: 20 kHz max.

Inputs: Positive edge triggered, 3 μsec/61 μsec/5 msec selectable debounce filtering.

### Control Output: (preset and prewarn)

DPDT relay, 5 amp, 115 or 230 VAC

**Temperature:** 32° to 132°F (0° to 55°C)

**Humidity:** 0 to 90% (non-condensing)

**Memory:** EEPROM stores all program and count data for minimum of 10 years if power is lost.

**Dimensions:** See BATCHtrol II

## Ordering Information

Example	FLO8	A	1
FLOWtrol	_____	_____	_____
<b>Operating Voltage:</b>	_____		
	A: 110 VAC ±15% or 12 to 27 VDC B: 220 VAC ±15% or 12 to 27 VDC		
<b>Options:</b>	_____		
	1: RS232 Serial Interface 2: RS422 Serial Interface		

## Accessories:

FLEXCOVER #36120

XTROL7/4- Explosion proof housing, see XTROL 7/4

NEMA 4X wall mount enclosure available, see NEMATROL

Serial printer available, see P1000, P295

Ethernet Port Server available, see IEPS

RS-422/485 to RS-232 Communication Adaptor available, see CA285

# KEPtrol F/C *Measures Net Flow of Boiler Fuel*

## Features

- Displays Net Rate & Net Total (A – B) or (A + B)
- Pulse Input to 10 kHz Count Frequency
- Separate K-Factors for A and B inputs
- Set Point Alarms
- NEMA 4X/IP65 Front Panel

## Description:

The KEPtrol F/C is a special version of the KEPtrol R/T designed to measure the net flow of boiler fuel. Separate K-Factors can be entered for A and B inputs. Two SPDT relay alarm outputs are standard. A scaled pulse output is standard for interfacing with remote devices. An analog output is available to interface with strip chart recorders.

## Specifications:

**Display:** 8 digit, .55" high, 15 segment bright LED.

### Input Power: (Internally Fused)

- A) 115 VAC ±15% or 12 to 27 VDC
- B) 230 VAC ±15% or 12 to 27 VDC

**Current:** 280 mA DC max. or 5.3 VA (5.3W) at rated AC voltage.

### Output Power: (on AC powered units only)

+12 VDC @ 100 mA and separate isolated 12 VDC @ 100 mA to allow ±12 VDC or + 24 VDC, regulated ±5% worst case.

The DC Outputs are supplied with self resetting fuses.

### Pulse Inputs:

- Thresholds: High: 3 to 30 VDC; Low: open or <1 VDC
- Impedance: 10 kΩ
- Frequency: 10 kHz max. (min. on/off 100 μsec.)

### Control Output:

- Open Collector: Sinks 250 mA max @ 30 VDC
- SPDT Relay: 10 amp, 115/240 VAC or 28 VDC

### Temperature:

32° to 132°F (0° to 55°C)  
ET: Extended Temperature -40° to 158°F (-40° to 70° C)

**Accuracy:** 100% over specified temperature range

**Humidity:** 0 to 90% (non-condensing)

**Memory:** EEPROM stores all data for min. of 10 years if power is lost.

**Dimensions:** See KEPtrol R/T

**Listing:** CE Compliant, UL/CSA Pending

## Ordering Information

Example	KFC8	A	3A	2	E	1	3
KEPtrol F/C	_____	_____	_____	_____	_____	_____	_____
<b>Operating Voltage:</b>	_____						
	A: 110 VAC ±15% or 12 to 27 VDC B: 220 VAC ±15% or 12 to 27 VDC						
<b>Control Inputs:</b>	_____						
	*3A: STD Pulse 3-30 VDC 20 kHz Max. *3B: As 3A, with 4.7 KΩ pull up resistors						
<b>Control Outputs:</b>	_____						
	1: Open Collector 2: SPDT Relay 10A						
<b>Input Speed:</b>	_____						
	*A: 0-40 CPS (Inputs 3A, 3B) *C: 0-400 CPS (Inputs 3A, 3B) *E: 0-10K CPS (Inputs 3A, 3B) *Dip switch selectable, all units can be field modified easily.						
<b>Options: (Multiple Options Available)</b>	_____						
	1: RS232 Serial Interface 2: RS422 Serial Interface 3: 4-20 mA Output (Input 3A or 3B only) 3X: 0-20 mA Output (Input 3A or 3B only) 3Y: 0-5VDC Output (Input 3A or 3B only) 3Z: 0-10VDC Output (Input 3A or 3B only) ET: Extended Temperature -40° to 158°F (-40° to 70° C) <b>ET not available with analog outputs</b> CSA: CSA Approved Unit (pending) ..... (consult factory)						

## Accessories:

FLEXCOVER #36120

XTROL7/4- Explosion proof housing, see XTROL 7/4

NEMA 4X wall mount enclosure available, see NEMATROL

Serial printer available, see P1000, P295

Ethernet Port Server available, see IEPS

RS-422/485 to RS-232 Communication Adaptor available, see CA285

# MASSbatch

## TEMP./DENSITY COMPENSATED BATCH CONTROLLER

### Features

- Display Mass or Corrected Volume, Rate, Grand Total, Temperature or Density
- Accepts 4-30V Inputs or Pulses Directly From Magnetic Pickup Meters (no pre-amp required)
- Takes a Direct 100Ω Platinum RTD or Analog Signal For Compensation Input
- RS232/422 Communications (optional)
- Scalable 4-20mA Output of Rate/Total



### Description:

Featuring 8 digits of bright, .55", alphanumeric display, the MASSbatch can accept up to 10,000 pulses per second and a direct 100Ω platinum RTD or analog input. The MASSbatch has two separate, 8 digit, floating decimal, "K" factors to convert the inputs to meaningful total and rate data. The user, with the push of a button, can toggle back and forth to view the total of the batch, the rate of flow, temperature or density and the grand total. Two control outputs are provided for two-stage valve control.

A scaled pulse output is also provided by an open collector driver. Since the output frequency is user selectable at 10, 200, 2K or 20K Hz, the unit can transmit the count data to remote electromechanical or electronic counters as well as computers, programmable controllers or other monitor equipment.

An optional analog output allows the user to select low and high settings to control strip recorders or other peripherals.

### Specifications:

**DISPLAY:** 8 Digit, .55" High, 15 Segment, Red Orange, LED.

**INPUT POWER:** (Internally Fused)

A: 110 VAC ±15% or 15 to 27 VDC

B: 220 VAC ±15% or 15 to 27 VDC

**CURRENT:** Maximum 350 mA DC or 8.8 VA (8.8W) at rated AC voltage.

**OUTPUT POWER:** (On AC powered units only):

+12 VDC at 100mA. Separate Isolated 12 VDC at 100mA to allow +12 VDC or +24 VDC regulated +5% worst case.

The 24VDC Output is supplied with a self resetting fuse.

**MEMORY:** EEPROM stores all program and total data for minimum of 10 years if power is lost.

**PULSE INPUT:**

**3A:** (Standard) 4-30VDC 30 k Ohm impedance to GND, 10 kHz max. input speed (min. on/off 50µsec.).

**3C:** (Magnetic Pickup) 30mV to 30V P/P min., 2 Hz to 5 kHz Input Speed.

**ENVIRONMENTAL:**

Temperature:

Operating: +41°F (5°C) to +130°F (+54°C).

Storage: -40°F (-40°C) to +200°F (+93°C).

ET: Extended Temperature -40° to 158°F (-40° to 70° C)

Humidity: 0-90% Noncondensing

Dimensions: See BATCHrol II

**Listing:** CE Compliant, UL/CSA Pending

**FACTORED OUTPUT:** The MASSbatch gives one pulse out for each factored count. The open collector sinks 30 VDC maximum to 1 volt maximum at 100mA maximum. Output speed is user selectable (see table below). An internal buffer holds up to 10,000 pulses for output at the selected frequency before "DATA LOST" flashes, indicating pulses are lost. If factored rate exceeds 7 digits "RFF..." flashes. These alarms indicated that speed has been exceeded.

### Ordering Information

Example: MB8	A	3A	2	H	R3
<b>Series:</b> MASSbatch					
<b>Operating Voltage:</b>	A: 110 VAC ±15% or 15 to 27 VDC B: 220 VAC ±15% or 15 to 27 VDC				
<b>Count Inputs:</b>		3A: (STD) Pulse 4-30 VDC 10 kHz Max. (jumper selectable) 3C: (Mag. Pickup) 30mV 2 Hz to 10 kHz (jumper selectable)			
<b>Control Outputs:</b>		1: Open Collector 2: SPDT Relay 10A			
<b>Input Speed:</b>		L: (Low Speed) 0-40 Hz H: (High Speed) 0-10 kHz			
<b>Options:</b> (Multiple Options Available)		R: RTD and 4-20mA input (jumper selectable) ..... Standard 1: RS232 Serial Interface 2: RS422 Serial Interface 3: 4-20 mA Output (jumper selectable) 3Y: 0-5VDC Output (jumper selectable) 3Z: 0-10VDC Output (jumper selectable) 4: 16 Point Linearization ET: Extended Temperature: -40° to 158°F (-40° to 70° C) CSA: CSA Approved Unit (pending) ..... (consult factory)			

### Accessories:

FLEXCOVER #36120

XTROL7/4- Explosion proof housing, see XTROL 7/4

NEMA 4X wall mount enclosure available, see NEMATROL

Serial printer available, see P1000, P295

Ethernet Port Server available, see IEPS

RS-422/485 to RS-232 Communication Adaptor available, see CA285

# XTROL 7/4

## Explosion Proof Housing for 'trol Products

### Features:

- Compatible with all Standard Size "trol" and "SUPERtrol" Family of Products
- Meets NEMA 7 & 4 Specs.
- For use in Class 1, Division 1, Groups C & D
- For use in Class 2 & 3, Division 1, Groups E, F & G
- FM, CSA Approved
- Specials Available for Custom Conduit Entries



### Specifications:

This housing is designed and manufactured in compliance with FM Standards 3600 & 3615 and CSA Standard C22.2 No. 30-M1986 for use in Class I, Division I, Groups C & D and Class II an III, Division I, Groups E, F & G hazardous locations. It is **certified by:**

**ADALET**

**FM (file# JI 0V2A6.AE)**

**CSA (file # LR36172).**

It is made from cast aluminum and sealed to meet NEMA 7 and 4 specifications. This is accomplished by neoprene gaskets retained in machined grooves in the covers and buttons.

The front button actuators have the same easy-to-use keypad layout that has become the trademark of the KEP "trol" and "SUPERtrol" series. 6 blind threaded holes are provided for mounting with 2 each 1/2" NPT openings for wiring.

To install a unit, the 16 front 3/16" allen screws must be removed and the "trol" mounted in the sub panel provided.

If the assembly option is ordered, only the 8 back cap screws need to be removed to complete the wiring to an optional pluggable connector.

Empty weight is 26 lbs.

### XTROL 7/4\*

**Example:** XTROL7/4 BT2 A

**Series:** XTROL7/4 (housing only)

**Mounting Hardware:** (Includes labels and two piece connector)

BT2 = BATCHtrol II

MB = MASSbatch

FLO = FLOWtrol

KFC = KEPtrol F/C

KP8 = KEPtrol

KRT = KEPtrol R/T

MFC = Mass Flow Computer

DPFC = DPFC

ST1\*\* = SUPERtrol-I

ST1LE\*\* = SUPERtrol-I LE

ST2\*\* = SUPERtrol-II

LT2\*\* = LEVELtrol-II

X = No Mounting Hardware

**CONTROLLERS SOLD SEPARATELY**

**Assembly By KEP:**

A = Assembled by KEP

X = No Assembly

**Note:** When placing the order, the unit part number directly following the XTROL part number on the Purchase Order is the one that will be assembled into the XTROL housing.

\*\* See also XHV series enclosure.

**XTROL 7/4 Dimensions:**

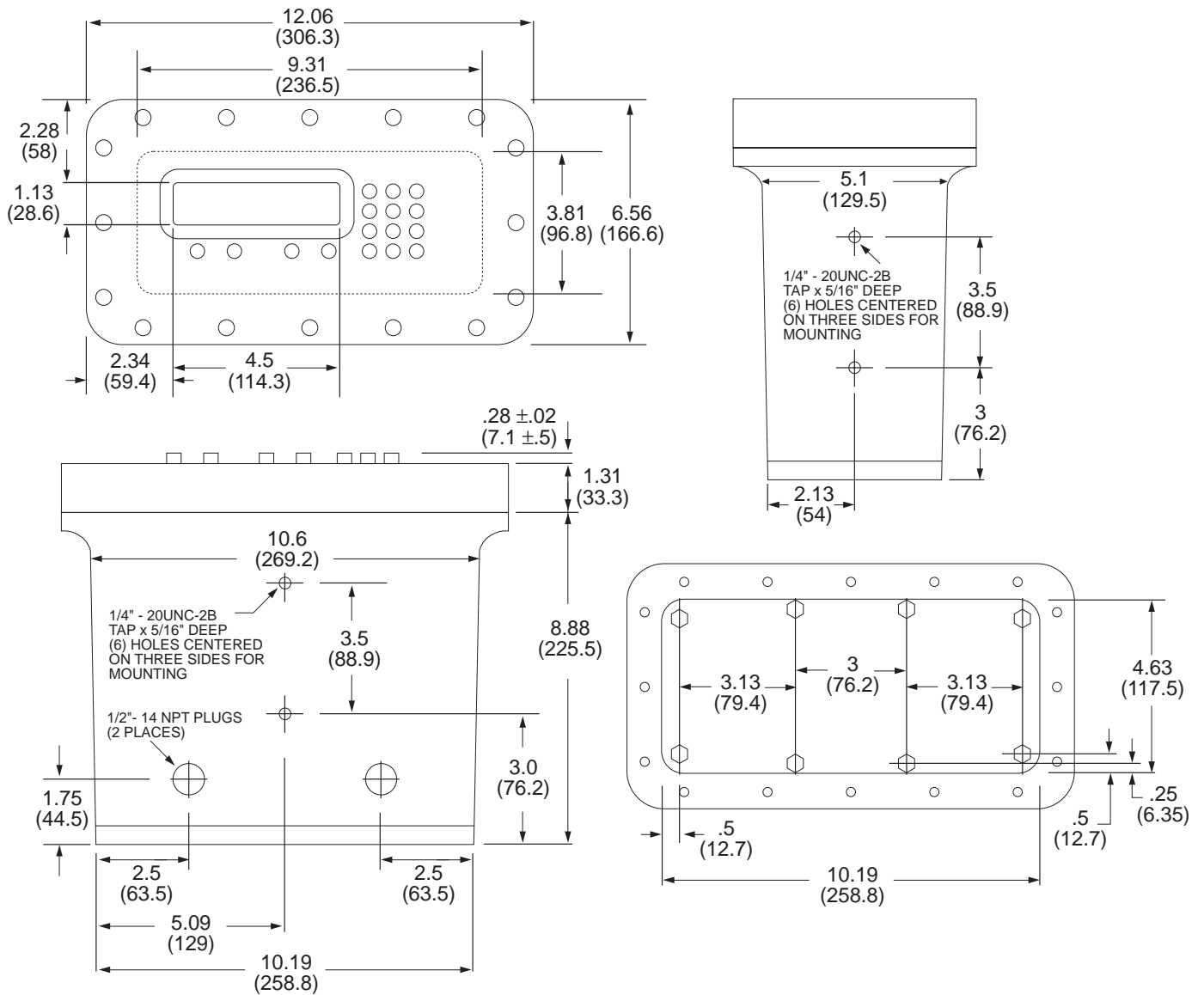

**Assembly:**

If HOUSING ONLY is purchased, all front allen screws and front must be removed. Remove four allen screws so that the 'trol product can be mounted in the internal bracket (gasket not used; top of bracket is the thinner side). Wiring should be done before installing 'trol in the housing unless the MOUNTING HARDWARE with two piece connector is purchased. If the unit is assembled by KEP, only remove the back plate. The pluggable connector can be wired at back.

# XHV Series

*X-Proof Housing for Viewing Displays in Hazardous Areas*

**Features:**

- Available for 1/8 DIN and DIN 144 x 72 mm Cases
- Meets NEMA 7 & 4 Specs.
- For use in Class 1, Division 1, Groups C & D
- For use in Class 2 & 3, Division 1, Groups E, F & G
- UL, cUL Approved
- Magnetic Reset Switch Available

**Specifications:**

This housing is designed and manufactured in compliance with UL Standard No. 1203 and was investigated to CSA Standard C22.2 No. 30-M1986 by UL for use in Class 1, Division 1, Groups C & D and Class II & III, Division I, Groups E, F & G hazardous locations.

**Certified by:**

ADALET  
UL (file# E81696 )

The housing is made from cast aluminum and sealed to meet NEMA 7 and 4 specifications.

To install a unit, the cover must be removed and the KEP unit mounted in the sub panel provided.

**Empty weight:**

XHV = 19 lbs.  
XHVD = 22 lbs.



**Dimensions:**

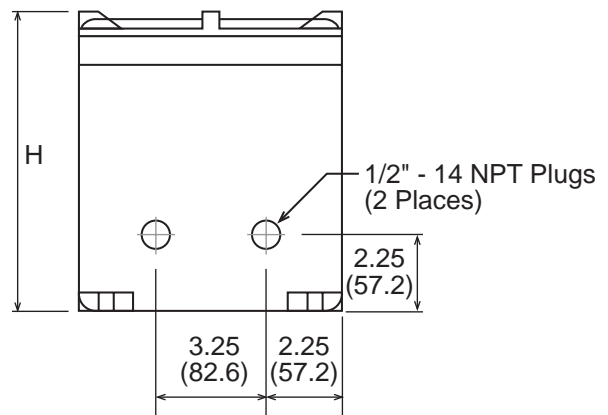
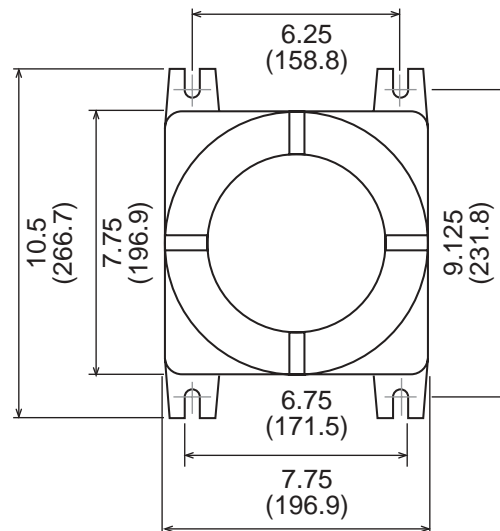

H
XHV = 8.5 (215.9)
XHVD = 11.5 (292.1)

**Ordering Information**

**Example:** XHV 7/4 A A S1  
**Series:** \_\_\_\_\_

XHV 7/4 (8.5" high for INT69, MRT, Reporter, etc.)  
XHVD 7/4 (11.5" high for SUPERtrol 1 and 2, LEVELtrol II)

**Mounting Sub Panel:** \_\_\_\_\_  
A = Panel for (1) 1/8 DIN unit (INT69, MRT, etc.)  
B = Panel for (2) 1/8 DIN units (INT69, MRT, etc.)  
C = Panel for (1) DIN 144 x 72mm unit (ST1, ST2, LT2, Reporter)

**Assembly By KEP:** \_\_\_\_\_  
A = Assembled by KEP  
X = No Assembly

**Options:** \_\_\_\_\_  
S1 = 1 Magnetic Reset Switch and Magnet  
S2 = 2 Magnetic Reset Switches and Magnet

**Accessories:**  
XHVA-1 = Magnetic Switch  
XHVA-2 = Actuating Magnet

**Note:** When placing the order, the unit part number directly following the XHV part number on the Purchase Order is the one that will be assembled into the XHV housing.

Flow Instruments  
ACCESSORIES



# NEMAtrol

## NEMA 4X/IP65 Enclosures For 'trol & 1/8 DIN Cases

### Features

- Compatible with all Standard Size "trol", SUPERtrol & 1/8 DIN Products
- Meets NEMA 4X/IP65 Specs.
- Quick-Release Latches
- Light Weight

### Application:

Ideal for use in most petrochemical plants, sewage plants, food processing areas, packing plants, electroplating plants, etc.

### Construction:

- Molded fiberglass reinforced polyester material has excellent chemical resistance and outstanding physical properties.
- Fiberglass material is easily punched, drilled, filed or sawed.
- Oil-resistant gasket attached with oil-resistant adhesive.
- The enclosures have corrosion-resistant fiberglass hinges and spring-loaded fiberglass latches attached with monel screws.



### Ordering Information

#### Part Number

**NEMAtrol4X** (NEMA 4X enclosure for all standard 'trol units 7.365" x 2.495" cutout)

NEMAtrol 4x0 (no cutout)

NEMAtrol 4x1 (1 cutout)

NEMAtrol 4x2 (2 cutouts)

**NEMAST4X** (NEMA 4X enclosure for SUPERtrol & LEVELtrol II series)

NEMAST 4x1 (1- 5.43" x 2.68" cutout for SUPERtrol series)

NEMAST 4x2 (2- 5.43" x 2.68" cutout for SUPERtrol series)

**NEMA-1/8DIN** (NEMA 4X enclosure for all 1/8 DIN size units)

NEMA-1/8DIN 4x0 (no cutout)

NEMA-1/8DIN 4x1 (1 cutout)

NEMA-1/8DIN 4x2 (2 cutouts)

Physical Properties	Enclosure Value	ASTM Method
Flexural Strength	17,000 PSI	D-790
Heat Distortion	400° F	D-648
Water Absorption (24hrs.)	.5%	D-570
Tensile Strength	6,500 PSI	D-651
Specific Gravity	1.8	D-792
Flammability	94-5V	UL94
Dielectric Strength	400 V.P.M	D-149
Arc Resistance	180 Sec.	D-495

### Dimensions:

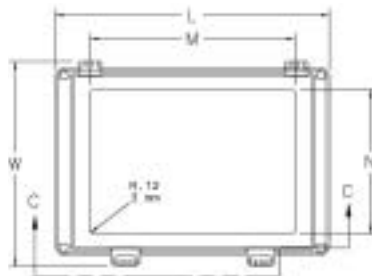

Top View with Cover

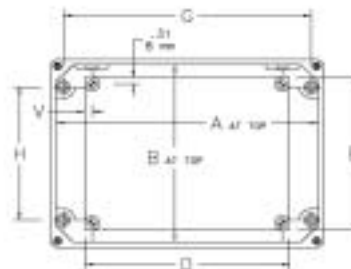

Top View with Cover Removed

NOTES: 1. Panel screws have # 10-32 threads.  
2. Hinged cover opens 30° maximum.

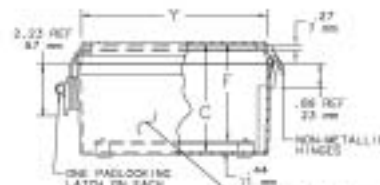
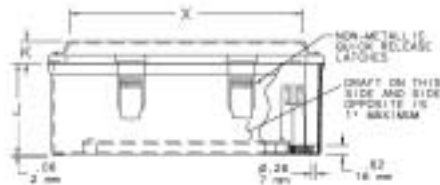

End View

Part Number	A x B x C	D x E	G x H	L x W	F	J	K	V	X	Y
<b>NEMA-1/8DIN</b>	7.50 x 6.00 x 5.28 (191 x 152 x 134)	4.88 x 4.88 (124 x 124)	6.75 x 4.00 (171 x 102)	8.00 x 7.39 (203 x 188)	4.75 (121)	4.38 (111)	1.00 (25)	0.31 (8)	6.22 (158)	5.59 (142)
<b>NEMAtrol4X</b>	11.50 x 8.00 x 6.76 (292 x 203 x 172)	8.75 x 6.88 (222 x 175)	10.75 x 6.00 (273 x 152)	12.00 x 9.39 (305 x 239)	6.25 (159)	5.13 (130)	1.75 (44)	0.25 (6)	9.97 (253)	7.34 (186)

# LCN4X

## Low Cost NEMA 4X Housing for 1/8 and 1/16 DIN Size Units

### FEATURES:

- Made of impact and corrosive resistant VELOX™, RAL 7035
- Molded internal bosses for back panel, component mounting and DIN-rails
- NEMA4X / IP66 Rating
- UL 508 and CSA Type 4, 4X, 3, 3R, 12, 13 Rating
- Temperature resistance: Base and opaque cover to +248°F (120°C) per UL 746B. Polycarbonate cover -40°F (40°C) to +248° (120°C)
- Non-Metallic cover screws
- Continuously poured polyurethane gasket
- Cover and bases meet with tongue and groove design for tight seal



### Dimensions:

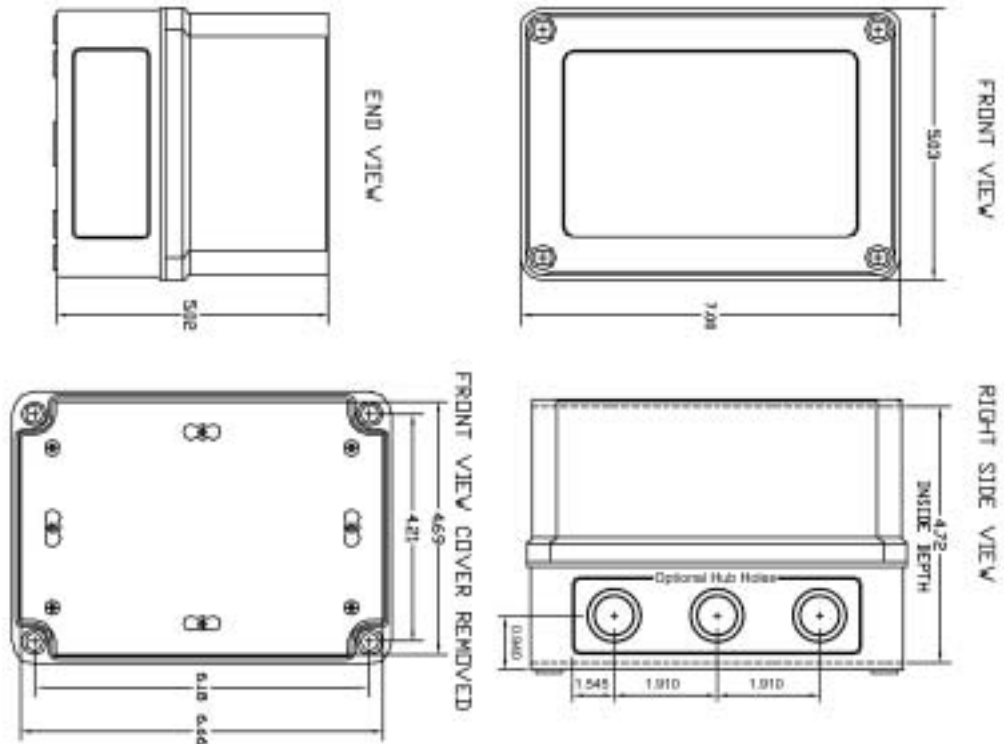

### Ordering Information:

#### Part Number:

- LCN4X 1/8 DIN - for all 1/8th DIN products
- LCN4X 1/16 DIN - for all 1/16th DIN products

#### Options:

- H2 - 0.875" Hole for Hub fitting
- HF2 - 0.5" Female NPT Hub fitting
- 2H2 - Two 0.875" Holes for Hub fittings
- 2HF2 - Two 0.5" Female NPT Hub fittings
- H3 - Three 0.84" Holes for Hub fittings

# E200

Outdoor Enclosures For  
Units in 1/32 DIN Cases

## Features

- Low Cost
- Compatible with all Standard 1/32 DIN Products
- NEMA 3R (raintight) Enclosure
- Quick-Release Latches with Security Lock Provision
- Light Weight

## E200 Plastic Outdoor Enclosure

The E200 is a Plastic NEMA 3R raintight enclosure with hinged door and latch. It offers provisions for mounting up to four of ANY KEP 1/32 DIN sized units. The E200 also offers five combination 1/2"-3/4" knockouts: In bottom, sides and back for easy wiring and conduit connections. Exterior Size: 6.5" x 10" x 3.75" deep. Interior Size: 4.75" x 7.75" x 3" deep. Dark grey plastic finish.



Compatible with all Standard 1/32 DIN Products Including:

- KAL D Series
- KAL D Time Series
- 130K - 136K Series
- 520K - 530K Series

## Dimensions:

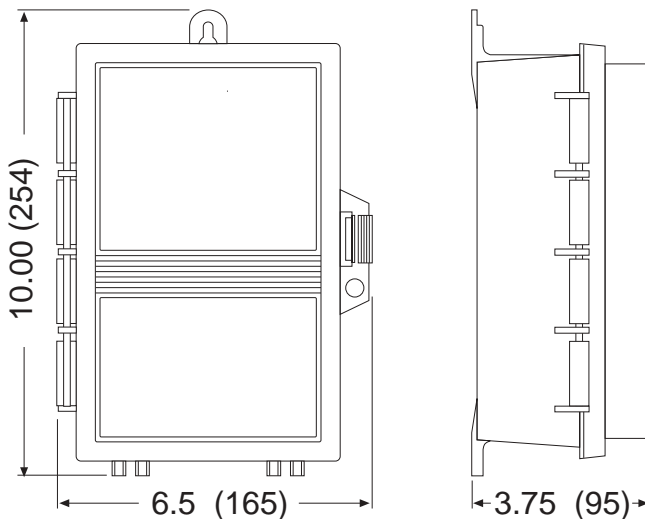

## Ordering Information

Part Number	Description
E200-0	E200 Enclosure with no cutout
E200-1	E200 Enclosure with 1 cutout
E200-2	E200 Enclosure with 2 cutouts
E200-3	E200 Enclosure with 3 cutouts
E200-4	E200 Enclosure with 4 cutouts

# P1000

## Desktop / Handheld Serial Printer

### Features

- Compact Serial Printer (Dot Matrix) for Field Use
- Uses Standard 2.25" Plain Paper Roll
- 24 or 40 Column Printing
- Standard Epson™ Ribbon
- Internal 2KB Buffer
- RS232 With Selectable Baud Rate
- Will Operate for 2 Hours on Internal Batteries for Hand Held Applications

### Applications:

- Logging data from KEP instruments
- Remote messages printing
- Real-time-clock (optional) for time and date stamp
- Plain paper for long lasting record keeping

### Description:

The P1000 printer is a top quality, impact dot matrix micro printer. It is small, light weight, and low in cost, but extremely powerful in performance. This model is portable and designed for applications where regular desktop printers are unnecessary and space is limited. The P1000 is ideal for many uses such as logging data from KEP instruments, direct recording measurements from digital hand tools or electronic scales, remote message printing and more. It is an excellent service aid permitting print outs of setup **information** and helps with troubleshooting problems in the field.

### Dimensions:

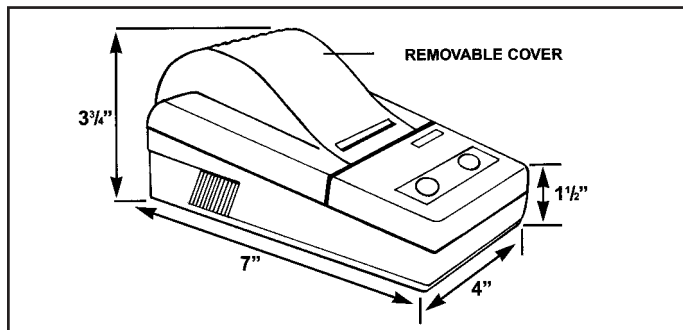

### Ordering Information

<b>EXAMPLE</b>	<b>P1000</b>	<b>1</b>	<b>C</b>
<b>Series</b>	P1000 Printer		
<b>Operating Voltage</b>	1 = 110V AC adaptor 2 = 230V AC adaptor 3 = 12V DC power cord		
<b>Options</b>	C = Real Time Clock (not required for ST1, ST1LE, ST2, LT2)		

### Accessories

- P1AR = Ink Ribbon
- P1AA230 = 230V Adapter (spare)
- P1AA110 = 110V Adapter (spare)
- P1AC25M9MC = 6', Printer cable for ST1 & ST2
- P1AC25M9FC = 6', Printer cable for MRT & INT69
- P1AC25M25MS = 6', Printer cable for all 'trolls
- Other cables available on request



### Specifications:

#### Character Types:

448 defined characters include:  
96 standard ASCII characters  
Math symbols  
Printing symbols  
Block graphic characters  
32 user defined characters

#### Print Method:

Impact Dot Matrix

#### Character:

Standard characters 5x7 dot matrix

#### compositions:

Block graphic char. 6x8 dot matrix  
User definable char. 6x8 dot matrix

#### Dimension:

7" x 4" x 3.25"

#### Baud Rate:

Selectable baud rate & parity setting by key combinations (1200,2400,4800,9600)

#### Print Speed:

40 lines per minute

#### Control Commands:

35 codes, IBM/EPSON

#### Input Buffer:

2k bytes (expandable to 4k)

#### Interface:

RS-232C, 25 pin D-SUB, RS connector

#### Power:

7.5 volt DC input, max. current 750mA with Internal Battery Pack  
110V AC/DC to 7.5V DC adapter supplied.

#### Paper:

Plain adding machine type paper roll, internal mounting up to 130'x2.25" size roll

#### Ink Ribbon:

Porelon ERC 09 or equivalent

#### Options:

220V AC/DC adapter (spare)  
12VDC adapter  
Real Time Clock for time and date stamp at command

# P295

## Miniature Slip Printer

### Features

- Worlds Smallest Slip Printer
- Only 1.6 Kg
- Epson's ESC/POS Command Set
- Easy-To-Use Touch Panel
- Four Print Directions
- Auto Eject
- Compatible with KEP instruments



### Description:

Just 1.6kg and ultra compact, the P295 is the worlds smallest slip printer. Select from among 4 print sizes and four printing directions. Or, use page mode to tell the printer where to print the page. The P295 is also equipped with a host of user-friendly features, such as an easy-to-operate touch panel and an automatic paper eject function.

The P295 offers printing capabilities of normal, double and quadruple size print in either horizontal or vertical formats. The P295 will print multi-part copies, original and two copies and supports dual cash drawer capability. The P295 is uses a serial interface and meets all world-wide regulatory requirements including UL, CSA and CE mark. The P295 utilizes the PA295 Universal Power Supply Adaptor which is an auto-switching supply. The P295 is Windows and OPOS compliant.

### Specifications

<b>Print Method</b>	7-pin, serial impact dot matrix
<b>Print Font</b>	
Font	5 x 7/7 x 7
Column capacity	35 / 42 columns
Character size (mm)	1.6 (W) x 2.9 (H) / 1.3 (W) x 2.9 (H)
Character set	95 Alphanumeric 32 International 128 x 3 Graphic
Characters Per Inch	13.5 CPI / 16.2 CPI
<b>Interface</b>	RS-232C
<b>Data Buffer</b>	512 bytes
<b>Print Speed</b>	2.1 LPS
<b>Paper</b>	
Dimensions (mm)	80(W) x 69(L) x to 182(W) x 257(L)
Thickness (mm)	0.09 to 0.35
<b>Copy Capability</b>	One original and two copies
<b>Inked Ribbon</b>	ERC-27 (Purple)
<b>Power</b>	24 VDC± 10%
<b>Current Consumption</b>	Approx. 600 mA
<b>Overall</b>	180(W) x 19.5(D) x 101.5(H) mm
<b>Dimensions</b>	
<b>Weight</b>	1.6 kg (Approx)
<b>EMI Standard</b>	VCC # 1, FCC class A, CE marking
<b>Safety Standards</b>	UL / C-UL / TUV

### How To Order:

**EXAMPLE      P295**

Series   
P295 Slip Printer

### Accessories

- PA295 = Universal AC Power Supply Adaptor
- PA295DC = Power Supply Adaptor for DC Operation
- P2CA25M9ML6 = 6' Serial Cable for SUPERtrol I, SUPERtrol ILE, LEVELtrol II, SUPERtrol II

# 115 Series

## Cased Power Supply

Features:

- Screw Terminal Connections
- 250 mA of Regulated Power at 5 and 12 VDC
- 115/230 Volt 50/60 Hz Input
- Easily Mounted
- 5, 12 and 24 VDC Models

**Power Supplies:** 115-5, 115-12, 115-24

### Applications:

A compact supply to power various DC operated peripherals and inputs/output modules on PLC's, or transmitters in process control.

### Description:

This module converts 115 VAC to DC. The 115-5 and 115-12 provide 250 mA of regulated DC for all of your 5VDC and 12VDC applications. Model 115-24 is available for all regulated 24VDC at 100mA applications.

**Listing:** CE Compliant

### Sample Hookup to KAL-D R/T

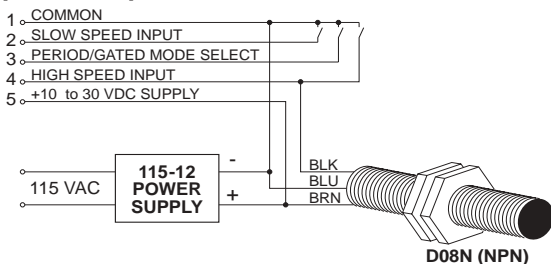

## Ordering Information

### Part Number

- 115-5** 115VAC to 5VDC for all 5 Volt applications
- 115-12** 115VAC to 5VDC for all 12 Volt applications
- 115-24** 115VAC to 5VDC for all 24 volt applications
- 230-24** 230VAC to 5VDC for all 24 volt applications

### Options:

E-Explosion Proof Housing (add E to end of part number)

### Mounting: (115 & AMP-1 Series)

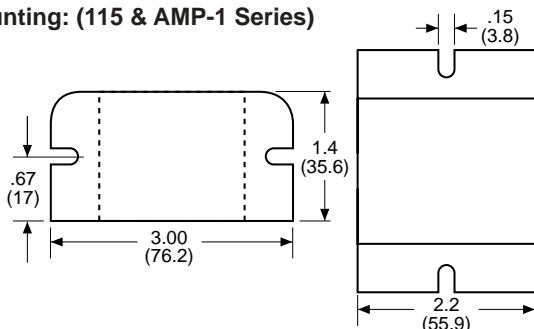

# AMP-1

## Preamp & Signal Conditioner for Magnetic Pickups

Features:

- Ultra Low Speed to 15 kHz Operation.
- 20 mV to 50 V Sensitivity.
- 100 mA Current Sinking Output.
- 11 to 26 VDC Power Supply Range.
- Easy Mount Metal Housing.
- Screw Terminal Hookup.

### Description:

The KEP AMP 1 amplifies the low level signals from a magnetic pickup or flow transmitter by a factor of more than a hundred times to drive any ratemeter, counter or controller. The unit uses only 30 mA and operates from 11 to 26 VDC. It has a 2.7K pullup resistor attached to the open collector output and sinks a minimum of 100 mA to less than 1 V from a maximum of 26 VDC. It is mounted in a rugged 2" x 3" metal housing with screw terminals for easy installation. Operating temperature is 32 to 140° F (0 to 60° C).

**Note:** The low voltage line from the magnetic pickup to the AMP-1 should be less than 10 ft. in length, shielded and isolated from relays, solenoids or other sources of electrical noise (let the output line make the long run). If the input is too sensitive, lower the 1.1K input impedance by adding a 220 to 1K ohm resistor across TB1, pins 1 and 2, to increase noise immunity.

A special version, the AMP1-10k, is available with 10 kΩ impedance for use with turbine and paddle wheel flowmeters.

**Listing:** CE Compliant

### Sample Hookup :

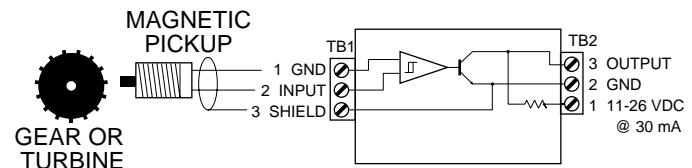

## Ordering Information

### Model

- AMP 1:** Standard unit
- AMP-1-10k:** AMP-1 with 10 kΩ input impedance

### Options:

E-Explosion Proof Housing (add E to end of part number)

# SPARE PARTS

## Spare Parts

ORDER NO.	DESCRIPTION
Model 36120	Flex Cover
KRTBEZEL	Front panel bezel for KEPtrol R/T
BT2BEZEL	Front panel bezel for BT2
KEPTROLBEZEL	Front panel bezel for KEPtrol
MFCBEZEL	Front panel bezel for MASStrol
FLOWBEZEL	Front panel bezel for FLOWtrol
DPFCBEZEL	Front panel bezel for DPFC
MBBEZEL	Front panel bezel for MASSbatch
LVTBEZEL	Front panel bezel for LEVELtrol
KFCBEZEL	Front panel bezel for KEPtrol F/C
ST1LELCDFRONT	LCD Front panel assembly for SUPERtrol ILE
ST1LEVDFRONT	VFD Front panel assembly for SUPERtrol ILE
ST1LCDFRONT	LCD Front panel assembly for SUPERtrol I
ST1VDFRONT	VFD Front panel assembly for SUPERtrol I
ST2LCDFRONT	LCD Front panel assembly for SUPERtrol II
ST2VDFRONT	VFD Front panel assembly for SUPERtrol II
LT2LCDFRONT	LCD Front panel assembly for LEVELtrol II
LT2VDFRONT	VFD Front panel assembly for LEVELtrol II
KP8CASE	Case for KEPtrol
KRTCASE	Case for KEPtrol R/T
BT2CASE	Case for BT2
FIOCASE	Case for Flowtrol
MASSCASE	Case for MASStrol
DPFCCASE	Case for DPFC
ST1LEREAR	Rear Case for SUPERtrol ILE
ST1REAR	Rear Case for SUPERtrol I
ST2REAR	Rear Case for SUPERtrol II
LT2REAR	Rear Case for LEVELtrol II
Model 34503	Mounting Kit for: MRT series, INT69 series, BEACON series
STMOUNT	Mounting Kit for: ST1 series, ST2 series, LT2 series
TROLCLAMP	Mounting Kit (4 clamps & gasket)
*BATCHEMAINRT3L	KP8, KRT, BT2 Mainboard
*FLOWTROLMAIN	FLOWtrol Mainboard
*MASSMAINAC	MASStrol Mainboard, AC Power
*MASSMAINDC	MASStrol Mainboard, DC Power **
*DPFCMAINAC	DPFC Mainboard, AC Powered
*DPFCMAINDC	DPFC Mainboard, DC Powered **
*ST1LEMAINDC2	SUPERtrol ILE Mainboard, DC Powered, 2 Relays
*ST1LEMAINDC4	SUPERtrol ILE Mainboard, ** DC Powered, 4 Relays
*ST1LEMAINAC2	SUPERtrol ILE Mainboard, AC Powered, 2 Relays
*ST1LEMAINAC4	SUPERtrol ILE Mainboard, ** AC Powered, 4 Relays
*ST1MAINDC2	SUPERtrol I Mainboard, ** DC Powered, 2 Relays
*ST1MAINDC4	SUPERtrol I Mainboard, ** DC Powered, 4 Relays
*ST1MAINAC2	SUPERtrol I Mainboard, ** AC Powered, 2 Relays
*ST1MAINAC4	SUPERtrol I Mainboard, ** AC Powered, 4 Relays
*ST2MAINDC2	SUPERtrol II Mainboard, DC Powered, 2 Relays
*ST2MAINDC3	SUPERtrol II Mainboard, DC Powered, 3 Relays
*ST2MAINAC2	SUPERtrol II Mainboard, AC Powered, 2 Relays
*ST2MAINAC3	SUPERtrol II Mainboard, AC Powered, 3 Relays
*LT2MAINDC2	LEVELtrol II Mainboard, ** DC Powered, 2 Relays
*LT2MAINDC4	LEVELtrol II Mainboard, ** DC Powered, 4 Relays
*LT2MAINAC2	LEVELtrol II Mainboard, ** AC Powered, 2 Relays
*LT2MAINAC4	LEVELtrol II Mainboard, ** AC Powered, 4 Relays
KEPTROLDISP	KP8, KRT, BT2, FLO8 Display Board
MASSTROLDISP	MASStrol & DPFC Display Board

\*PROM sold separately (see \_Trol Program Chips at right)  
\*\*Specify voltage when ordering

## MINITROL Input Chips

ORDER NO.	DESCRIPTION
EPLDMRTIN3	High Impedance input chip for Minitrol
EPLDMRTIN5	Up/down control input chip for Minitrol
EPLDMRTIN9	Quadrature input chip for Minitrol

## INT69 & MINITROL ACCESSORIES

ORDER NO.	DESCRIPTION
34235	Non Keyboard Front Panel
34234	Keyboard Front Panel

## BT2 & KRT Retrofit Boards

ORDER NO.	DESCRIPTION
3A/3B	High Imp. 3A & 3 B Pulse Inputs
BA8ANA4-20MA	Input 5A; 4-20 mA Input
BA8ANA0-20MA	Input 5B; 0-20 mA Input
BA8ANA1-5V	Input 5C; 1-5 V Input
BA8ANA0-5V	Input 5D; 0-5 V Input
BA8ANA0-10V	Input 5E; 0-10 V Input
BATCHSQROOT	Input 6A; Square Law Input
*BA8IO7A4-20M	Input 7A; 4-20 mA In 4-20 mA Out
*BA8IO7B0-20M	Input 7B; 0-20 mA In 4-20 mA Out
*BA8IO7C1-5V	Input 7C; 1-5 V In 4-20 mA Out
*BA8IO7D0-5V	Input 7D; 0-5 V In 4-20 mA Out
*BA8IO7E0-10V	Input 7E; 0-10 V In 4-20 mA Out
BA8ANAOUT4-20	4-20mA out for 3A & 3B Inputs
BA8ANAOUT0-20	0-20mA out for 3A & 3B Inputs
BA8ANAOUT0-5	0-5V out for 3A & 3B Inputs
BA8ANAOUT0-10	0-10V out for 3A & 3B Inputs
BATCHRS232	RS 232 Interface Kit
BATCHRS422	RS 422 Interface Kit
MB8IN	MASSbatch Input
*MB8IN/OUT	MASSbatch Input w/ 4-20mA Out

\* For Other Outputs:  
Add suffix X for 0-20 mA (i.e. BA8IO7A4-20MX, MB8IN/OUTX)  
Add suffix Y for 0-5 V out (i.e. BA8IO7A4-20MY, MB8IN/OUTY)  
Add suffix Z for 0-10 V out (i.e. BA8IO7A4-20MZ, MB8IN/OUTZ)

## MASStrol & DPFC Retrofit Boards

ORDER NO.	DESCRIPTION
MASSRS232	RS 232 Interface Kit

## ...TROL Program Chips

ORDER NO.	DESCRIPTION
PROMBT2	PROM for BATCHtrol II
PROMBT216PT	PROM for BT2 w/16Pt
PROMFLO	PROM for FLOWtrol
PROMKFC	PROM for KEPtrol F/C
PROMKP8	PROM for KEPtrol
PROMKRT	PROM for KEPtrol R/T
PROMKRT16PT	PROM for KRT w/16Pt
PROMMFC	PROM for MASStrol(2 chips)
PROMRS	PROM for Trol RS422 & RS232
PROMRS422M	PROM for Trol RS422M
PROMMB	PROM for MASSbatch
PROMMB16PT	PROM for MASSbatch w/ 16Pt
PROMDPFC	PROM for DPFC (2 chips)
PROMLTR	PROM for LEVELtrol
PROMMS627	PROM for MS627 (2 chips)
PROMST1LE	PROM for SUPERtrol-ILE
PROMST1	PROM for SUPERtrol-I
PROMST2	PROM for SUPERtrol-II
PROMLT2	PROM for LEVELtrol-II
PROMST485	PROM for RS-485 option card for SUPERtrol
PROMPEELST2	PEEL PROM for SUPERtrol-II

## NOTES