

DRT (Dual rate/totalizer)

2 Separate Rate/Total Displays with Combination Function

Features

- Displays A,B,&C Rate & A,B,&C Total
- Separate Scaling Factors For A & B Inputs
- "C" Displays A+B, A-B, A÷B, & A÷A+B
- RS422/RS232 Serial Communication
- Modbus RTU RS422/RS485/RS232
- Pulse Input - 10 kHz Max.
- Security Lockout
- NEMA 4X / IP65 Front Panel
- 30mV Magnetic Pickup Inputs

DESCRIPTION:

The DRT (Dual Rate Totalizer) is a dual 5 digit Ratemeter 6 digit Totalizer in a 1/8 DIN package. User selects 1 of 6 displays to show A,B or C rate and A,B or C total. Inputs A and B have separate scaling to read in engineering units.

A 4-20mA (0-20mA) output of the C rate or total is optional.

The user can press the VIEW button to see 6 separate items total A, total B, total C, rate A, rate B, rate C. Negative values are displayed with a negative symbol (- 12345). For the C value, the user can choose from the following combination of A&B inputs: TOTAL; with a choice of A+B or A-B; RATIO with choice of A÷B(x100) to show percent of A to B quantity or A÷[A+B(x100)] to show percent of A to total quantity.

Two independent presets are standard. User selects whether output A is activated by total or rate value of input A or selected C. Output B can be activated by total or rate value of input B or selected C. Outputs activated by A or B total can be set to latch or autorecycle with an adjustable output duration from 00.1 to 99.9 sec. For rate, ratio, or C total outputs pull in when value is equal or above the preset and drop out when value is below the preset minus the selected 0 to 999 hysteresis.

SPECIFICATIONS:

DISPLAY:

6 digit, 0.55" High LED

INPUT POWER:

110 VAC ± 15% or 12 to 15 VDC

220 VAC ± 15% or 12 to 15 VDC

24VAC ± 15% or 12 to 15 VDC

CURRENT:

250 mA DC max. or 6.5 VA AC

OUTPUT POWER: (AC powered units only)

+12 VDC @ 50 mA, unregulated -10 + 50%

TEMPERATURE:

Operating:

+32°F (0°C) to +130 F (+54°C)

Storage:

-40 F (-40°C) to +200°F (93°C)

HUMIDITY:

0-90% Noncondensing

MEMORY:

EEPROM stores data for 10 years if power is lost.



- 4-20mA or 0-20mA Analog Output
- CSA Approved

INPUTS:

3: High Impedance DC pulse input 4-30 VDC (high), Open or 0-1 VDC (low), 10 KΩ imp. 10 kHz max. speed. Accepts simultaneous inputs. May be used with KEP 711 series or PD & D series sensors.

3M: Mag. Input, Input A only, accepts 30mV input (50 V max. P/P) signals 10 KΩ imp. 5 kHz max. (Input B, 4-30V)

3MB: Mag. Input, Inputs A & B, accepts 30mV input (50 V max. P/P) signals 10 KΩ imp. 5 kHz max.

RESET:

Front Panel: Resets displayed value and control output

Remote: 4-30 VDC negative edge resets all counters, "A" counter or "B" counter (user selectable).

K FACTOR/SCALING

The DRT has two separate K-Factors that are used to convert the input pulses to engineering units. The 5 digit K-Factor dividers, with decimal keyed into any position, allow easy direct entry of any K-Factor from 0.0001 to 99999. Separate factors may be entered for the 2 separate input channels.

CONTROL OUTPUTS:

Relays:

2 each N.O. Relay; 10 Amps 120/240 VAC or 28 VDC. (N.C. relay contacts and NPN transistor output available with solder jumpers. Transistor output is internally pulled up to 10 VDC through relay coil, sinks from 10 VDC to .5 V @ 100 mA)

Analog Output:

An optional 4-20mA (0-20mA) output is available for the DRT. The output can be programmed to track rate or total of the C display. This feature is available by adding suffix A to the part number. Connections are via a 2 terminal pluggable screw connector.

Programming is accomplished by using the front panel in conjunction with rear dip switches.

Accuracy: 50uA worst case.

Compliance Voltage: 3 to 30 VDC non inductive.

Approvals: CSA File# LR91109-7, CE Approved

PRESETS

Two control outputs are provided. To set relay values, press "menu" button until "Relay" appears on the display, the A and B outputs can be assigned to the A, B or C displays. A 5 digit value can be entered for both presets and the decimal point location is the same as the counter. The outputs can be set to energize from 0.1 to 99.9 seconds or latch (0.0). If a value other than 0.0 is entered, the counters will auto reset at the preset (for A&B counters).

LOCKOUT

Unauthorized front panel changes can be prevented by entering a user selected 5 digit code. The front panel can be completely locked out or the presets can remain accessible.

RATEMETER

Accurate to 4 1/2 digits (± 1 display digit). The ratemeter uses 1/tau with 8 digit math, can sample from 2 to 24 seconds maximum, and auto-range up to 5 digits of significant information. In the "RPS" mode, the ratemeter displays in units per second, and in the "scale" mode, units per hour or per minute. The unit will display the rate of the A&B Inputs.

COUNTER

The two 5-digit counters can count at 10Khz speed. Each has a separate 5-digit dividing scale factor. The counters advance on the positive edge of each pulse. Besides being able to step through the total and rate values of A & B inputs, the user can

see a selected combination of total and rate of A+B, A-B, A÷BX100 (percent of A to B), A÷A+BX100 (percent of A to total). The unit can be programmed to view the Total/Rate value of "A+B" & "A-B", or "A÷B" & "A÷A+B".

RS232/RS422 with KEP Protocol:

If the serial interface option is supplied, up to 99 units can be linked together. (The terminal addressing the unit must be capable of driving all loads in the loop.) Unit status and new set points can be communicated by serial communication. Mode changes, however, must always be made on the front panel. Data is received and transmitted over standard EIA RS232 or RS422 levels. Unit number, baud rate and parity are entered in the "Program Setting" set up mode and remain in memory even if power is off.

RS232/RS422/RS485 with Modbus RTU Protocol:

The serial port can be used for serial printing or also for data acquisition. The unit can address up to 247 units (The terminal addressing the unit must be capable of driving all loads in the loop.) The unit can communicate with a master device through a Modbus-RTU protocol. The data given for each parameter is in IEEE float format comprising of 2 words. The unit can be connected in a network.

- Device ID: 01-247
- Baud Rates: 300, 600, 1200, 2400, 4800, 9600
- Parity: None, Odd, Even
- Protocol: Modbus RTU (Half Duplex)

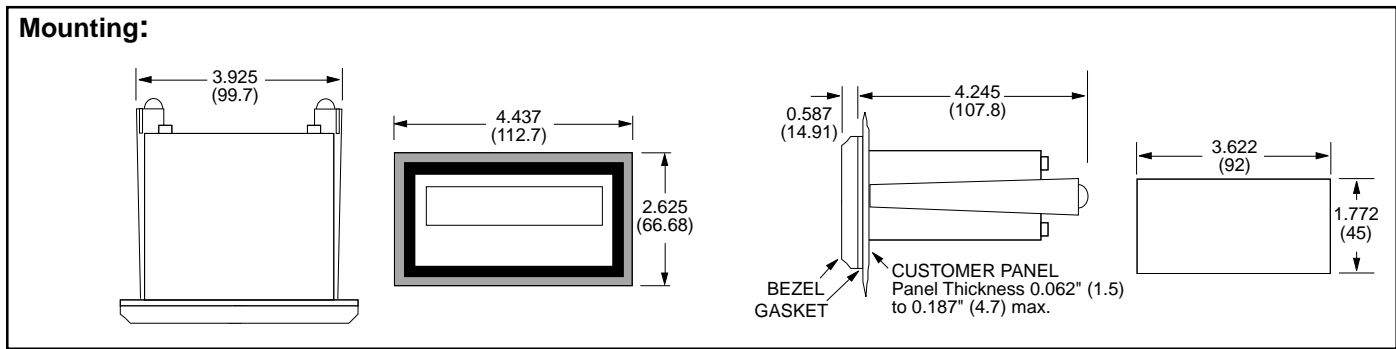

Terminals:

- 1- COMMON
 - 2- N.O.(N.C./NPN)
 - 3- COMMON
 - 4- N.O.(N.C./NPN)
 - 5- A INPUT
 - 6- B INPUT
 - 7- 12VDC OUT/+DC IN
 - 8- -DC (GROUND)
 - 9- RESET INPUT
 - 10- NOT USED
 - 11- A.C. INPUT
 - 12- A.C. INPUT
 - 13- V+
 - 14- I SINK
- RELAYS A B
ANALOG OUTPUT
- | | | |
|---|--------|--------|
| | OFF | ON |
| 4 | RUN | CAL. |
| 3 | 4-20mA | 0-20mA |
| 2 | RATE | COUNT |
| 1 | RUN | SET |
- SWITCH ON

Ordering Information

Example: DRT A 3 1

Series: DRT = 6 digits, counter / ratemeter with presets and scaling.

Operating Voltage: A = 110 VAC $\pm 15\%$ or 12 to 15 VDC
B = 220 VAC $\pm 15\%$ or 12 to 15 VDC
C = 24 VAC $\pm 15\%$ or 12 to 15 VDC

Count Inputs: 3 = Standard, 4-30 VDC simultaneous inputs.
3M = Mag. Input, Input A only, 30mV input (Input B, 4-30V)
3MB = Mag. Input, Inputs A & B, 30mV input

Options: (Multiple Options Not Available)
A = Analog Output (4-20/0-20 mA)
1 = RS232 Communications
2 = RS422 Communications
3 = Modbus RTU RS232
4 = Modbus RTU RS422/RS485

Accessories:
Separate non keyboard panel order #34235
Separate keyboard panel - order #34234