

Product Catalog

Industrial Instruments



KEP

CERTIFIED
ISO 9001



Quality Policy

It is Kessler-Ellis Products quality policy to provide our customers with products and services that comply with requirements while meeting or exceeding their needs and expectations for performance, reliability and safety at a competitive cost. In support of this policy, we are committed to continually improving the effectiveness of our quality management system and to ensure an adequate framework for the establishment and review of quality objectives. We also strive to:

- Treat our employees with respect.
- Do everything possible to satisfy our customers.
- Be a great company to work for in our community.

Through a long-term commitment to this policy, we will be known as a company that cares about our customers, vendors, and employees, while offering the highest quality products at fair prices.

This policy has been formulated by the President of KEP, and is considered appropriate and consistent with KEP's overall business policies. It is reviewed on an on-going basis to ensure its continuing suitability.

KEP ensures that the policy is communicated and understood at all levels in the organization. This is done by posting it in conspicuous locations throughout the company and through training given to existing and new employees.

PETER SABAT
PRESIDENT, KEP

KEP

Industrial Instruments

INDEX

New Products **PAGE 3** **See what's new at KEP.**

<u>COUNTERS</u>	<u>PAGE</u>	<u>DESCRIPTION</u>
KE610/710	4	Super low cost 6 digit counter for gaming, vending and general totalizing applications
E660 / E760	6	Small, 6 or 7 digit counter with panel or base mounting. Ideal for gaming and vending machine applications
K0 Series	8	Small, PC board mount, panel mount or base mount, very low cost, 4-7 digit counter
W15	10	Our lowest power consumption 5 digit counter with reset capability
B Series	12	Standard 25x50mm dia. cutout, high speed, 6-8 digit counter
MK 16-18 Series	14	Highest performance electromechanical counter, 6-8 digits
KAL-DIN	16	Self-powered totalizing (lithium battery), 8 digits, LCD
KAL-DIN AS	18	Self-powered add-subtract, 8 digits, LCD
130K - 133K	19	Battery Powered Counters with LCD Display
MICRO-KAL	21	Miniature, self-powered counter, low cost, 4 digits, LCD
MINI-KAL	22	PC board mount, low cost, LCD
SLIM-KAL	24	Easy mount, large digits, LCD
XL-10	25	Self-powered, rugged case, LCD
K SERIES	27	DC powered, 25x50mm cut-out, battery backed, LED
MC SERIES	29	10 kHz totalizer, 1/8" din cutout, LED
CTR-544	31	LED, Counter, Timer or Ratemeter
SKAL (Super-Kal)	33	Miniature Ratemeter and Totalizer with Scaling
520K Series (520K-530K)	35	Pulse Counters, Position Displays, Rate Meters, Time Meters & Combination Units

<u>PRESET COUNTERS</u>	<u>PAGE</u>	<u>DESCRIPTION</u>
BVA	37	Electromechanical preset counter, 5 digits
CTF5	39	5 Digit, Preset Counter/Timer/Frequency meter with scaling, LED
CTF16/17	41	6 Digit, Preset Counter/Timer/Frequency meter with scaling, LED
KP8 (Keptrol)	43	High speed versatile counter, LED
PM2 (Positrol)	46	Dual input, scalable position monitor, LED
ST (SHIFT-trol)	48	Pulse input, scalable shift monitor, LED
KATSP (KALtrol-SP)	50	Self powered preset counter, replaces electro-mech. units, LCD
903K & 904K	52	Preset Counter/Timer/Frequency Meter, 2-line LCD

<u>COUNTERS/RATEMETERS</u>	<u>PAGE</u>	<u>DESCRIPTION</u>
TR-545	54	LED, Totalizer and Ratemeter
MINITROL (MRT)	56	Preset Counter/Ratemeter with scaling, 2 pulse inputs, 2 relay outputs and LED display
DRT	59	Two Separate Ratemeters/Totalizers with Combination Function, 2 pulse inputs, 2 relay outputs and LED display
RTP	61	Two Separate Ratemeters/Totalizers with Two Line LCD Display
INTELLECT-69 (INT69)	63	Preset Counter/Ratemeter with scaling, analog input, 2 relay outputs and LED display
PMT-555	65	Process Monitor and Totalizer with analog input, 2 relay outputs and LED display

<u>TIMERS</u>	<u>PAGE</u>	<u>DESCRIPTION</u>
HK17 Series	67	7 digits, hours and 1/100ths, low cost, fits into Hobbs cutout, AC or DC
HK07 Series	69	7 digits, hours, tenths and 1/100ths, shock resistant, PCB or panel mount, low cost, DC voltages
H57	71	7 digits, hours and 1/100ths, AC or DC
HC77	72	7 digits, combination hour meter & totalizer
HC67	73	7 digits, combination hour meter & totalizer
M Series	74	Multi-resolution, AC or DC
HB26 Series	75	AC or DC, 6 digit Hour Meter with reset
H37 Series	77	AC or DC, shallow depth, 7 digit, replaces HB17
KAL-DIN TIME	78	Self-powered, AC or DC input, multi-resolution, 8 digit LCD
134K - 135K	80	Self-powered, multi-resolution timer with LCD display
XL-10	82	Self-powered, multi-resolution
523K, 524K, 527K, 528K	35	Time Meters (See 520K Series)
CTR-544	31	LED, Counter, Timer or Ratemeter

KEP

Industrial Instruments

INDEX

(continued)

<u>PRESET TIMERS</u>	<u>PAGE</u>	<u>DESCRIPTION</u>
HVA	84	Electro-mechanical, single preset, AC or DC timer.
DT20	86	24/12 hour (AM/PM) day timer with 20 programmable presets
TR910	88	Programmable Time Relay with LCD Display
INT62A	90	Single preset, LED display
<u>DIGITAL PANEL METERS</u>	<u>PAGE</u>	<u>DESCRIPTION</u>
529K/530K	35	Analog Input DPM (See 520K Series)
531	92	Miniature Temperature Monitor for Pt100 and Ni100 RTD's
532	93	Miniature Temperature Monitor for J, K & N Thermocouples
TP554 Series	94	Temperature/Process Monitor with or without Alarms
BEACON Series	95	Low cost, 3 ^{1/2} digit, LED, current or voltage panel meters
<u>INPUT MODULES</u>	<u>PAGE</u>	<u>DESCRIPTION</u>
HVM	97	High Voltage Module allows products with low DC (3-30V) inputs to accept 5-240 VAC/DC input signals.
<u>RATE INDICATORS</u>	<u>PAGE</u>	<u>DESCRIPTION</u>
KAL-DR/T	98	Small ratemeter/totalizer with LCD display
136K	100	Battery powered ratemeter/totalizer with LCD display
PROTROL (PRA)	101	Rate indicator with 2 Rates, net rate, ratio, or draw
MINITROL (MR)	56	Rate indicator with LED display
MINITROL (MR2)	56	Scalable rate indicator with 2 relay outputs and LED display
DRT	59	Two Separate Ratemeters/Totalizers with Combination Function, 2 pulse inputs, 2 relay outputs and LED display
INTELLECT 69 (INT69R)	63	Rate indicator with analog input, 2 relay outputs and LED display
PMT-555	65	Process Monitor and Totalizer with analog input, 2 relay outputs and LED display
522K, 524K, 525K	35	Rate meters (See 520K Series)
<u>ENCODERS</u>	<u>PAGE</u>	<u>DESCRIPTION</u>
5800 Series	103	Precision, small, round incremental shaft encoder
9000 Series	105	Precision, shock resistant, round incremental shaft encoder
200 Series	107	Hollow shaft incremental encoder
700 Series	109	Cubed incremental shaft encoder, many styles available
Encoder Accessories	112	Measuring Wheels and Encoder Mounting Brackets
<u>SENSORS</u>	<u>PAGE</u>	<u>DESCRIPTION</u>
Magnetic Switches	113	Magnet actuated switches available in many different styles
D Series Sensors	116	Inductive proximity sensors, NPN or PNP outputs
PD Series Sensors	118	Photo-Electric Sensors, many styles available
<u>ACCESSORIES & REPLACEMENT PRODUCTS</u>		
Replacement Products	122	
Spare Parts/Accessories	123	
N7 Housing	124	Explosion Proof Housing for Various Counters & Timers
N12 Housing	125	NEMA 12 Housing for Various Counters & Timers
E200 Housing	126	Plastic Outdoor Housing for 1/32 DIN Size Units
NEMAtrol	127	NEMA 4 Enclosures for Various Counters & Timers
<u>Installation Considerations</u>	128	Installation Of Electronic Instruments In Industrial Environments

New Products

130K Series



Miniature Counters, Timers & Ratemeters

130K/131K/132K/133K - Totalizers

134K/135K/ - Time Meters

136K - Ratemeter/Tachometer

Standard 1/32 DIN Case

See Pages 19, 80, 100 for Details

531 and 532



Temperature Displays

531 - Temp. Display for Pt100 and Ni100 RTD's

532 - Temp. Display for J, K & N Thermocouples

Standard 1/32 DIN Case

See Pages 92, 93 for Details

CTR-544 & TR-545



Counter, Timer, Ratemeter

CTR544 - Counter, Timer or Ratemeter

TR545 - Totalizer and Ratemeter

Standard 1/8 DIN Case

See Pages 31, 54 for Details

PMT-555



Process Monitor and Totalizer from Analog Inputs

Standard 1/8 DIN Case

See Page 65 for Details

TR-910



Programmable Time Relay with LCD Display

Standard 1/16 DIN Case

See Page 88 for Details

KE 610

6 Digit Counter, Non Reset

Features

- Low Cost, Large Quantity Discounts
- Patented High Performance Mechanism
- UL & CSA Approved (KE610)
- Rugged Plastic Package
- Many Voltage Ranges Available
- Long Life



Applications:

The compact design and various mounting styles of the KE610 make it the ideal counter for almost all counting applications. This electro-mechanical counter will not lose its count during power failures or from electrical noise. The KE610 is used in:

- MAIL EQUIPMENT
- PHOTO MACHINES
- VENDING MACHINES
- GAMING MACHINES
- ELEVATORS
- COPY MACHINES
- TICKET MACHINES

Description:

The KE610 Series incorporates the latest manufacturing technology together with a patented basic design to achieve high performance over a wide temperature range with low power consumption. These counters can be mounted by 2 front flange styles, base flange, behind the panel (front mount), or rear screws. The KE610 has UL/CSA approvals and can operate over a wide voltage range of DC or AC power.

Specifications:

Digits: 6 or 7

Digit Size: 0.160" white on black. Colors available.
Special 0-5-0-5 available.

Operating Voltage $\pm 10\%$:

DC: 4.5, 6, 12, 24, 48, 115 (2W)

AC: 24, 48, 120, 230 (5VA)

Reset: None

Count Speed: 10 CPS, standard. 50/50 ratio on/off.

Max. On Time: Infinite

Temperature: Storage: 14°F to 122°F (-10°C to +50°C).

Operating: 23°F to 104°F (-5°C to +40°C).

Approvals: UL# E60420, CSA# LR 91109-4

Termination: UL/CSA wire leads, 10" long, standard.

Specials: Many specials available. Consult factory.

Weight: 4 oz. (113 g.)

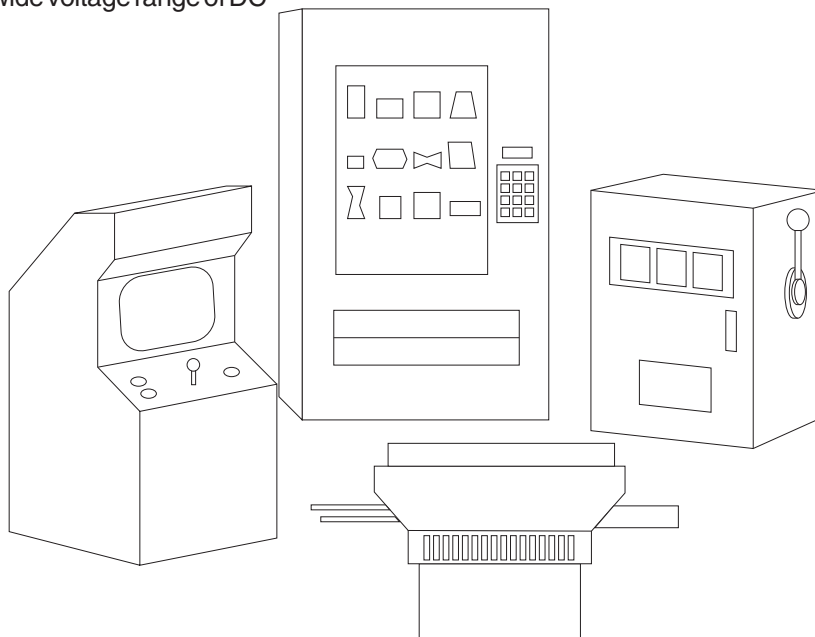

FL & F3 Flange Mount

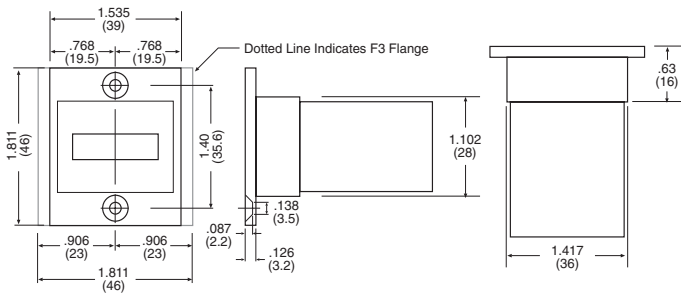

R Rear Mount

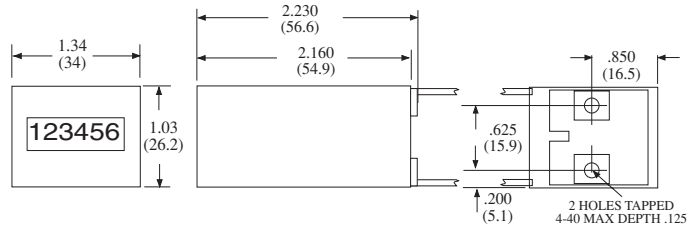

F Front Mount

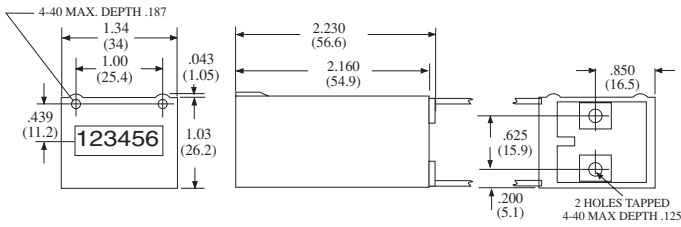

B Base Mount

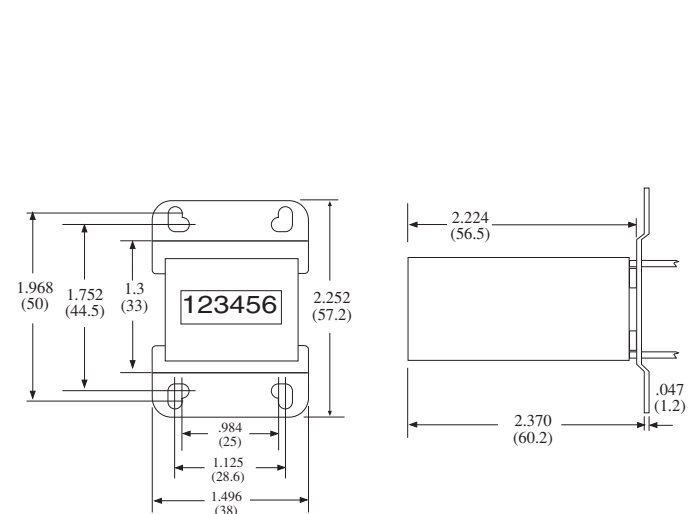

FB Front & Base Mount

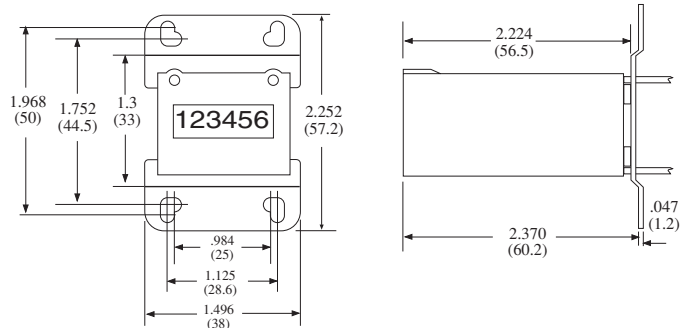

How To Order

EXAMPLE: KE 610 A FB 10 DC 12

Series KE610 = 6 Digit

Special Features A
 (Omit if no special feature desired)
 A = Add Diode Suppression (DC only)
 .01 = Coin, 2 wheels red on black
 .05 = Coin, 2 wheels red on black (steps 05, 10, 15 ...)

Mounting FB
 FL = Flange Mount 1.535" x 1.811"
 F3 = Flange Mount 1.811" x 1.811"
 F = Front
 FB = Front & Base
 R = Rear Mount
 B = Base Mount

Count Speed 10
 10 = 10 CPS (Standard)

Operating Voltage DC
 AC
 DC

Voltage Level 12
 DC: 4.5, 6, 12, 24, 48, 110
 AC: 24, 48, 120, 240

E660, E760

6 or 7 Digit Counter, Non Reset

Features

- Low Cost, Large Quantity Discounts
- Rugged ABS Case
- Many Voltage Ranges Available
- Long Life
- Compact Size

Description:

The E series incorporates the latest manufacturing technology together with a basic design to achieve high performance over a wide temperature range with very low power consumption. These counters can be mounted by snap-in front flange or rear screw mount.

Applications:

The compact design and competitive pricing of the E660 and E760 make them the ideal counters for almost all counting applications. These electro-mechanical counters will not lose their count during power failures, or from electrical noise. The E660 and E760 are used in:

- Mail equipment
- Photo machines
- Vending machines
- Gaming machines
- Elevators
- Copiers and printers
- Ticket machines
- Laundry machines

Specifications:

Operating Voltage: (+/-10%)

DC: 5,12,24 (1.2W)

Display: Six or seven digit, .110" (2.8mm) high. White on black.

Count speed: 10 CPS standard. 15 CPS optional. 50/50 ratio on/off.

Max. On time: Infinite.

Reset: None.

Termination: UL/CSA wire leads, 13.78" (350mm).

Operating temperature: 23° F to 104°F (-5°C to +40°C).

Storage temperature: 14°F to 122°F (-10°C to +50°C).

Weight: 1 oz. (28.35 grams).

Specials: Many specials available. Consult factory.

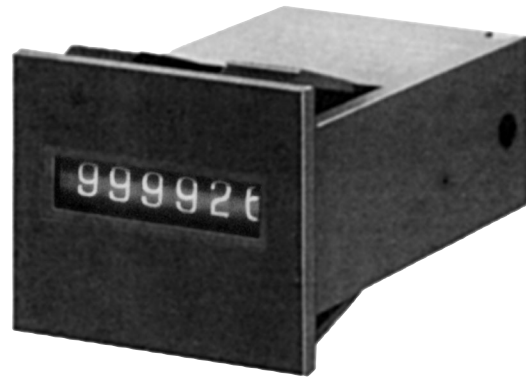

How To Order:

EXAMPLE:	E660	A	P	10	DC	12
Series	E660 = 6 Digit Counter E760 = 7 Digit Counter					
Special Order Features	_ = Blank if standard A = Diode across Coil M = M3 Threads					
Mounting	P = Panel Mount R = Rear Mount (4-40) F = Front Mount (4-40) FI = Front Mount (4-40) with inserts RT = Rear Mount (4-40) with Terminal Pins for PCB Mount B = Base Mount					
Count Speed	10 = 10 CPS (standard) 15 = 15 CPS (optional)					
Operating Voltage	DC					
Voltage Level	DC: 5, 12, 24					

Dimensions

Panel Mount

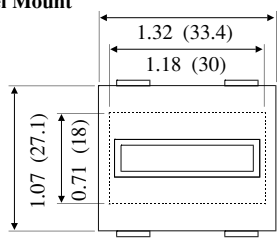

Panel Thickness	A
0.04~0.06 (1.0~1.4)	0.95~0.97 (24.2~24.6)
0.06~0.08 (1.4~2.0)	0.97~0.98 (24.3~24.7)

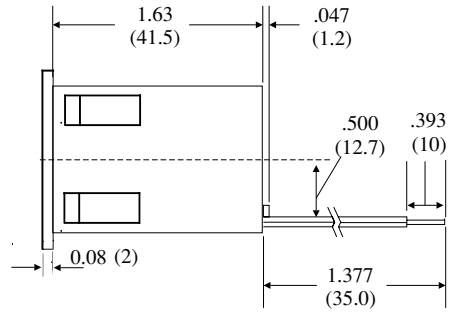
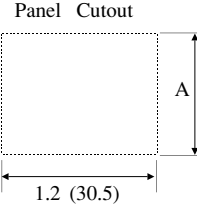

Rear Mount

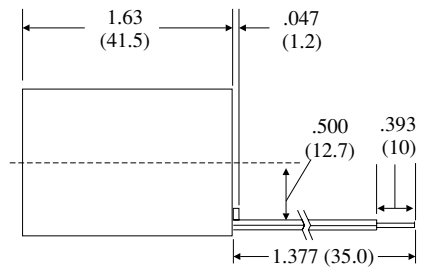
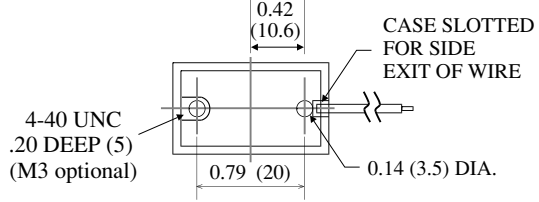
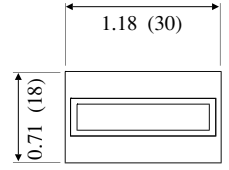

Front Mount

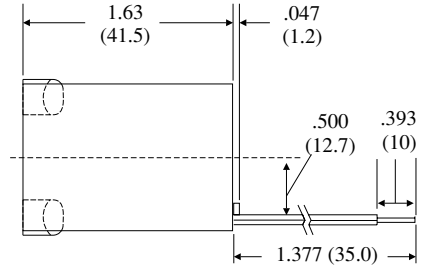
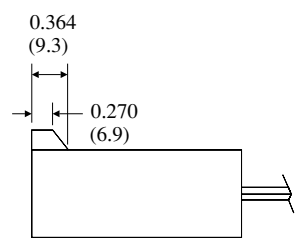
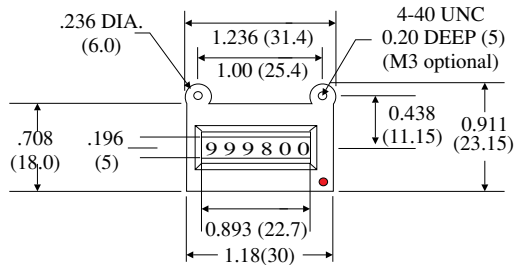

Base Mount

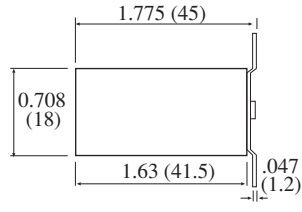
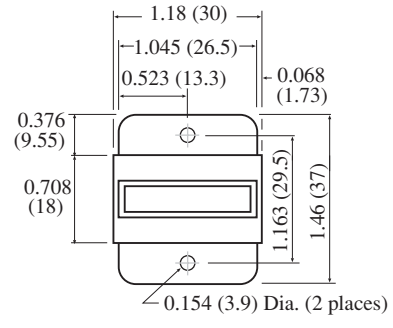

Pin Terminal Type

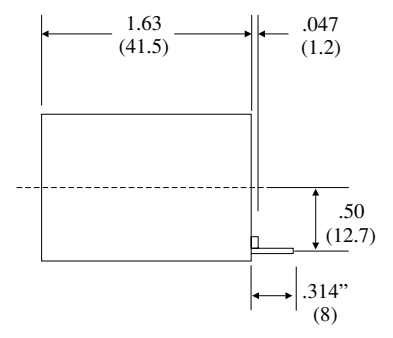
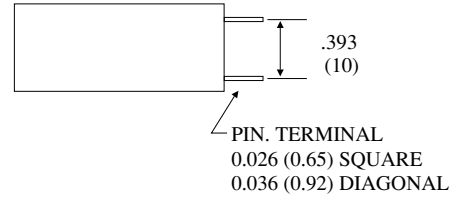
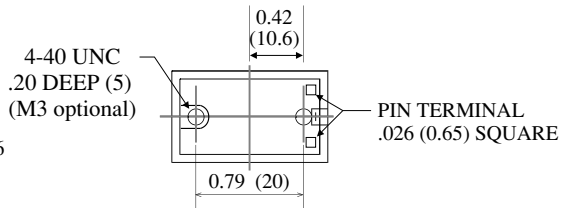
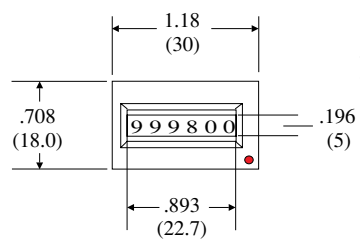

K0 Series

Features

- UL Approved, CE Certified
- Super Small
- Low Power Consumption
- 4, 5 or 7 Digits
- 3 Mounting Styles
- Extended Temperature Option (-30° C to +85° C)
- Long Life

Applications:

- Dispensing Equipment
- Medical Equipment
- Copy Machines
- Gaming Machines

Description:

The K0 Series is a tiny 4, 5 or 7 digit totalizer. The armature system and novel anti-shock and vibration driving system provide a high degree of counting accuracy at a very low power consumption (250mW STD.; 30mW OPT.). Wear resistant materials provide a long maintenance free life, even at extreme temperatures. Versions supplied with a metal case provide electro-magnetic tamper-proof.

Specifications:

Digits: 4, 5 or 7 - 0.158" high, white on black.

Weight: 0.60 oz. (17g)

Reset: None

Terminations: Wire leads or PC board mount with silver-plated pins or optional .02" x .11" tabs.

Approvals: UL# E43429, CE Approved

Temperature: +14°F to +140°F (-10°C to +60°C)

Count Speed:

STD: DC 25CPS; (250mW)
MIN. on/off 20mSec

OPT: DC 10CPS; (30mW)
MIN. on/off 50mSec

NOTE: Power of 30mW must be maintained even on increase of temperature.

AC: 10CPS (.8VA);
MIN. on/off 50mSec

Electro-Mechanical Totalizers

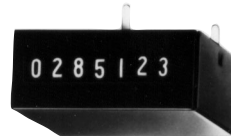

How To Order:

EXAMPLE: K0 7 .20 .35 12VDC

Series	Digits	Style	Options	Voltage
K0 (basic series) AK0 (base mount)	4 = 4 digits 5 = 5 digits 7 = 7 digits	.00 (AK0 only) = plastic case, display on narrow side, wire leads, base mount, magnifying lens .20 = plastic case, display on narrow side, wire leads, flush mount (snap in), magnifying lens .40 = sheet steel case, display on broad side, solder pins, PCB mount, magnifying lens .50 = sheet steel case, display on narrow side, solder pins, PCB mount, magnifying lens .60 = sheet steel case, display on broad side, solder pins, PCB mount, flat lens .70 = sheet steel case, display on narrow side, solder pins, PCB mount, flat lens .80 = plastic case, display on narrow side, solder pins, PCB mount, magnifying lens .90 = plastic case, display on broad side, solder pins, PCB mount (wash proof), magnifying lens .92 = plastic case, display on narrow side, solder pins, PCB mount (wash proof), magnifying lens	.35 = flat pins with .02" x .11" push on connectors (.20 Mount Style Only)	3, 5, 12, 24 VDC ± 10% 24, 110, 220 VAC ± 10% (Other voltages available, Consult factory)

Special Options (add to end of part number)

- 0 = Low power DC versions (30mW), 10CPS
- ET= Extended Temperature -30°C to +85°C

Dimensional Diagrams:

**K04.20/DC,AC
K05.20/DC,AC
K07.20/DC,AC**

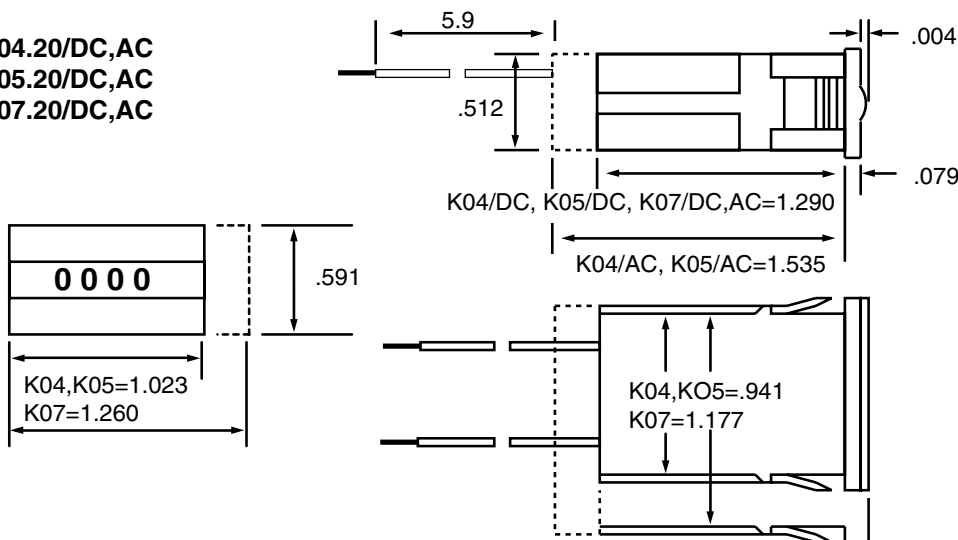

Panel cut out

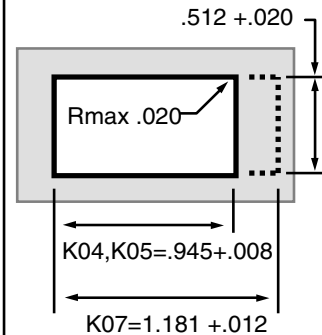

**MAG. LENS
K04.40/DC
K05.40/DC
K07.40/DC,AC**

**FLAT LENS
K04.60/DC
K05.60/DC
K07.60/DC,AC**

**MAG. LENS
K04.50/DC
K05.50/DC
K07.50/DC,AC**

**FLAT LENS
K04.70/DC
K05.70/DC
K07.70/DC,AC**

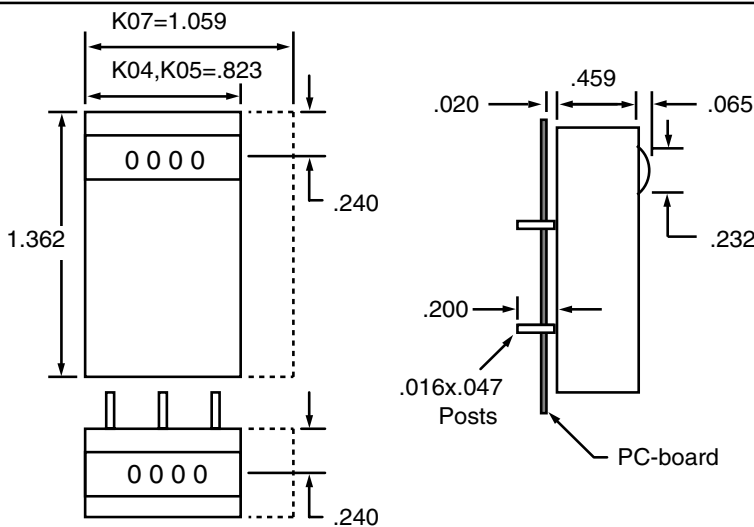

Punching diagram for PCB
(component side)

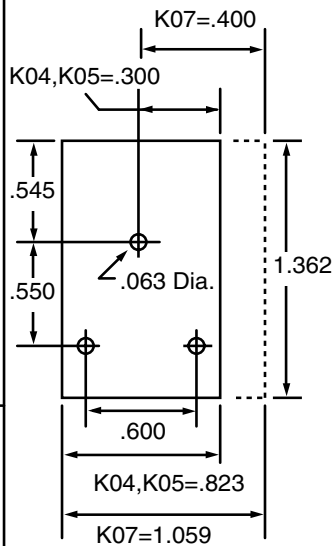

**AK04.00/DC
AK05.00/DC
AK07.00/DC,AC**

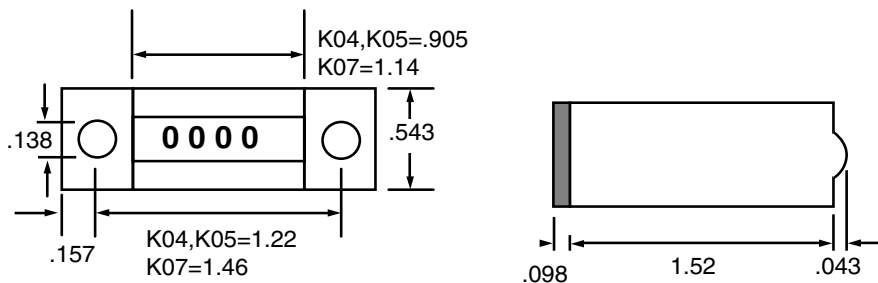

**K04.80/DC
K05.80/DC
K07.80/DC,AC**

**(K04.92/DC)
(K05.92/DC)
(K07.92/DC,AC)**

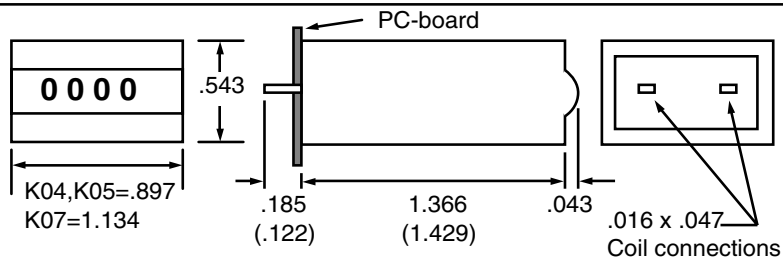

Punching diagram for PCB
(component side)

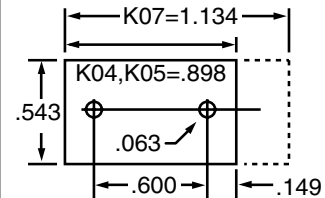

W15 Series

Low Cost, Reset Totalizer

Features

- Super Low Power
- 5 Digits
- 3 Mounting Styles
- 2 Termination Types
- Resettable
- Optional Extended Temperatures
- Low Cost

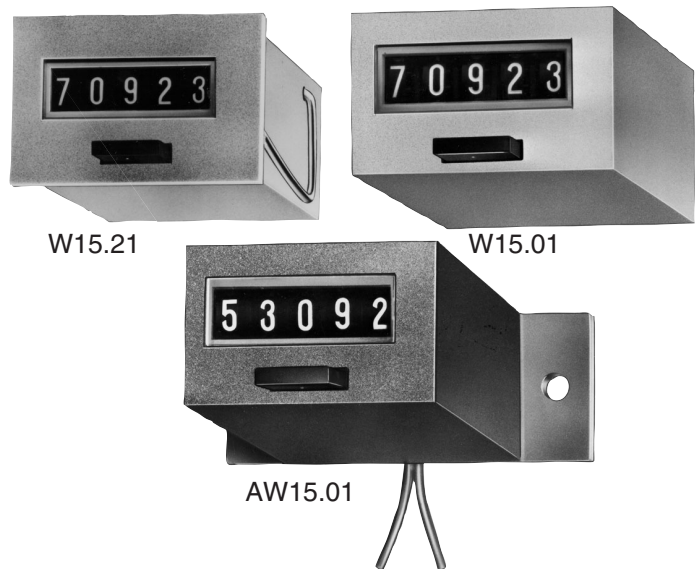

Applications:

W15 Series counters are well suited for battery operated traffic counters, vending machines, message accounting systems, and general event counting where a reset is required.

Description:

The W15 Series 5 digit counters combine low 60mW power and reset capability in a small housing just .790" high and 1.22" wide. The proven armature phase system combined with an anti-shock/vibration driving system provides a high degree of counting accuracy. Wear-resistant plastic insures a high rate of maintenance free service life.

Specifications:

Digits: Five 0.067" white on black.

Weight: 1.8 oz.

Operating Voltages:

3, 4, 6, 9, 12 VDC filtered $\pm 5\%$

4, 6, 12, 24, 48, 110, 185 VDC
unfiltered $\pm 10\%$.

12, 24, 48, 110, 220 VAC.

Reset: Manual, front push-button

Count Speed: 10 cps standard; 8 cps (low power-filtered)

Max. on Time: continuous

Temperature: +14°F to +122°F (-10°C to +50°C) standard.

-22°F to +158°F (-30°C to +70 °C) optional.

Termination: Wire leads 6" long or silver-plated pins 0.060" dia.

Color of Housing: Black

Approvals: CE Approved

Voltage	Model	Max. Pulse Speed	Pulse Duration Min.	Pulse Interval Min.	Power Consump. Approx.
VDC	Filtered	8	50 mS	75 mS	60 mW
VDC	Non-filtered	10	50 mS	50 mS	0.5W ($\leq 110V$) 1W (185V)
VAC		10	50 mS	50 mS	0.75 VA ($\leq 110V$) 1.5 VA (220V)

W15.01

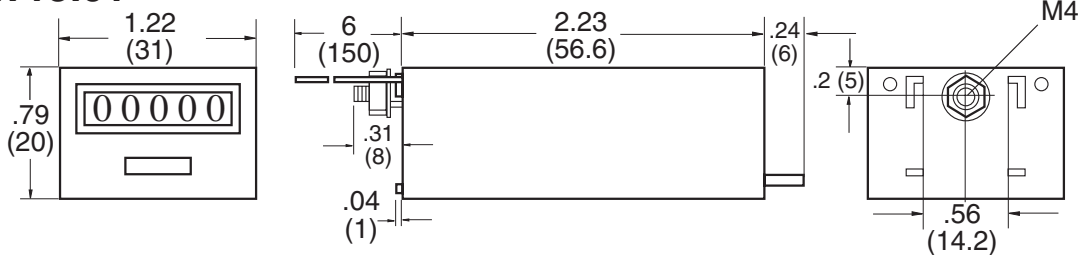

W15.21

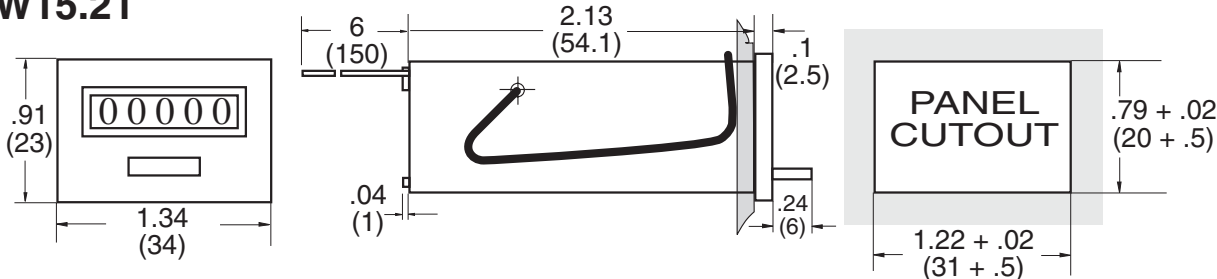

AW15.01

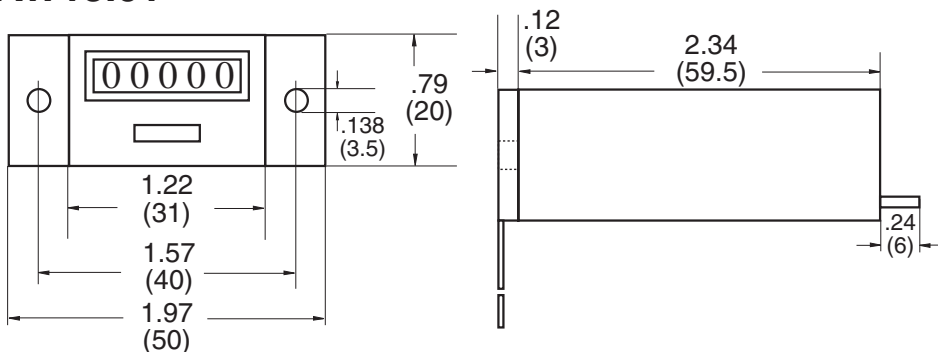

How To Order:

Series	Termination	Operating Voltage	Count Speed
EXAMPLE: W15.01	.3	5VDC	10CPS
AW15.01 = Base mount W15.01 = Rear stud mount W15.21 = Spring clip mount	.3 = .060" (1.5mm) Solder pins (not available with AW type) .2 = Wire leads 6" long	(specify, see count speed) DC: 3, 4, 6, 9, 12, 24, 110, 185 AC: 12, 24, 110, 220	8 CPS: 60 mW DC; available voltages 3, 4, 6, 9, 12 VDC 10 CPS: 500 mW DC; available voltages 4, 6, 12, 24, 110, 185 VDC 10 CPS: .75 VA; available voltages 12, 24, 110VAC; 1.5 VA, 220 VAC
Options	Extended temperature: -22°F to +158°F (-30°C to +70°C) add prefix "HT" to part number		

B Series

Industry Standard DIN Totalizing Counters

Features

- 5 and 6 Digits with Reset
- 8 Digits Non-Reset
- Secret Rear Reset Option
- Reversed Colored Number Wheels
- UL Listed, CE Certified
- Low Cost



Applications:

General purpose, high performance/low cost counter for monitoring manufacturing processes, flow totals, test cycles where accurate count must be displayed even when power is lost.

Description:

This counter series utilizes an all plastic housing and frame to achieve lower cost without sacrificing quality. Count life is 200 million minimum with optional speeds to 50 counts per second possible. Spring clip or two screw mountings are standard. Plug-in and rear stud mounting available on special order.

Specifications:

- Count Life:** 200 million.
- Numbers:** .160" (4mm) high.
- Housing:** Black plastic, 5, 6 or 8 digit,
- Connections:** .060" pins with push on connectors.
- Count Speed with DC:** 10, 25 count/sec. (optional 50 counts) per sec.
- Count Speed with AC:** 18 counts/sec.
- Impulse Ratio:** 60% on time, 40% off time (Min.).
- Operating Voltage:** 6, 12, 24, 48, 110, 220 VDC; 24, 48, 110, 220 VAC
- Operating Temperatures:** +23°F to +104°F (-5°C to +40°C);
- Approvals:** UL# E60420, CE Approved
- Weight:** 3 oz.
- Max. Count Time:** Continuous 50/50 or 60/40, on/off.

Count Input:

Voltage	Count Per Sec.	Time In Millisec On	Time In Millisec Off	Pulse Ratio	Power Consumption	
					Count	Reset
DC	5	120	80	3:2	85 mW	N/A
	10	60	40	3:2	1 W	
	25	24	16	3:2	2 W	
AC	18	27	27	1:1	2.9 VA	N/A

How To Order:

EXAMPLE: B 16 1 1 24VDC 25CPS

Series _____ B					
Digits _____ 15 = 5 digits 16 = 6 digits 18 = 8 digits					
Mounting _____ 0 = Non flange (for F1) 1 = Screw panel 2 = Spring clip 3 = Large screw panel					
Reset _____ 0 = Non-reset 1 = Manual push button 4 = Secret Reset					
Voltages (specify) _____ 6, 12, 24, 48, 110 and 220 VDC 24, 48, 110 and 220 VAC					
Count Speeds (specify) _____ 5, 10, 25 CPS DC 18 CPS AC					

Available Options (add to end of part number)

- K1B - Silicone cover #3 mount style
- F1B Frame - with socket box 945.2
0 Mount only
- 945.2 - Socket box
- F1DVS - Frame with locking cover & 945.2 socket box
- F1DK - Frame with knob closure cover & 945.2 socket box
- US - Key reset
- LT - Low temperature (-22°F to +115°F)
- HT - High temperature (+14°F to +140°F)
- 50 counts per second (specify)
- FL - 6" Wire Leads
- N7 - Explosion proof housing (see accessories section)

Mounting:

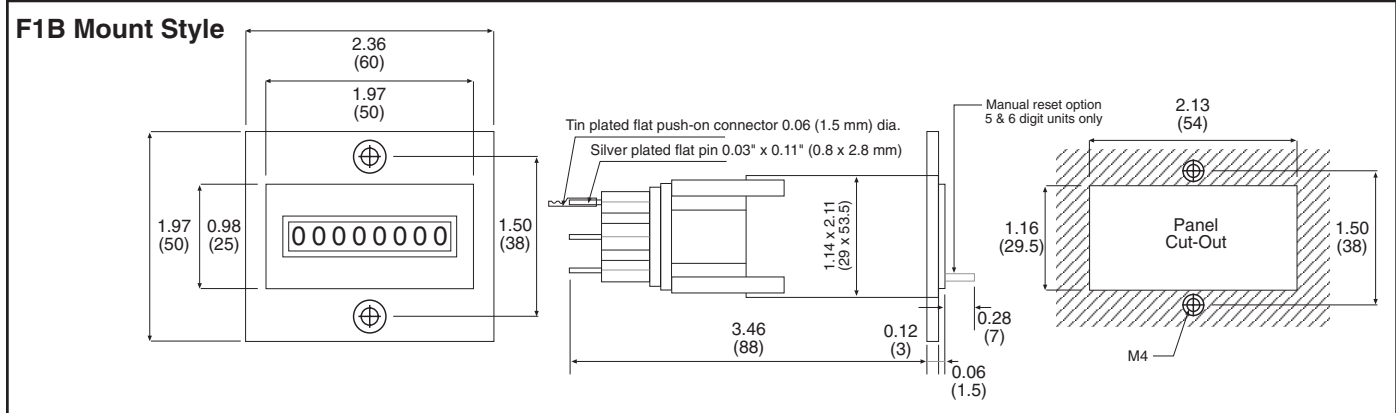
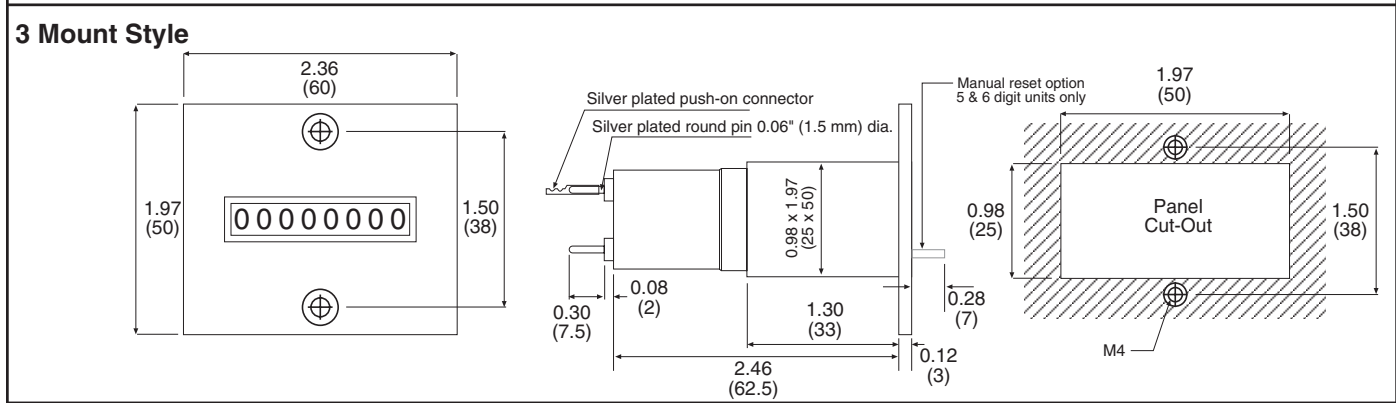
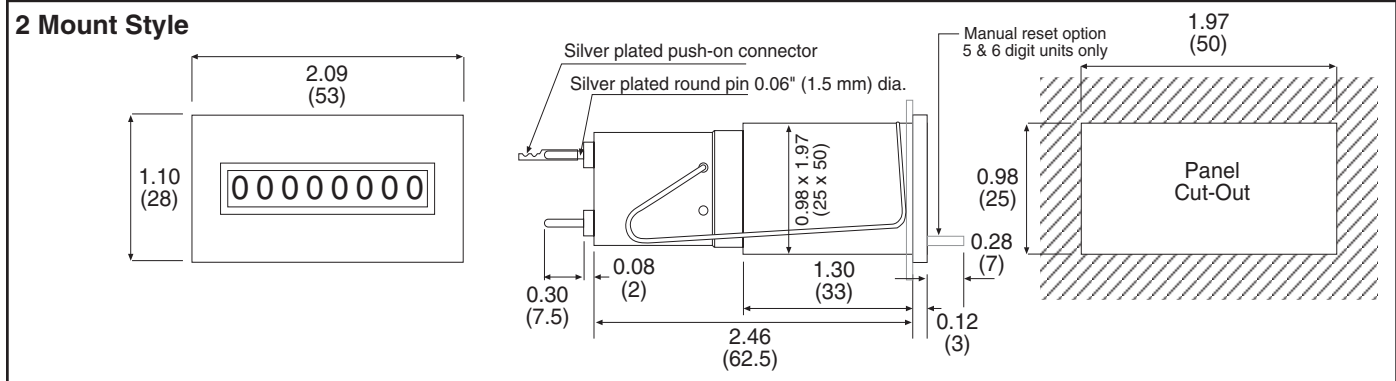
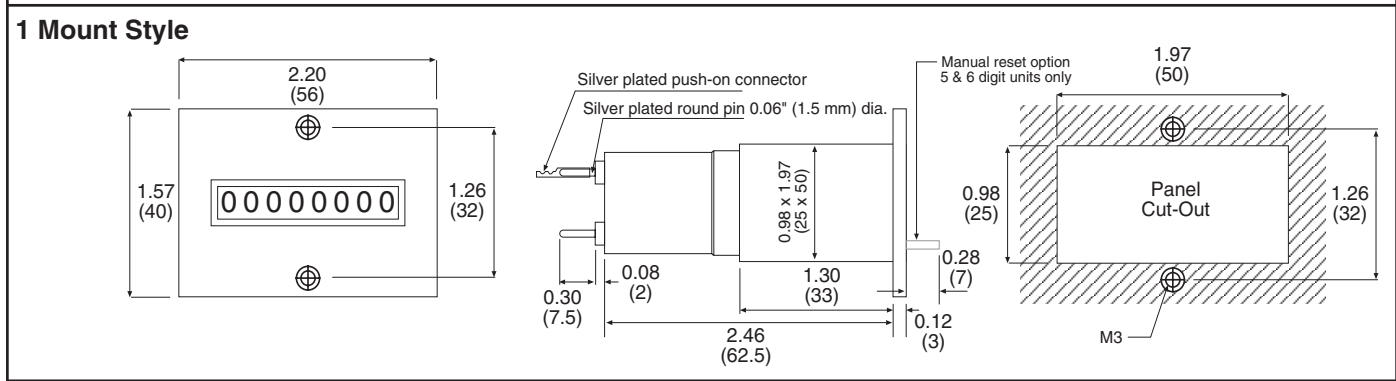
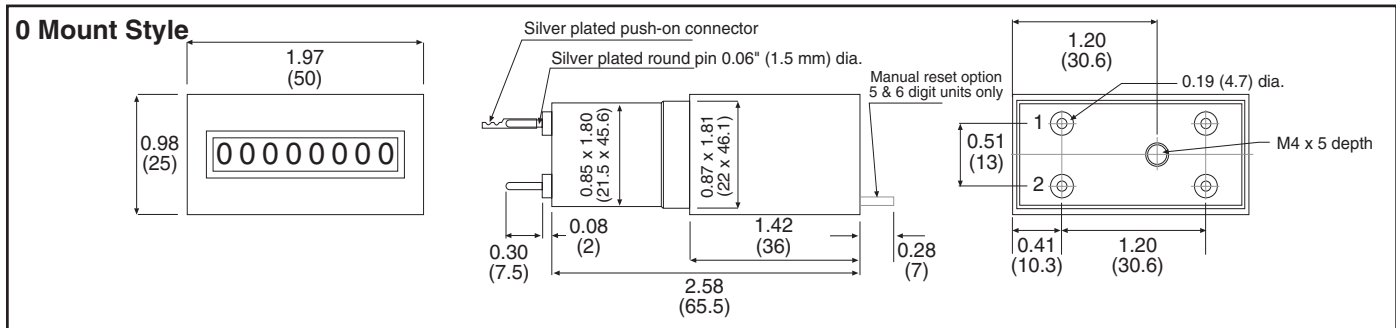

MK16 - 18

Electromechanical Totalizers 3, 4, 6 and 8 Digit

Features

- UL Listed, CE Certified
- Rugged Case
- Varied Mounting Styles
- 3, 4 and 6 Digits with Manual & Electric Reset
- Many Standard Voltages
- 250 Million Count Life, Minimum
- Many Options Available



Application:

Production counting, line counting (printers), events, fees, where count must be retained even if power is lost.

Description:

MK counters combine extra long count life, 250 million minimum, and absolute accuracy even with 10% voltage variation. Varied mounting styles. The spring clip mount gives the user a clean uncluttered panel. Installation is expedited by 0.020" x 0.11" quick push on connectors.

Count Input:

Voltage	Count Per Sec.	Time In Millisec On	Time In Millisec Off	Pulse Ratio	Power Consumption	
					Count	Reset
DC	10	50	50	1:1	1.2 W	9 W
	25	24	16	3:2	2 W	
	35	17	11	3:2	5.5 W	
AC	10	50	50	1:1	3 VA	14 VA
	18	27	27	1:1	3 VA	

Specifications:

Display: 6 digit with manual or electric reset; 8 Digit without reset

Digits: .160" white on black wheels.

Operating Voltages:

5, 6, 12, 24, 48, 110, 220 VDC;
12, 24, 48, 110, 220 VAC

Count Speed: 10, 25, 35 CPS standard VDC (40 or 50 CPS optional, see OPTIONS); 10, 18 CPS standard VAC only.

Temperature: +14°F to +114°F (-10°C to +45°C) standard

Housing: UL Listed, rugged, black, polycarbonate

Termination: Terminal pins 0.110" x 0.032 connectors supplied

Weight: 3 ounces

Max. Count Time: Continuous, 50/50 or 60/40 on/off pulse ratio.

Approvals: UL File#: E60420, CE Approved

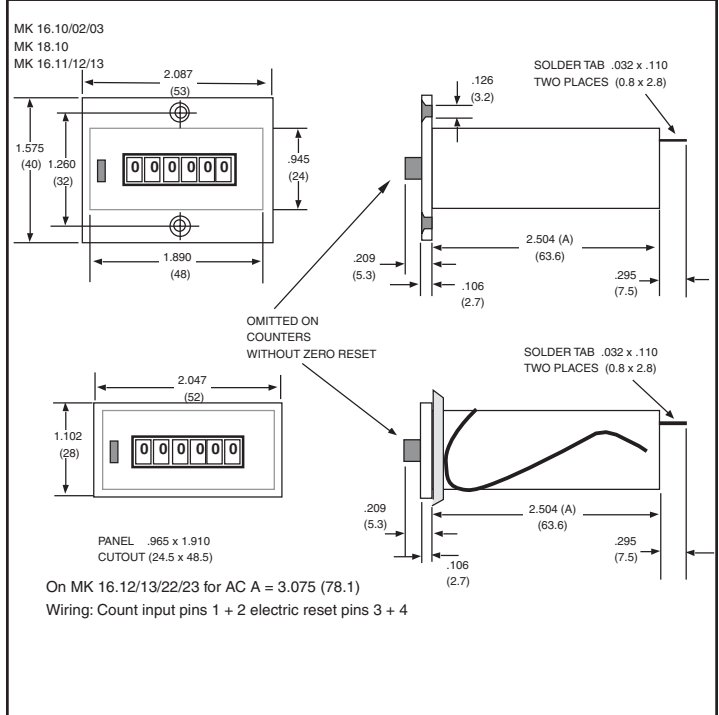
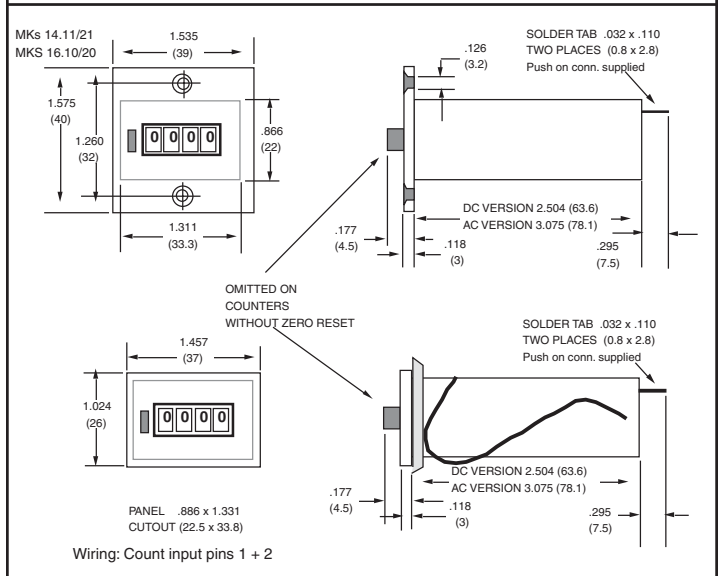
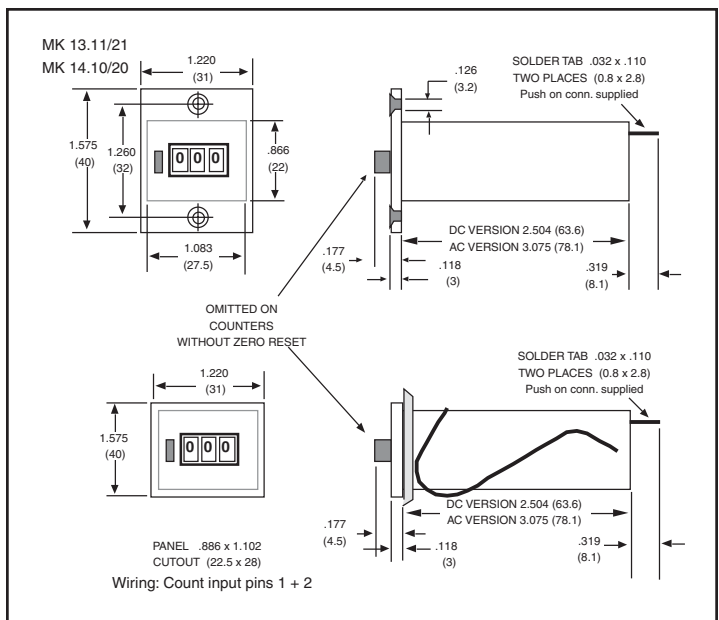

How To Order

EXAMPLE: MK16 1 2 24 VDC 25 CPS

Series	_____	_____	_____	_____
Mounting	_____	_____	_____	_____
Reset	_____	_____	_____	_____
Voltages (specify)	_____	_____	_____	_____
Count Speeds (specify)	_____	_____	_____	_____

- MKS14 = 4 digits non reset (1.09" wide cut out)
- MK14 = 4 digits with reset (1.32" wide cut out)
- MKS16 = 6 digits non reset (1.32" wide cut out)
- MK16 = 6 digits with/without reset (1.89" wide cut out)
- MK18 = 8 digits non reset (1.89" wide cut out)

- Mounting**
- 0 = Rear mount
 - 1 = Screw panel
 - 2 = Spring clip

- Reset**
- 0 = Non-reset
 - 1 = Manual push button
 - 2 = Electric (6 digit only)
 - 3 = Both (6 digit only)

- Voltages (specify)**
- 5, 6, 12, 24, 48, 110 and 220 VDC
 - 12, 24, 48, 110 and 220 VAC

- Count Speeds (specify)**
- 10, 25, 35 CPS DC
 - 10, 18 CPS AC

Available Options (add to end of part number)

- V - Manual reset guard (6 digit version)
- US - Spade key reset (6 digit version)
- SR - Secret reset (6 digit version)
- SL - Manual subtract lever (one count per stroke)
- ML - Magnifying lens
- M - SPDT microswitch operated by manual or electric reset (MK16.11/M)
- FL - 6" wire leads
- LT - Low temperature (-22°F to +115°F)
- HT - High temperature (+14°F to +140°F)
- 40 or 50 counts per second (DC only)
- Counts by 2's or 5's
- TB - Terminal block
- Z - Mounting stud (rear)
- Reverse Color Wheels-black on white, red on black
- Special engraving - faceplate
- K6 - Flexible silicone cover for #2 mount style
- A - Base mount ex: AMK 16.01
- K4 - Silicone Cover (mK14.21)

ENCLOSURES:

- N7 - Explosion proof (see accessories section)
- N12 - Oil and dust proof
- N4 - Weather and water proof
- Add "R" for external Reset Button
- (Unit must be ordered with Electric Reset)

KAL-DIN

Features

- UL, CSA Listed, CE Certified
- 8 Digits Standard
- Meets NEMA 4X and IP65 Ratings
- Long Life Lithium Battery
- 10 kHz Count Speed
- Plug-on Adapter with Terminal Block and AC Pulsing
- Slow Speed Input for Contact Closures
- High Speed Input for Sinking Inputs from a Max. of 18VDC Without Module

Description:

These are small, lithium battery powered, totalizing counters that are panel mounted. The counters are designed as replacements for standard electro-mechanical counters. They use the latest custom CMOS technology and incorporate an 8 digit, 0.276" high, LCD display.

The KAL-DIN operates from a long life lithium battery (life 10 years) and can be operated from contact closure or high speed electronic devices. No separate alkaline batteries are required. The front reset button can be disabled if desired.

Connections are via .025" (6.35mm) square posts. Push on connector with 9" (229mm) leads are supplied with unit.

When installed, with the gasket provided, the unit meets NEMA 4X/IP65 ratings from the front.

Use the KAL-DAC/DC adaptor to pulse from 5 to 240 volts AC or DC.

Use the KAL-DTB adaptor for screw terminals.

Mounting:

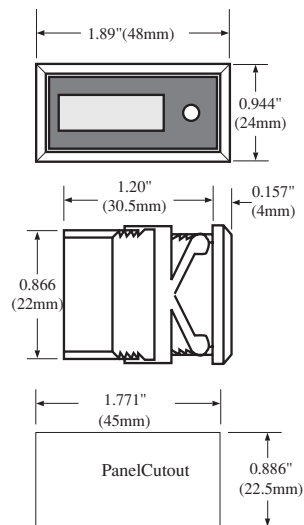

Adaptors (included)

KAL-DP1X2

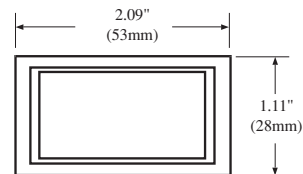

KAL-DP1

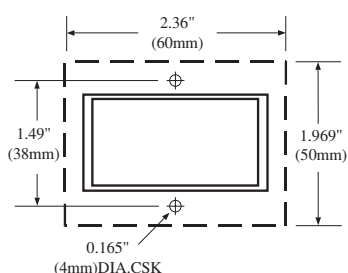

Miniature, Low Cost, LCD, Electronic Counter



Specifications:

Power: Internal lithium battery

Display: 8 digit black LCD, Digit size 0.276" (7mm) high

Reset: Panel or remote

Temperature Range: 14 to 140°F (-10 to 60°C)

Signal Input:

Common (Pin 1)

Manual Reset Enable (Pin 2)

Link to Common to enable front panel reset key

External Reset (Pin 3)

Contact closure/open collector neg. edge triggered, 0.7V threshold, minimum pulse length 15mS.

Slow Speed Count Input (Pin 4)

Contact closure/open collector, minimum pulse length 15mS, 30Hz max. negative edge triggered,

Low: < 0.7V,

High: 3 to 18 V or open.

High Speed Count Input (Pin 5)

Open collector input, 10KHz max., min. pulse length 50µS. negative edge triggered,

Low: < 0.7V,

High: 3 to 18 V or open.

TTL/CMOS compatible.

Approvals: UL File: E135458, CSA File: LR9602, CE Approved

Material: ABS Plastic.

Battery Life: 10 years (calculated)

Connection: 5 pin, plug in connector with 9" (229mm) leads supplied with counter.

Sealing: Front Panel (without adaptors) sealed to NEMA 4X/IP65 when used with clip mount and gasket provided.

Mounting Adaptors: KAL-DP1x2 for 1" x 2" cutout and KAL-DP1 for screw mount are supplied.

WIRING DIAGRAM

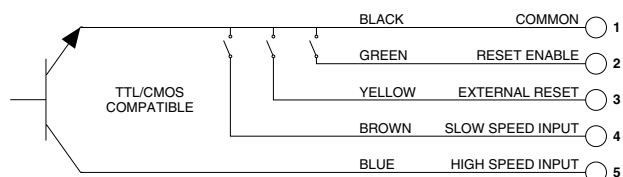

TERMINAL BLOCK MODULE

Description -- KAL-D TB

(For screw terminal connection with standard pulse characteristics)

Pin numbers shown on terminal block correspond to wire lead numbers.

Two Pins #1 are internally connected.

DO NOT CONNECT KAL-D TB TO AC VOLTAGE

5-240 VOLT INPUT MODULES

Description -- KAL-D AC/DC (Counter)

KAL-DTIME AC/DC (Timer)

The KALD AC/DC Module enables the KALD to accept 5-240 VAC/DC input signals. (The KAL-DTime AC/DC is used for the KAL-DTIME series). The module snaps into the back of the counter. The circuitry allows various voltage pulses to be used for counting and provides opto-isolation of 2500V.

KAL-D AC/DC (Counter)

SPECIFICATIONS:

Signal Inputs:

18 Hz max. (15 msec. pulse width min.)

5 to 48 VAC/DC

Low: < 1.5 VAC/DC or open

High: 5 to 55 VAC/DC

48 to 240 VAC/DC

Low: <15 VAC/DC or open

High: 48 to 264 VAC/DC

Input Impedance:

5 to 48 VAC/DC - 10K ohms

48 to 240 VAC/DC - 58.5K ohms

Reset:

Dry contact closure only.

15msec. min. pulse.

Temperature Range:

Same as KAL-D series

Terminal Block (TB) Adaptor Connections

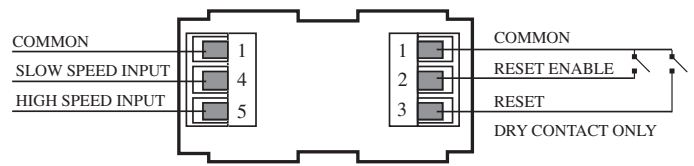

Dimensions for AC/DC Adaptor and Terminal Block

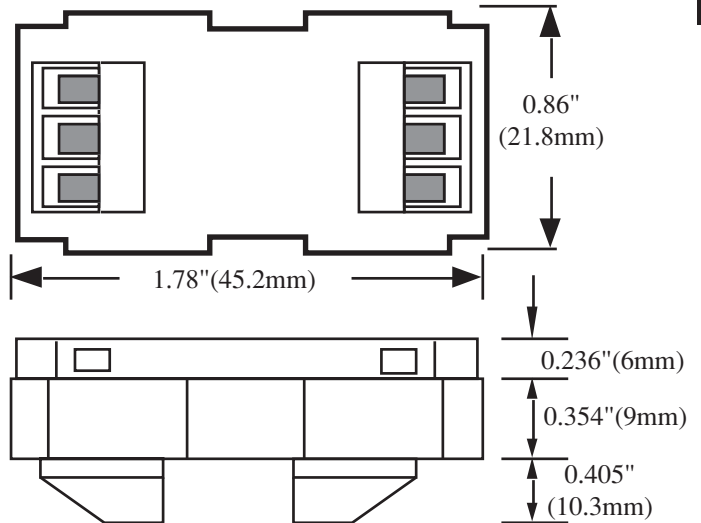

AC/DC Adaptor Connections

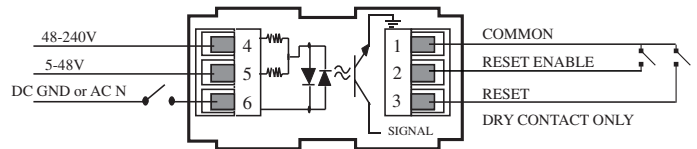

NOTE:

Jumper terminal 5 to terminal 6 to raise the low threshold to 25V for triac inputs or when low voltage does not reach 0V. Connect input to terminals 4 & 6.

It may be necessary to place a 10 kΩ 7W resistor across terminals 4 & 6 to bring voltage below 25V.

How To Order:

- KAL-D 8 digit counter with 10 yr battery
- KAL-DAC/DC 5-240V AC/DC input module
- KAL -DTB Terminal block adaptor

Accessories

- N7 - Explosion proof housing (see accessories section)
- E200 - Outdoor Enclosure (see accessories section)

KAL-DIN AS

Features

- UL, CSA Listed, CE Certified
- 8 Digits Standard
- Meets NEMA 4X and IP65 Ratings
- Long Life Lithium Battery (10 years)
- 10 kHz Count Speed
- Add and Subtract Counter

Description:

The KAL-DAS is a small add-subtract counter suitable for panel mounting and is powered by an internal lithium battery with an operating expectancy of 10 years. The counter is designed as a replacement for standard electro-mechanical counters. It has a front panel reset button which, for security, is enabled by an external connection to the rear of the unit. Based on the latest CMOS technology, these units incorporate an 8 digit, 0.276" character height, high contrast, LCD display.

The KAL-DAS will add and subtract pulses at count frequencies up to 10 kHz displaying 99999999 when it counts below 0. No separate alkaline batteries are required.

Connections are via .025 inch square posts (push on connector with 9" leads supplied with units).

When installed, with the gasket provided, the unit meets NEMA 4X/IP65 ratings from the front.

Specifications:

Power: Internal lithium battery

Display: 8 digit black LCD, Digit size 0.276" high

Reset: Panel or remote

Temperature Range: +14 to 140°F (-10 to 60°C)

Signal Input:

COMMON (Pin 1)

RESET ENABLE (Pin 2)- Link to COMMON to enable front panel reset key.

Miniature, Low Cost Add-Subtract Counter



EXTERNAL RESET (PIN 3)-external via dry contact or open collector, negative edge triggered, 0.7 V threshold. Minimum pulse 15 mS.

DIRECTION INPUT (Pin 4)-Electronic input, TTL/CMOS compatible.

Add: open or 3-18 VDC

Sub: Contact to Pin 1 or <0.7V

Direction level must precede count input by 5µs for valid operation.

COUNT INPUT (Pin 5)-Electronic input, 10KHz max., negative edge triggered,

Low: < 0.7V,

High: 3 to 18 V or open.

ON/OFF pulse 50µS TTL and CMOS compatible (18 V max.)

NOTE: All inputs have Schmitt characteristics.

Approvals: UL File: E135458, CSA File: LR96702, CE Approved

Material: ABS

Weight: 1.7 oz.

Battery Life: 10 years (calculated)

Connection: 5 pin, plug in connector with 9" leads supplied with counter.

Sealing: Front Panel sealed to NEMA 4X/IP65

Mounting:

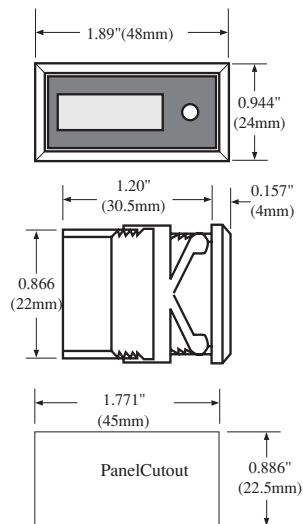

Adaptors (included) KAL-DP1X2

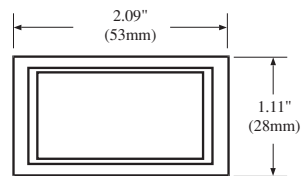

KAL-DP1

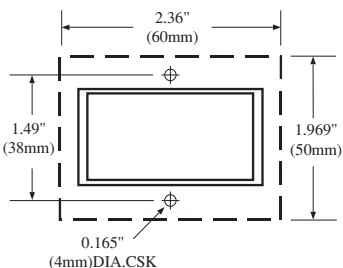

KAL-DAS WIRING DIAGRAM

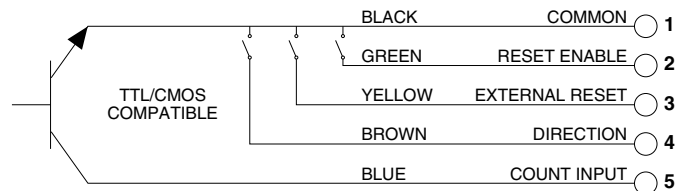

KAL-DQUAD WIRING DIAGRAM

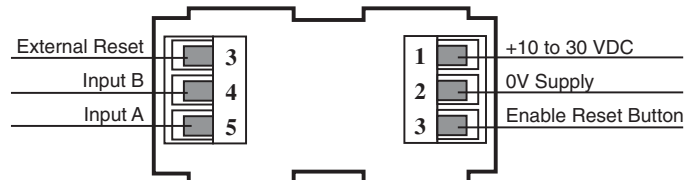

How To Order:

- KAL-DAS 8 digit add/subtract counter
- KAL-DTB Snap-on terminal block adaptor
- KAL-DQUAD Snap-on quadrature input adaptor

Accessories

- N7 - Explosion proof housing (see accessories section)
- E200 - Outdoor Enclosure (see accessories section)

130K-133K

Battery Powered Counters with LCD Display

Features

- Low price and high efficiency
- Large (8 mm) 8-digit LCD display,
- Optional backlighting
- Various counting modes: up /down, differential, quadrature and pulse doubling
- High voltage input for 10 to 260 V AC/DC voltage pulses
- NEMA4/IP65 Front Panel
- Screw terminals, RM 5 mm
- Lifetime of the battery approximately 8 years
- Locking of the reset key
- Operating temperature -10 to $+60$ °C



- All versions for positive or negative counting edge
- Debounce filter function for counting with mechanical contacts.

Technical data

Power supply: non-replaceable lithium battery (lifetime approximately 8 years at 20°C)

Backlighting: external electrical source 24 V DC \pm 20 %, 50 mA

Display: LCD, 8 decades, 8 mm high characters

Mode:
a. adding or subtracting (selectable)
b. counting direction
c. differential counting
d. phase discriminator

Display range: -9999999 to 9999999 , with overflow display

Reset: manual and electrical

Counting inputs:

A. Standard DC Input (max. 30 V DC)

Slow counting input: max. 30 Hz NPN

Fast counting input: max. 12 kHz (PNP), 7 kHz (NPN)

Switching level:

NPN: Low: 0 to 0,7 V, High: 3 to 30 V DC

PNP: Low: 0 to 0,7 V, High: 4 to 30 V DC

B. High Voltage Input (10 to 260 V DC/AC)

Counting input: Optocoupler input, max. 30 Hz

Min. pulse time: 16 ms

Switching level: Low: 0 to 2 V DC/AC, High: 10 to 260 V DC/AC

C. Counting direction switching (only DC-version)

Mode : see order table

Contact input:

Open Collector NPN (switching at 0 V DC)

Switching level:

NPN: Low: 0 to 0,7 V, High: 3 to 5 V DC

D. Reset Input (only DC and high voltage)

Minimum pulse time:

DC: 50 ms, high voltage: 16 ms

Contact input DC*:

NPN: Low: 0 to 0,7 V, High: 3 to 30 V DC

High voltage input: 10 to 260 V DC/V AC

E. Electrical reset key locking (for DC and AC)

Contact input:

Open Collector NPN (switching at 0 V)

Switching level:

NPN: Low: 0 to 0,7 V, High: 3 to 5 V DC

Interference emissions:

EN 55011 Class B, EN 61000-6-2 EN 61010 Section 1 (only AC versions)

Housing: dark grey RAL 7021

Operating temperature:

-10 to $+55$ °C

Ambient temperature:

-10 to $+60$ °C

Storage temperature:

-20 to $+70$ °C

Protection: NEMA4/IP65 front

Weight: approximately 50 g

* and high voltage on Codix131 and Codix132

Dimensions:

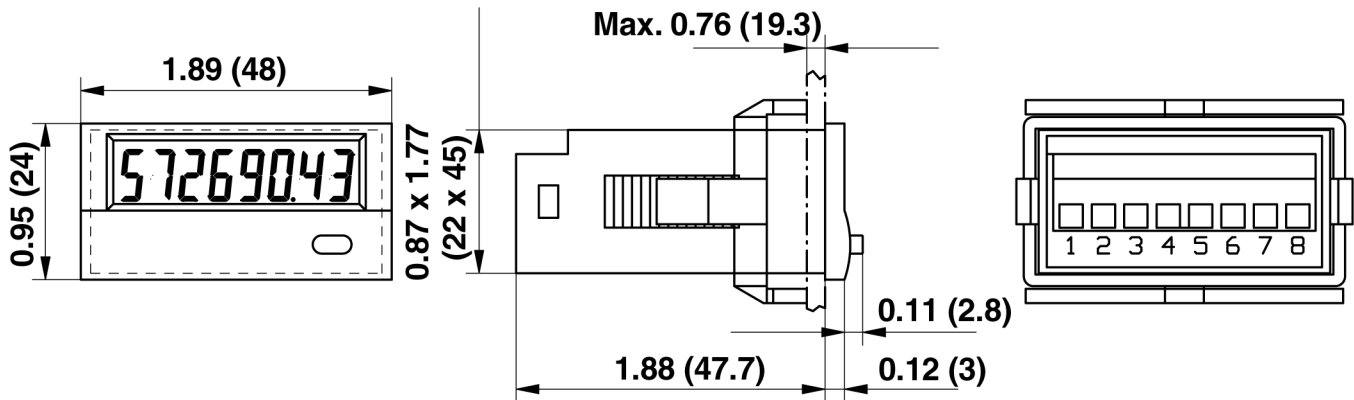

Order Table

Type	Input type	Counting inputs							
		INP A				INP B			
130K.012.8x0	Count ¹⁾	0 ... 0,7 V DC	count	NPN	7 kHz	0 ... 0,7 V DC	count	NPN	30 Hz
130K.012.8x2		4 ... 30 V DC	count	PNP	12 kHz	0 ... 0,7 V DC	count	NPN	
130K.012.8x3		10 ... 260 V AC/DC	count	AC/DC	30 Hz	10 ... 260 V AC/DC	reset	AC/DC	—
131K.012.8x0	Cnt.Dir ²⁾ /Up.Dn ³⁾	0 ... 0,7 V DC	count	NPN	7 kHz	0 ... 0,7 V DC	count/direction	NPN	7 kHz
131K.012.8x1		4 ... 30 V DC	count	PNP	12 kHz	4 ... 30 V DC	count/direction	PNP	12 kHz
131K.012.8x3	Up.Dn ³⁾	10 ... 260 V AC/DC	count	AC/DC	30 Hz	10 ... 260 V AC/DC	count	AC/DC	30 Hz
132K.012.8x3	Cnt.Dir ²⁾	10 ... 260 V AC/DC	direction	AC/DC	30 Hz	10 ... 260 V AC/DC	count	AC/DC	30 Hz
133K.012.8x0	Quad ⁴⁾ /Quad ⁵⁾	0 ... 0,7 V DC	channel A	NPN	3 kHz	0 ... 0,7 V DC	channel B	NPN	3 kHz
133K.012.8x1		4 ... 30 V DC	channel A	PNP	6 kHz	4 ... 30 V DC	channel B	PNP	6 kHz

X: 5 = no backlight
X: 6 = with backlight

1): one-channel, adding or subtracting counting
2): counting input with counting direction input
3): one adding and one subtracting counting input (differential mode)

4): Phase discriminator for incremental encoders with single processing
5): Phase discriminator for incremental encoders with double processing

Accessories:

N7 - Explosion proof housing (see accessories section)
E200 - Outdoor Enclosure (see accessories section)

MICRO-KAL

Miniature, LCD, Self Powered Electronic Totalizer

Features

- Self Powered (3.5 years)
- 4 Digits, 0.24" Character Height
- High Contrast LCD Display
- Simple to Install
- Integral De-bounce Circuitry

Applications:

- Applications where no power is available
- Amusement machines
- Portable equipment
- Dispensing machines
- Luggage lockers
- Copiers and printers
- Ticket machines
- Utility meters

Description:

The Micro-KAL1 and Micro-KAL2 counters are based around the same miniature 4 digit self-powered totalizer. The Micro-KAL1 features flying leads for remote contact closure input; the Micro-KAL2 has a magnetic reed switch attached. It also operates in conjunction with a small button magnet which can be supplied to special order. The Micro-KAL1 increments the count when the contact is open. The Micro-KAL2 increments the count when the magnet is moved away. They may be panel mounted with the optional bezels supplied.

Specifications:

Supply Voltage: 1.5V button cell type 386 or SR43.

Expected battery life: 3-4 years at 68° F (20° C).

Display: 4 digit black LCD, .24" (6mm) characters.

Count range: 9999 display rollover to 0.

Count input: 18 Hz maximum, contact closure. Operates on contact opening.

Reset: Reset to zero on insertion of battery.

Operating temperature: 32° to 122° F (0° C to +50° C).

Storage temperature: 32° to 140° F (0° C to +60° C).

Material: Clear poly-carbonate, black ABS bezel.

Environmental protection: IP40/DIN40050.

Weight: .26 ounces (7.5 grams).

Lead length: 9.45" (240mm).

Approvals: CE Approved



Dimensions:

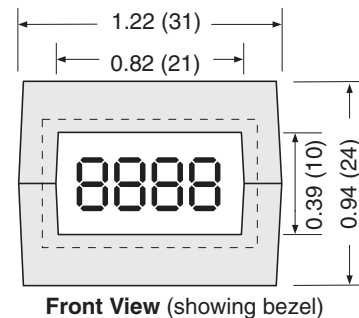
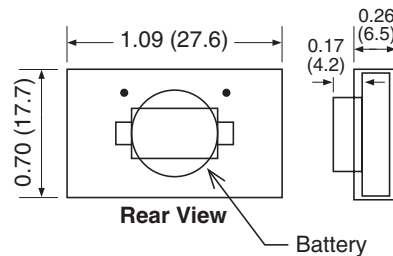

How To Order:

- Micro-KAL1 Totalizer with flying leads
- Micro-KAL2 Totalizer with reed switch
- M0 Red Magnet for Micro-Kal2

MINI-KAL

Features

- UL, CSA Listed, CE Certified
- 6 and 8 Digit models
- PC Board Mountable
- Low Power Consumption
- 10 kHz Count Speed
- Easily Integrated Into OEM Systems
- Add -Subtract (AS Version)

MINI-KAL1

MINI-KAL1AS

Description:

The MINI-KAL series of small, easy-to-mount LCD counters can be mounted directly to a PC board, or, with SLIM-KAL, through two screw holes in a panel. They are useful for counting applications where space is tight, and where OEM instrument makers want a pre-designed counter.

The MINI-KAL is a PC board mountable, 6 digit counter which counts up to 10 kHz, and consumes less than 15 μ A of current. Connections are via four pins on 0.1 inch centers.

The MINI-KAL-DAS is a small 6-digit electronic add/subtract totalizing counter, based on the latest CMOS technology and incorporates a 6-digit 6mm character height, high contrast LCD display.

The MINI-KAL-DAS has been specifically designed to use minimal power—quiescent current less than 5 microamps making the unit ideally suited in low power battery applications. The counter will add and subtract count pulses at input frequencies up to 10 kHz making the unit suitable for use in position, length and distance measuring applications.

MINI-KAL 1

Specifications:

Voltage: 3 VDC (\pm 0.6V)

Current: 15 μ A

Display: 6 digit, LCD, 0.2" high

Temperature Range:

Operating: +14 to 122°F (-10 to 50°C)

Storage: -14 to 140°F (-20 to 60°C)

Signal Inputs:

COUNT INPUT: Electronic 10 kHz max. (min. on/off 50 μ sec)
Negative edge triggered, 0.7 V threshold. Max. input 24 VDC

RESET: Electronic Negative edge triggered 0.7 V threshold. (min. on/off pulse 20 mS)

Material: Clear polycarbonate

Weight: 0.25 oz.

Miniature, Low Cost Electronic Counter



MINI-KAL1AS

Specifications:

Voltage: 3VDC \pm 0.4V (VDD)

Current: 5 μ A typical

10 μ A maximum at 10 kHz

Display: 6 digit 0.2" character height black LCD

Temperature Range:

Same as MINI-KAL1

Signal Inputs:

COUNT INPUT: Electronic 10 kHz max. (min. on/off 50 μ sec) Negative edge triggered, 0.7V threshold, TTL/CMOS compatible.

DIRECTION: Electronic input, TTL/CMOS compatible.

Add—logic 1 (VDD)

Subtract -logic 0 (0 to 0.7 V)

RESET: Negative edge triggered 0.7V threshold, minimum pulse length 50 μ S.

Material: Clear PETP

Weight: 3 oz. (75 grams)

Sealing: IP40/DIN40050

Dimensions: 27x175x65 mm

MINI-KAL2AS

Description:

The MINI-KAL2 AS add/subtract totalizing counters operate from an external 3VDC supply and feature an 8 digit high contrast LCD display with a character height of .315". The unit is suitable for PCB mounting and is available with or without the front panel reset button. Inputs are provided for count direction and external reset. The counter will add and subtract count pulses at input frequencies up to 10 kHz making it suitable for use in position length and distance measuring applications. With power consumption less than 10 μ A, typically 5 μ A, this unit is ideally suited in portable battery powered applications.

MINI-KAL2AS

Specifications:

Voltage: 3VDC ± 0.4V (VDD)

Current: 5µA typical, 10µA max. at 10 kHz

Display: 8 digit 8mm character height black LCD

Temperature Range:

Operating: +14 to 122°F (-10 to 50°C)

Storage: -14 to 140°F (-20 to 60°C)

Signal Inputs:

COUNT INPUT: Electronic input 10KHz max., negative edge triggered, 0.7V threshold, minimum pulse length 50 µS, TTL/CMOS compatible.

COUNT INPUT: Contact closure/open collector input, 30 Hz max, negative edge triggered, 0.7V threshold, minimum pulse length 15 mS.

DIRECTION: TTL/CMOS compatible.

Add—logic 1 (VDD)

Subtract—logic 0 (0 to 0.7 V)

EXTERNAL RESET: Contact closure/open collector input, negative edge triggered, 0.7V threshold, minimum pulse length 15 mS.

Connections: 6 PCB mounting pins on a 0.1 inch pitch.

Approvals: UL File: E135458, CSA File: LR96702, CE Approved

Wiring:

MINI-KAL1 Hookup

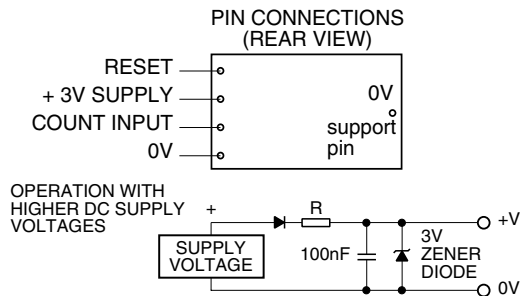

MINI-KAL-DASH Hookup

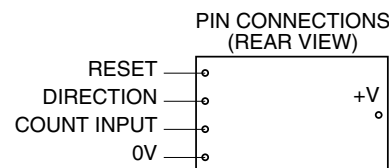

MINI-KAL2AS Hookup

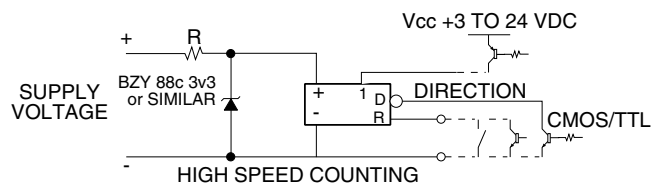

Mounting:

MINI-KAL1 SERIES Mounting

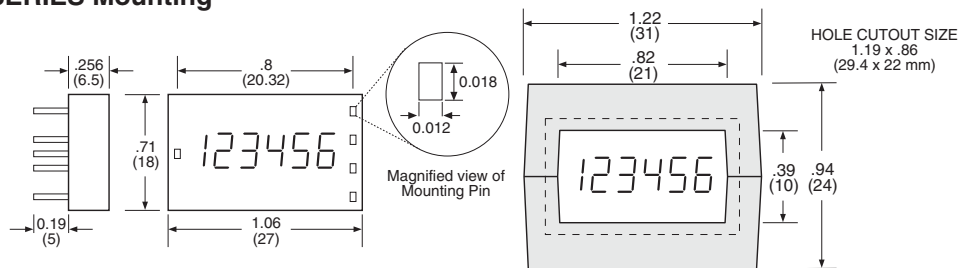

MINI-KAL1 SERIES with KALPM1 panel adaptor clips into panel .050 to .125 thick

MINI-KAL2AS Mounting

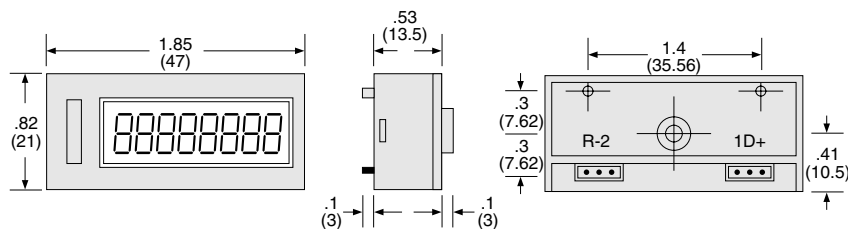

How To Order:

- MINI-KAL1 6 digit adding counter
- MINI-KAL1AS 6 digit add/subtract counter
- KALPM1 MINI-KAL panel mount adaptor
- MINI-KAL2AS 8 digit add/subtract counter
- MINI-KAL2ASNR Non-reset MINIKAL2AS (non-reset)

* For no reset, add "NR" to part number

SLIM-KAL

Miniature, Low Cost Electronic Counter

Features

- 8 Digit Display
- Panel Mount - Just 2 Screw Holes Needed
- Low Power Consumption
- Contact Closure/ NPN Transistor Input

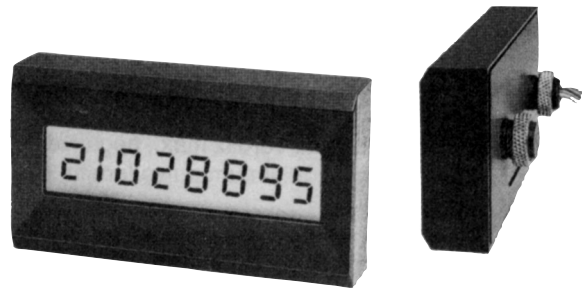

Description:

This totalizing counter replaces mechanical counters. It offers high reliability, better readability, noiseless operation and easy, two-hole mounting.

The SLIM-KAL has two critical features. They are:

1. Easily mounted on a panel with only two screws.
2. Displays 8, very large digits.

Specifications:

Power: 6-110 VDC, 6-240 VAC

Current: 50 μ A-5VDC

Display: 8 digit, LCD, 0..472" (12 mm) high

Temperature Range:

Operating: +14 to 122°F (-10 to 50°C)

Storage: -14 to 140°F (-20 to 60°C)

Input: Contact closure and/or NPN transistor inputs for count and reset.

Count Rate: 30 Hz maximum speed

Approvals: CE Pending

Dimensions—SLIM-KAL

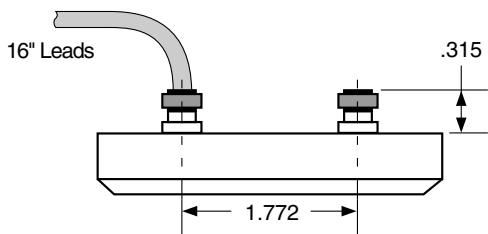
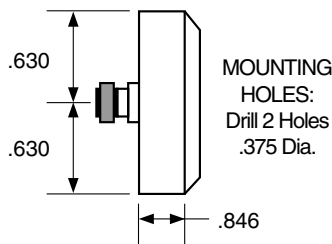
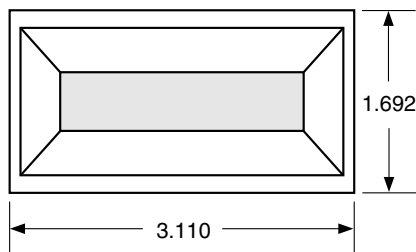

Connection Details:

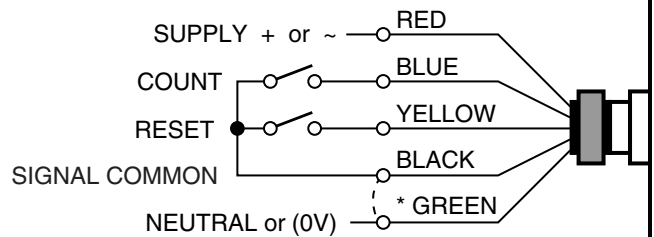

* Jumper Black to Green for voltages less than 48V DC or AC

APPLICATION NOTE FOR LOGIC INTERFACE ONLY

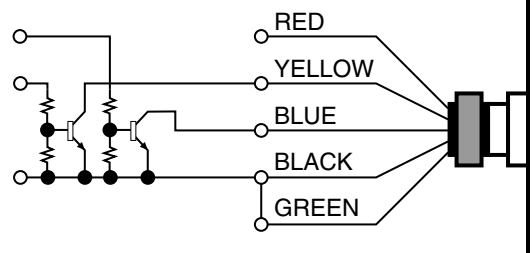

How To Order:

SLIM-KAL 8 digit counter

XL-10 Counter

Electronic Totalizer

Features

- 6 Digit Display
- 5-260 VDC or VAC Count Inputs
- Switch Closure Inputs
- 10 Year Battery Operation
- 2-Wire Hook-Up
- Backlit Display (optional)
- Decimal Point
- Heated (optional)



Applications:

Perfect when a self-powered electronic LCD totalizer is needed. Applications include packaging machinery, flow totalization, production, test equipment, and any other requirement where continuous count display and simple hookup and installation are important.

Description:

The XL-10 is a 6 digit liquid crystal display totalizing counter designed for use where older electro-mechanical counters have been the standard. It also is attractively priced for new applications requiring utmost reliability even during a power outage.

Packaged in a handsome black anodized extruded housing, the XL-10 features high contrast LCD digits 1/2" high designed for clear viewing at all angles in the brightest of light. The unit is powered by a lithium battery designed for 10 years of continuous use. A converter is available for back lighting in applications where ambient light is limited or night viewing required. In addition, the XL-10 can be ordered with a built-in heater for use in applications to -40° C. Standard operating temperatures are -20° to +55° C.

Two mounting styles, wire lead termination, and KEP support make the XL-10 the perfect electronic totalizer for a wide variety of applications where long life and reliability are

key.

Specifications:

Count Speed: 0 to 50 CPS.

Count Input:

H: High Impedance - Any AC or DC voltage between 12 and 260 Volts.

L: Low Voltage - Any AC or DC voltage between 5 and 11 Volts.

C: Contact Closure - For simple switch closure inputs.

Reset:

Standard: Push-button.

Optional: Key operated or Remote Reset via contact closure.

No. of Digits: 6 digit LCD.

Digit Size: 1/2" high.

Power Supply: Built-in lithium battery designed for 10 year operation. No external power source required for applications to -20° C.

Mounting: Wall or panel.

Termination: 10" long color coded wire leads.

BASE MOUNT

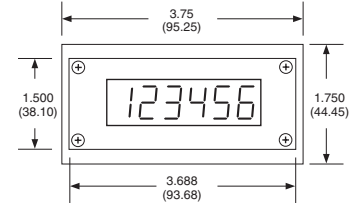
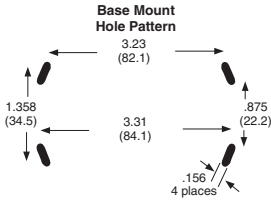
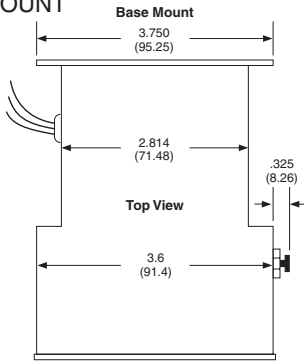

PANEL MOUNT

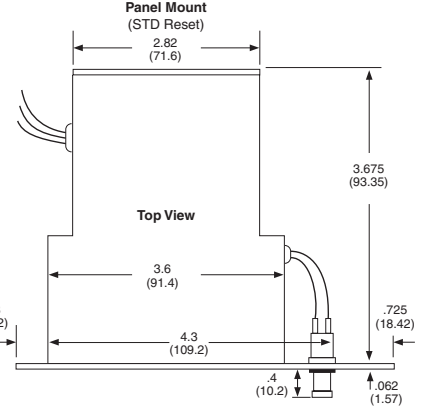
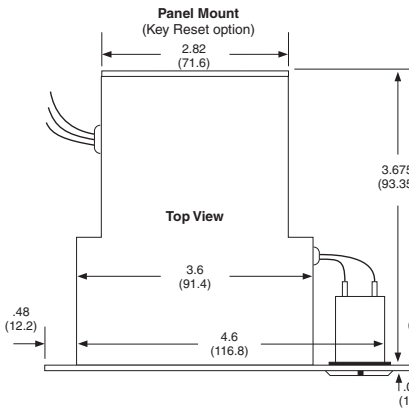
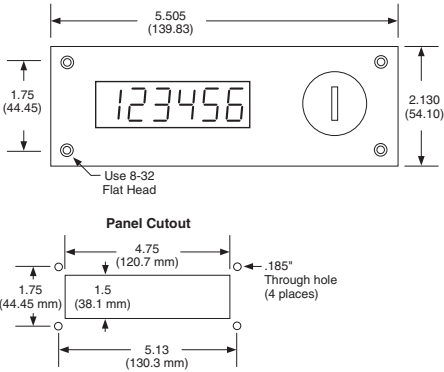

Wiring:

Count Input H (High Impedance)

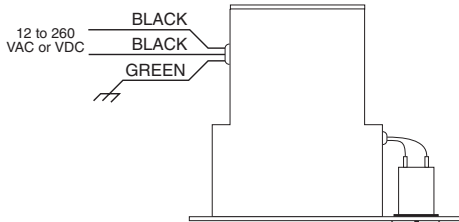

Count Input L (Low Voltage)

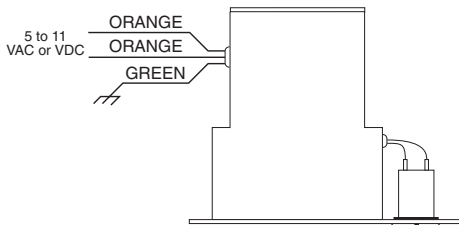

Count Input C (Contact Closure)

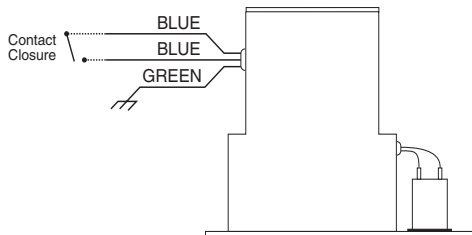

How To Order:

EXAMPLE: XL-10 P 1 H(12DC) 50CPS DP1 LT

Series	XL-10
Mounting	P=Panel (reset on front) B=Base (reset on side)
Reset	1= Standard reset (see Mounting) 2= Keyswitch (panel mount only)
Count Input	H ()=Pulse inputs, specify voltage, (AC or DC, 12-260 Volts) L ()=Low voltage pulse inputs, (AC or DC, 5-11 Volts) C ()=Simple switch closure
Count Speed (Maximum)	50 CPS=standard (for higher count speeds, consult factory)
Decimal Points	DPX=No decimal point DP1=xxxxx.x DP2=xxxx.xx DP3=xxx.xxx DP4=xx.xxxx DP5=x.xxxxx
Options	BL= Back Lighting LT= Heated for low temp applications (requires ext. 12VDC) RR= Remote Reset

K Series

Miniature Electronic Counter

Features

- Add and Subtract Counter
- Accepts Simultaneous Inputs
- Built-In Battery Backup
- 8 Digit LED Display
- Optically Isolated Inputs
- Accepts AC or DC pulses & Switch Closure Inputs
- 1" x 2" (25 x 50 mm) Standard Case Size



Applications:

Ideal when small size and fast count speeds are needed. Uses include piece part totals, flow totalization and other OEM machinery needing a simple LED totalizer.

Description:

The K series is a 4 or 8 digit totalizer electronic counter. Its unique count input accurately registers simultaneous overlapping pulses, is optically isolated, and accepts counts at speeds up to 100 kHz. Further, the K series has a "built-in" battery to protect against power failures, can be powered with DC voltage and pulsed with AC or DC voltages, and is built with CMOS L.S.I. circuitry. In addition, all K series 4 digit counters have open collector logic level zero output as an optional feature. The K series 5-30 VDC power, small size and standard built-in battery makes it the perfect counter for those demanding applications where good looks, long life, and a secure count are important.

Specifications:

Count Speed: 0-100 kHz

Reset: Follows count input selected above, overrides count and triggers on leading edge.

Number of Digits: 8; at 99999999 all digits "roll" to zero for continued counting.

Digit Size .170" high standard.

Power Supply: 5-30 VDC regulated or unregulated.

Current Consumption: 80 milliamps with all 8 digits lit to number 8.

Power Interruptions: Built-in battery. Power may be interrupted for up to 1 week without loss of count. Counter may be stored for six months before 24 hours operation will be needed for battery recharge. While on standby, display blanks to conserve energy.

Count Input: Five inputs may be selected.

SP: Simultaneous Pulses - Positive going signals from 5 V to 30 VDC. Simultaneous overlapping add and subtract pulses are accurately registered to 15,000 counts per minute, 2 millisecond minimum pulse widths. 10 kOhm impedance.

H: High Impedance - 0-100 kHz non-simultaneous input operation standard. Separate add and subtract inputs or common data input together with up/down control line. Input impedance is 10 K ohm. Use with 715-1 shaft encoder.

V: AC Pulses - AC pulses 120 VAC. 50 counts per second. 75 K ohms impedance.

O: Optically Isolated - 1500 Hz maximum input

S: Up/Down Control - Use this with KEP encoder model 715-2. 5 VDC positive going pulses are fed into a single terminal. When held high, the up/down control line adds the incoming pulses to the total. When allowed to go low, the incoming pulses are subtracted from the total. 10 K ohm impedance.

Mounting: Panel mounted or "spring clip".

Termination: Printed circuit board edge connector supplied-standard

Zero Output: Logic level zero output provides 300 milliamps of switching power whenever the counter passes through or idles at zero This option is available in 4 digit models only.

Temperature: +32°F (0°C) to +130°F (+54°C)

HOOKUP

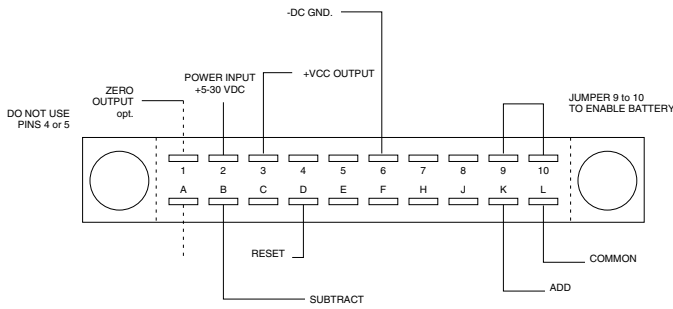

INPUT WIRING

SWITCH CLOSURE (Input H)

- ADD K TO 2
- SUB B TO 2
- RES D TO 2

DC PULSES (Input H)

- ADD K PLUS 6 GROUND
- SUB B PLUS 6 GROUND
- RES D PLUS 6 GROUND

OPTICALLY ISOLATED AND AC PULSES (Inputs SP & V)

- ADD K
- SUB B
- RES D
- COM L

MOUNTING

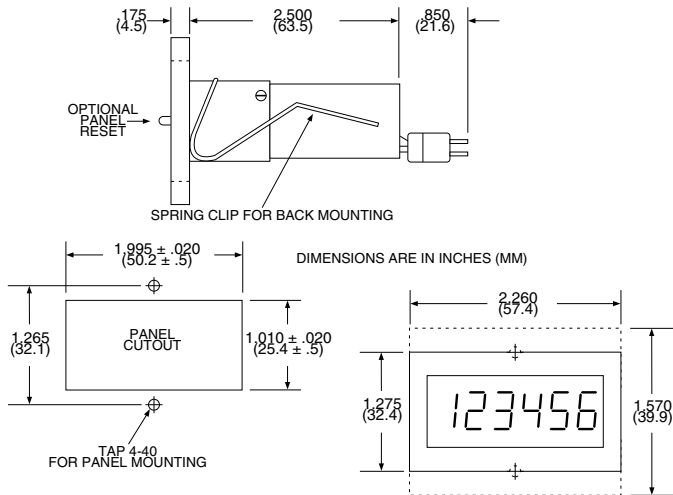

How To Order;

EX: K 0 8 2 3 SP(12) B 2 A Z.O. 50Hz

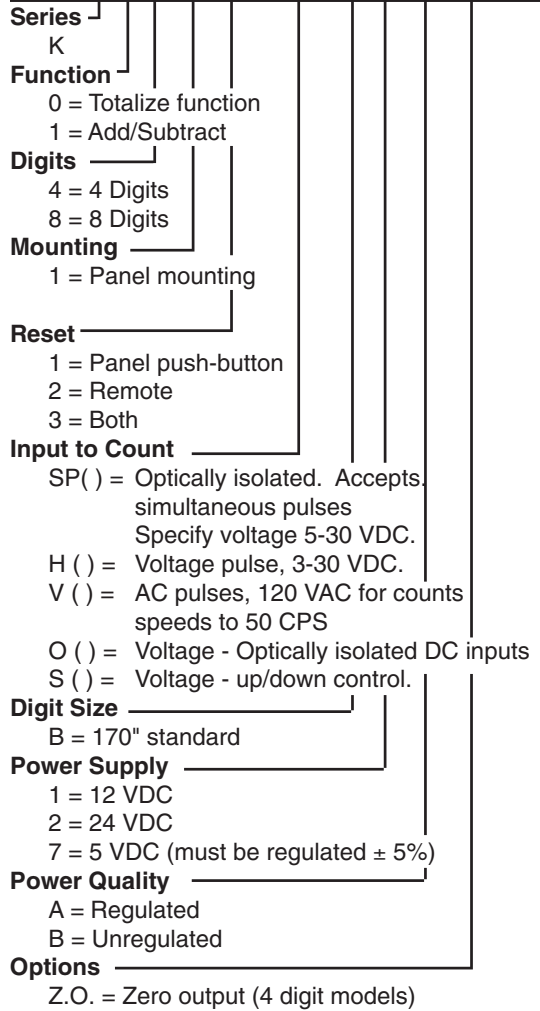

Count Speed (specify actual speed)

- 0-10KHz
- Over 10KHz
- Over 100KHz

Accessories

115-5 Power Supply

MC (Minicount)

High Speed, LED Electronic Counter

Features

- CSA Approved
- Counts Pulse Inputs Up To 10 kHz
- NEMA 4X / IP65 Front Panel
- 1/8 DIN Cutout
- Add & Subtract Capabilities



Applications:

This totalizing counter is perfect for high speed counting applications where a 6 digit total count is required.

Specifications:

Display: 6 digits, .55" high LED

Input Power:

- 110VAC ±15% or 12 to 15VDC
- 220VAC ±15% or 12 to 15VDC.
- 24VAC ±15% or 12 to 15VDC.

Current: Max. 250mA DC or 6.5 VA at rated AC voltage.

Sealing: Front panel sealed to NEMA 4X/IP65 specifications.

Excitation Voltage: (AC powered units only) + 12VDC @ 50mA unregulated -10% + 50%.

Memory: EEPROM Stores data for 10 years if power lost.

Input Types:

Standard: INPUT 3

This input is ideal for flowmeters that produce a DC pulse output. Also may be used with KEP 711 series or 715-1 encoders or PD & D series sensors. User can select high or low speed modes for debounce filtering. NOTE: For sinking driver inputs (NPN), use an external pull up resistor (2.2KΩ to 10kΩ) between pin 7 (+12VDC) and inputs used (pin 5 and/or 6).

Up/Down Control: INPUT 5

Count inputs on A, direction control input on B. When input B is "high" (4-30VDC), the count inputs on A will count up. If Input B is low (open or <1 VDC), the count inputs on A will count down. May be used with KEP 715-2 Encoder.

Quadrature: INPUT 9

Accepts pulses 90° out of phase for bidirectional counting. May be used with KEP 716 encoder.

NOTE: The unit will only show rate of one direction (when A precedes B).

NOTE: All inputs can be ordered with mag. input (30 mV) option (see "How To Order").

Reset: Rear terminal, 4-30 VDC negative edge triggered.

Approvals: CSA File# LR91109-7, CE Approved

Typical Application:

MC Series (MCHA3)

This unit is a dual input, bi-directional totalizer only. This unit does not have presets, outputs or scaling available. Each pulse received on input A or input B equals one count. The Minicount has separate up and down inputs. Pulses on pin 5 (input A) will count up (add); pulses on pin 6 (input B) will count down (subtract), even if the pulses occur simultaneously. Low and high count speed debounce filtering is factory set, output relays are not supplied with this unit. The MC series is perfect for applications where a low cost, bi-directional totalizer is needed.

TYPICAL WIRING

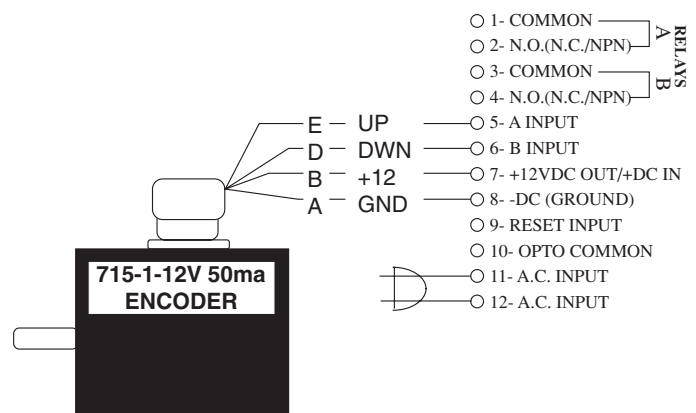

NOTE: Relay outputs are not supplied with MC series.

Dimensions:

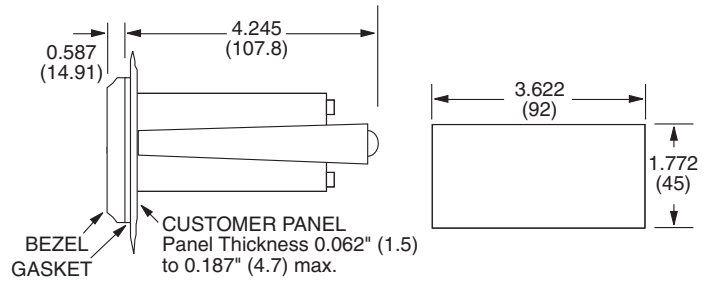
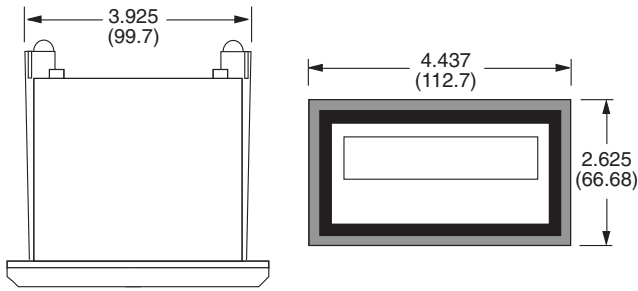

Open Collector Wiring:

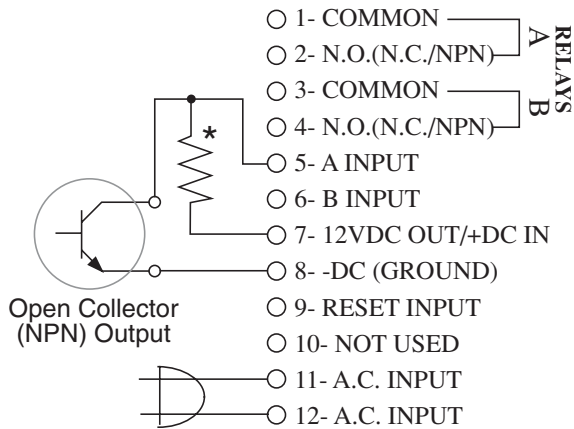

* Pull-up resistor required for open collector (NPN) outputs.
Use resistor values from 2.2kΩ to 10kΩ.

NOTE: Relay outputs are not supplied with MC series.

HOW TO ORDER

EXAMPLE:	MC	H	A	3	1
Series					
Input Speed					
Operating Voltage					
Count Input					
Options					

MC = Minicount Counter
L = Low speed input debounce filter 40Hz max.
H = High speed input (0 to 9.99 KHz)
A = 110 VAC ± 15% or 12 to 15 VDC
B = 220 VAC ± 15% or 12 to 15 VDC
C = 24 VAC ± 15% or 12 to 15 VDC
3 = Standard, 4-30 VDC simultaneous inputs.
3M = Mag. Input, Input A only, 30mV input (Input B, 4-30V)
3MB = Mag. Input, Inputs A & B, 30mV input
5 = 4-30 V pulses on Input A, 4-30 V Direction Control input on Input B.
5M = 30 mV pulses on Input A, 4-30 V Direction Control input on Input B
9 = Quadrature, accepts 4-30 V pulses
9MB = Quadrature, accepts 30 mV pulses (A & B)

Options
1= RS232 Communications
2= RS422 Communications

Accessories

Separate non keyboard panel order #34235
Separate keyboard panel - order #34237

CTR-544 Series

Multipurpose Device Counter, Timer or Ratemeter

Features

- Multipurpose device (programmable mode)
 - Display counter (adding and subtracting)
 - Position Monitor
 - rate meter
 - timer
- Display range –199 999 to 999 999
- Screw terminal connections
- Locking SET-Key for reset
- Option: Optocoupler output if f = 0, i.e. Operation indicator



Description:

The CTR-544 is a multipurpose device that can be programmed as a counter, position monitor, timer or ratemeter. It accepts DC pulse inputs up to 20kHz. It is a perfect solution for all high speed counting, timing and rate monitoring applications.

Specifications:

Supply voltage:	10 to 30 V DC, with reverse polarity protection 90 to 260 V AC 50/60 Hz mains hum suppression	Level of inputs:	DC-version Low: 0 to 0.2 x UB [V DC] High: 0.6 x UB ... 30 V DC AC-version Low: 0 to 4 V DC High: 12 to 30 V DC
Power consumption:	max. 2 W/6 VA	DC Output:	24 V DC \pm 15 %/100 mA (AC powered units only)
Display:	6-digit, red 7-segment LED's height 14 mm	Accuracy:	Ratemeter: <0,1 % Timer < 50ppm
Data backup:	EEPROM	Ambient temperature:	–10 to +50°C
Housing:	housing for control panel 96 x 48 mm acc. to DIN 43 700; RAL 7021, dark grey	Storage temperature:	–25 to +70°C
Polarity of Inputs:	programmable, npn or pnp for all inputs	EMC:	according to EC EMC directive 89/36/EWG
Input resistance:	appr. 10 k Ω	Interference emmissions:	EN 50081-2/EN 55 011 class B
Input frequency:	20 kHz, can be damped to 30 Hz (11 kHz max. for position display)	Interference resistance:	EN 6100-6-2
Reset time:	5 ms	Protection:	NEMA4/IP65 (front panel)
Timer resolution:	up to 0.001 s	Weight: appr.	150 g

Wiring Connections

Rear View

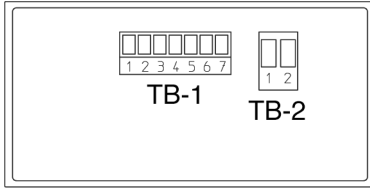

Dimensions

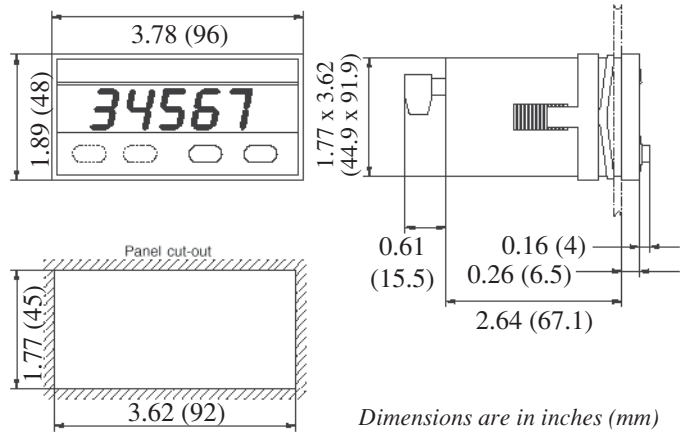

TB-1 Measurement Inputs

Pin	AC-version	DC-version
1	Optocoupler-output Emitter	
2	Optocoupler-output Collector	
3	SET	
4	INP B	
5	INP A	
6	GNDout	n.c.
7	+24 Vout	n.c.

TB-2 Supply Voltage and Outputs

Pin	AC-version	DC-version
1	90 ... 260 V AC	0 V DC (GND)
2	90 ... 260 V AC	10 ... 30 V DC

Order Code

Example: CTR544.01 0 00

Series: _____
 CTR-544 = Multipurpose Device
 Counter, Timer or Ratemeter

Operating Voltage: _____
 0 = 90 to 260 VAC
 3 = 10 to 30 VDC

Options:
 00= None
 01 = Optocoupler output

SUPER-KAL

Features

- 6 Digit Display with 9.6mm High Characters
- Supertwist Display Viewable From Any Angle
- Meets NEMA 4 and IP65 Ratings
- EEPROM Memory
- 50 kHz High Speed Input
- 30 Hz Low Speed Input for Contact Closures

DESCRIPTION

This unit monitors both rate and totalizing count simultaneously. While the display is indicating units per minute (period mode) a “background” totalizer keeps count of events or items. The ratemeter function can operate in either Period or Gated mode. The display indicates the mode and whether the multiplying or dividing prescaler is in use. (Totalizer is not available when the ratemeter is in Gated mode).

A push-button on the front panel can toggle the display between rate and count readings and is also used to reset the count (by holding it pressed for 3 seconds). Mode selection, prescaling and decimal point positioning are all configured in programming which is carried out using the two push-buttons on the front panel.

The operating voltage can be selected by moving a jumper on the back of the unit.

SPECIFICATIONS

Display

6-Digit Supertwist, 9.6mm characters. Locatable decimal point to 0, 1, 2 or 3 places of decimals. Leading zero blanking.

Annunciators

PROGRAM (mode), PERIOD or GATED (modes), TOTALIZER, MULTIPLIER or DIVIDER (prescalers).

Ranges

Totalizer: 0-999999 with roll over to 0.

Period mode Measurement: 3-19,999 PPM (1/20Hz-333.3Hz).

Gated mode Measurement: 0-50kHz.

Gated Mode Timebase: 0.01-9.999S adjustable in 1mS intervals.

Accuracy

Both Gated and Period modes: ± 1 least significant digit or 0.18% whichever is the greater.

Prescalers

Period Mode Divider: 1-9999

Totalizer Divider: 1-9999

Totalizer Multiplier: 0.01-9.999 in 0.001 increments

Program and Data Security

Program disable input allows authorized personnel only to change program. Internal EEPROM retains program indefinitely after power loss.

Combined Totalizer and Ratemeter with Scaling



Approvals: CE Approved

Factory Default Settings

Unit adopts Period mode on power up
Annunciators: PERIOD annunciator only

Period Mode Divider Prescaler: 1

Gated Mode Timebase: 1 second

Totalizer Divider Prescaler: 1

Decimal places: 0

Low Speed (Contact closure) Input

30Hz maximum frequency. 0.7V threshold, 15mS minimum closure time. Negative edge triggered.

High Speed (Electronic) Input

50kHz maximum frequency. Logic 0: <0.7V DC, logic 1: >2.4V DC. TTL/CMOS compatible. Maximum input 18V. 10 μ S minimum pulse length. Negative edge triggered.

Dimensions

Front 72mm x 36 mm. Depth 32mm (excl. connector)

Panel Cutout

69mm x 33 mm \pm 0.2mm.

Power Supply

Measurement function: 10-30VDC 8mA

With Backlight 12V or 24VDC @ 100mA or 50mA.

Operating temperature

-10°C to +60°C

Storage temperature

-10°C to +70°C

Housing

Black die-cast aluminium

Mounting

Panel mounting using supplied clip

Sealing IP65/NEMA4 using gasket supplied

FUNCTIONS and MODES

GATED MODE (Frequency) utilizes a variable time base and counts the number of pulses occurring within the time frame (number of pulses through the “gate”).

PERIOD MODE (RPM) derives its output by computing the reciprocal of the time period measurement between successive pulses.

TOTALIZER function. The unit operates as a totalizing up counter when the Ratemeter is in Period Mode.

Mode selection prescaling and decimal point positioning are carried out in programming mode (see next page).

MODE APPLICATIONS

Period mode is suitable for relatively slow events such as items passing on a conveyor belt. An application which uses the dividing prescaler is measurement of shaft rotation by counting the passing teeth on a gear. If the gear wheel has 64 teeth, set the Period mode divider prescaler to 64 and the unit displays rate in revolution/min.

Gated mode is for high speed electronic inputs and will measure frequency up to 50kHz.

NOTE: Positioning of the decimal point allows the user to display Period or Gated measurements in chosen engineering units. A 100Hz frequency will show as 100 when there is no decimal point but as 1.00 if two places of decimals are selected.

PROGRAMMING

To enter programming press the recessed Program button on the front panel using a ball point pen or similar. The PROG annunciator appears on the display. Only the two front panel buttons are used for programming.

The Reset button changes the parameter (number of decimal places, increments the displayed digit, toggles between available options etc.).

The Program button accepts the currently displayed value or function and continues to the next step in the sequence.

The parameters which appear on the display during programming are those which were set up at the preceding programming session. You can use this facility to review the settings by entering programming and going through the sequence again.

If a time base or multiplier prescaler less than 0.01 is entered, the unit will default to 0.01 on exit from the programming mode. The programming sequence is shown in the illustration.

When you press the Program button to accept the last parameter in the programming sequence, the unit exits from the program mode and adopts the mode which you selected at step 1.

OPERATING

To toggle the display between the totalizer count and the Period mode rate measurement, press the Reset button on the front panel. (Totalizer is not operating in Gated Mode).

To Reset the totalizer count to zero press Reset and hold it for 3 seconds.

The Reset function can be disabled in the programming sequence.

ANNUNCIATORS

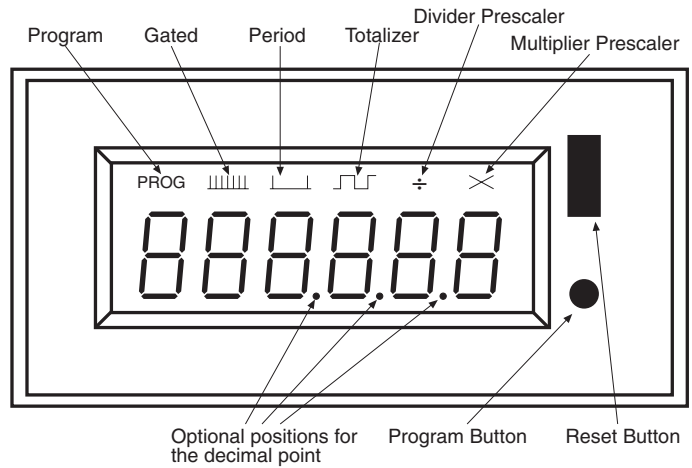

DIMENSIONS

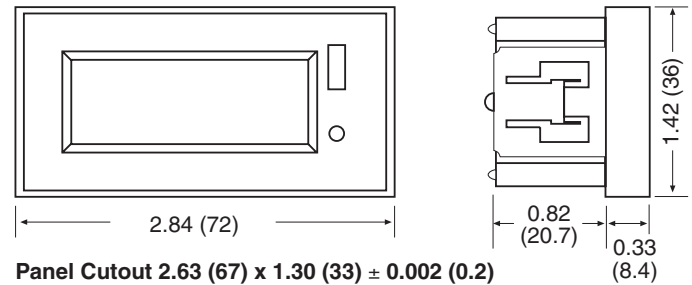

CONNECTIONS

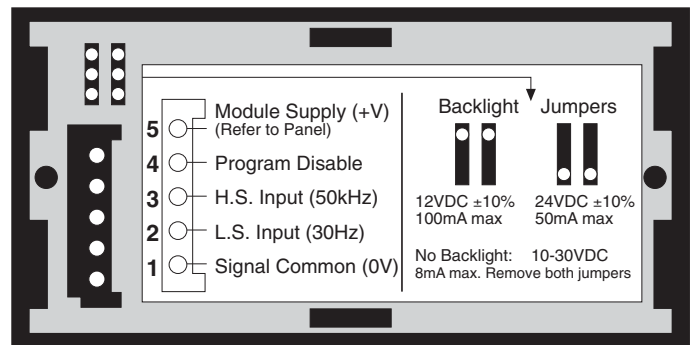

HOW TO ORDER:

- SKAL1 Standard
- SKAL2 With Backlight

520K-530K

Pulse Counters, Position Displays, Rate Meters, Time Meters & Combinations

COUNTERS

New Family: Your choice for your application!

Features

- LED display with very high luminosity
- 0.315" (8mm) digit height
- 6 digit display
- DIN housing, 1.88"x.944" (48x24mm)
- Easy programming with only 2 buttons
- Connection with screw terminal
- IP65 NEMA 4X (front)
- Input pulse-shape variable (Schmitt Trigger characteristics)

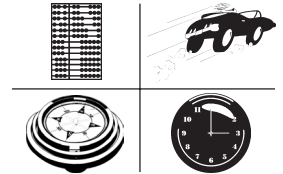
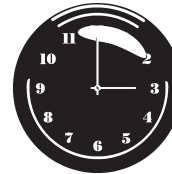
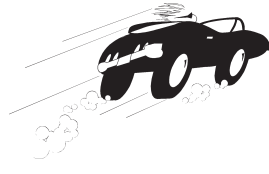
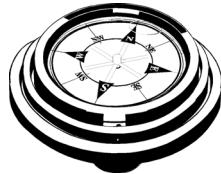
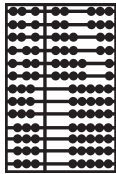

520K

Simple Display Counter

- Display range 0..999999 with leading zero blanking
- Overflow condition will be indicated by displaying the count value without leading zero blanking
- Count frequency up to 10kHz (can be damped to 30Hz in setup)
- SET-key resets the counter to zero (can be disabled in setup)
- 1 count input
- 1 reset input

Order #: 520K.2

521K

Totalizer and Position indicator

- Display range -199999..0..999999 with leading zero blanking
- Overflow condition will be indicated by 1Hz flashing of display
- Count frequency up to 10kHz (can be damped to 30Hz in setup)
- SET-key resets the counter to zero (or selected preset number)
- 2 count inputs
- 1 reset input
- Multiplying factor (0.00001...99.9999)
- Option: optocoupler output if count value ≤ 0
- Counting with direction input, differential counting, counting with phase discriminator (also with pulse doubling)

Order #: 521K.1 w/optocoupler
521K.2 w/out optocoupler

522K

Frequency meter and Tachometer

- Display range 0..999999 with leading zero blanking
- Indicates rate per sec or min (1/Tau) to 0.1% accuracy
- Overflow condition will be indicated by 1Hz flashing of display
- Input frequency up to 10kHz (can be damped to 30Hz in setup)
- 1 count input
- Operating principle: period duration measurement (average value at higher frequencies)
- Option: optocoupler output if frequency $f=0$ (e.g. no operation indicator)
- Multiplying factor (0.00001...99.9999)

Order #: 522K.1w/optocoupler
522K.2 w/out optocoupler

523K

Time meter

- Display range 0..999999 with leading zero blanking to 0.03% accuracy
- Lowest digit's decimal point flashes when timing
- Timing in s, min, h or h.min.s (programmable) Timing resolution x1, .1, .01, .001, fixed by selected decimal point
- SET-key resets the counter to zero
- Gate, start and stop via 2 inputs (programmable)
- 1 reset input
- Operation mode: Precise timing from hours to 1/1000 sec
- Option: optocoupler output (e.g. Timing indicator, 0.5 sec On/Off)

Order #: 523K.1 w/optocoupler
523K.2 w/out optocoupler

524K

Multipurpose device

- 521K-523K in just one device
- Operation mode can be programmed

Order #: 524K.1 w/optocoupler
524K.2 w/out optocoupler

NOTE: E200 Outdoor Enclosure and N7 Explosion Proof Housing available for all Models (see accessories section)

525K**Adding Counter and Tachometer**

- Display range 0..999999 with leading zero blanking
- Overflow condition will be indicated by 1 Hz flashing of rate value and leading zeros of totalizer
- Count frequency up to 10kHz
- Indicates rate / sec or min (1/Tau)
- SET-key resets the counter to zero (can be disabled in the setup)
- 2. key to switches rate / total display
- 1 count input
- 1 reset input
- Separate multiplying factors counter / tachometer (0.00001...99.9999)
- Operating mode: Rate meter: 1/Tau (average value at higher frequencies)

Order #: 525K.2

526K**2 Display Counters**

- Display range 0..999999 with leading zero blanking
- Overflow indicated by the leading zeros
- Count frequency up to 10kHz
- SET-key resets the counter to zero (can be disabled in setup for each counter separately)
- Push-button for switching between counter 1 and counter 2
- 1 count input
- 1 reset input (programmable for each counter separately in setup)
- One multiplying factor (0.00001...99.9999)

Order #: 526K.2

527K**Display Counter and Time meter**

- Display range 0..999999 with leading zero blanking (Overflow shows leading zeros)
- Lowest digit's decimal flashes when timing
- Adding counter: Decimal point only optical function
- Hour meter: Timing in s, min, h or h.min.s (programmable) Decimal point fixes the resolution
- SET-key resets the counter to zero (can be separately disabled in the setup for each channel)
- Push-button switches adding counter / time meter
- Count frequency up to 10kHz
- 1 count input
- Gate, start and stop via 1 input (programmable)
- 1 reset input (can be disabled in setup)
- Multiplying factor (0.00001...99.9999)

Order #: 527K.2

528K**2 Time meters**

- Display range 0..999999 with leading zero blanking
- Active timing will be indicated by flashing the lowest digit's decimal point (one control)
- Timing in s, min, h or h.min.s (programmable) Decimal point fixes the resolution (ex: 1, 0.1, 0.01, 0.001)
- SET-key resets the counter to zero (can be disabled in the setup)
- Push-button for switching between time meter 1 and 2
- Gate, start and stop via 2 inputs (programmable)
- 1 reset input (programmable for each timer separately in setup)

Order #: 528K.2

529K/530K**Analog Displays**

- Display range -19999..0..99999 with leading zero blanking
- Resolution 14 bit
- 5 digit display 6 digit total display (530K)
- 4 different resolutions (0..20mA; 4..20mA; 0..10V or 2..10V)
- Scaling factor for displayed value
- Automatic storage of maximum and minimum value (can be disabled in setup)
- Input to activate storing of displayed value

Order #:

529K.2 = Rate Display Only

530K.2 = Rate and Total Display

NOTE: E200 Outdoor Enclosure and N7 Explosion Proof Housing available for all Models (see accessories section)

Electrical characteristics:

- Supply Voltage: 10 to 30 VDC
- Data retention: EEPROM (1 million cycles or 10 years)
- Noise immunity acc. to EN 50081-2; EN55011 class B; EN 50082-2
- Ambient temperature: 14°F to 122°F (-10°C to +50°C)
- Input sensitivity: Low: 0 to 1 VDC High: 4 to 30 VDC
- Input resistance: 10 k ohm
- Polarity of inputs: programmable for all inputs in common
- Optocoupler: Max 30VDC, 10 mA, 1V drop @ 10 mA

Panel Cutout: 0.876" x 1.78" (22.3 x 45.2mm)
or 0.99" x 1.97" (25 x 50mm) with adaptor provided

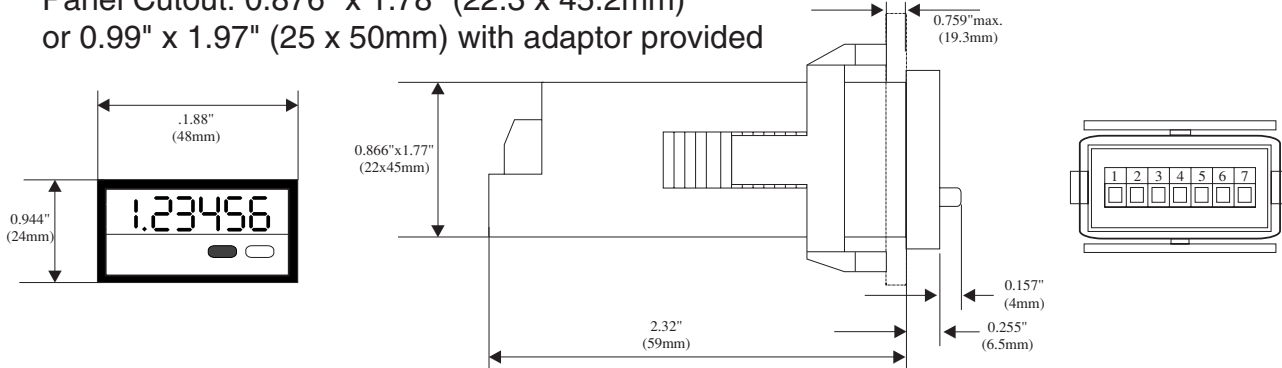

BVA

Electro-Mechanical Preset Counters

Features

- 5 Large Digits
- Visible Setpoint Number
- Counts Up With Output at Preset
- 5 Amp, Form C Switch
- Many Voltages Available
- Rugged Case (50 x 50 mm)

Applications:

For counting and controlling industrial processes and production quantities. Offers high noise immunity while displaying number of items and preset number even if power is lost.

Description:

The BVA is a 5 digit preset counter loaded with features never before offered. The BVA has 2 registers. One shows the set point continuously. The other totalizes the incoming pulses. At coincidence, a 5 Amp form C relay transfers. The totalizer meanwhile continues adding any incoming pulses to the total providing an accurate tally of overrun. One hand sets the BVA. Simply push the conveniently located set buttons and change the preset register. All standard voltages are available in a 50 x 50 mm rugged plastic case.

COUNT INPUTS Counting Mechanism

Voltage	Max. cps	Min. pulse duration	Min. pulse interval	Pulse ratio	On time	Power consmp.
DC	10/s	60 ms	40 ms	3:2	100%	1.6W
	25/s	24ms	16ms	3:2	100%	3W
	40/s	15ms	10ms	3:2	60%	5.5W
AC	10/s	50.0ms	50.0ms	1:1	100%	2.2VA
	18/s	27.7ms	27.7ms	1:1	100%	3.0VA



PRESET COUNTERS

Specifications:

Digits: 5 digits, 0.195" high.

Preset Register: yellow numbers on black.

Totalizing Register: white numbers on black.

Termination: Push on connectors (supplied). Wire leads optional.

Voltages:

6,12, 24, 48, 110DC $\pm 10\%$

24, 48, 110, 220AC. $\pm 15\%$

Switching: Form C contacts transfer after the total count reaches the final half step of the preset number. Switch remains transferred until reset. Totalizing may continue without effect.

AC Load Max: 250VAC = 5 Amps

DC Load Max: 24VDC = 2 Amps

60VDC = .7 Amps

110VDC = .4 Amps

220VDC = .2 Amps

Arc suppression recommended for inductive loads.

Temperature: - 10 ° to 60 ° (+14 °F to 140°F) standard.

Wiring Diagram:

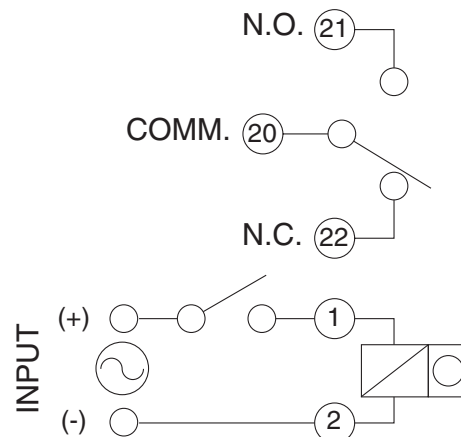

0 Mounting Style:

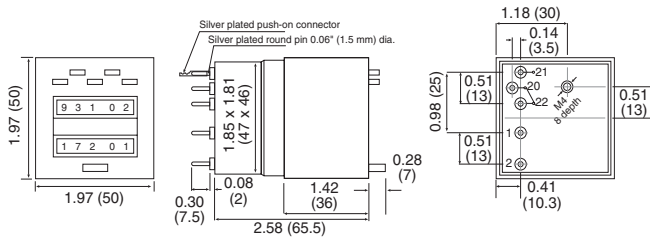

1 Mounting Style:

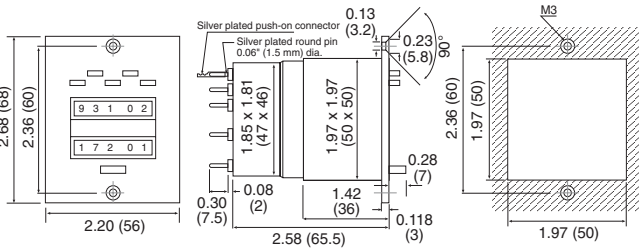

2 Mounting Style:

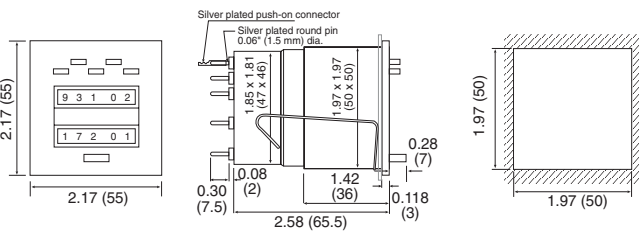

3 Mounting Style:

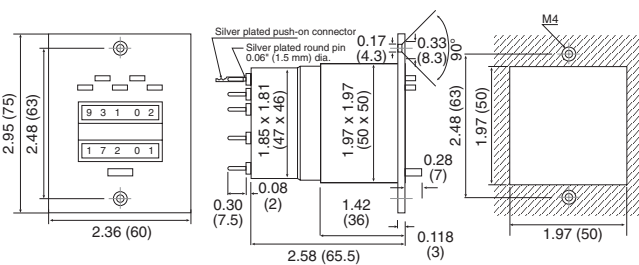

F2B Option:

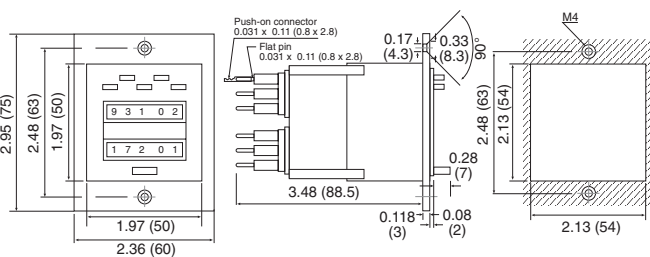

F2DV Option:

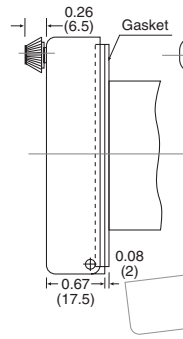

F2DVS Option:

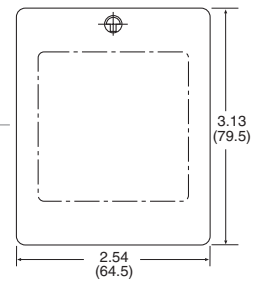

K2 Option:

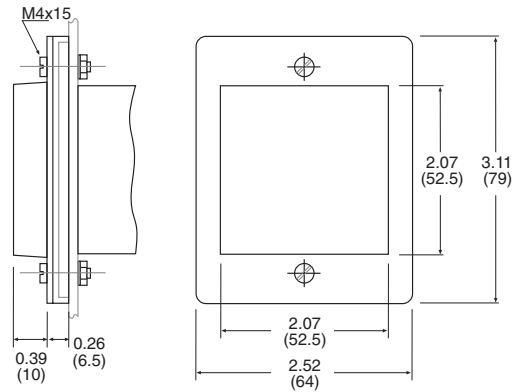

How To Order:

EXAMPLE: BVA15 1 1 24VDC 25CPS

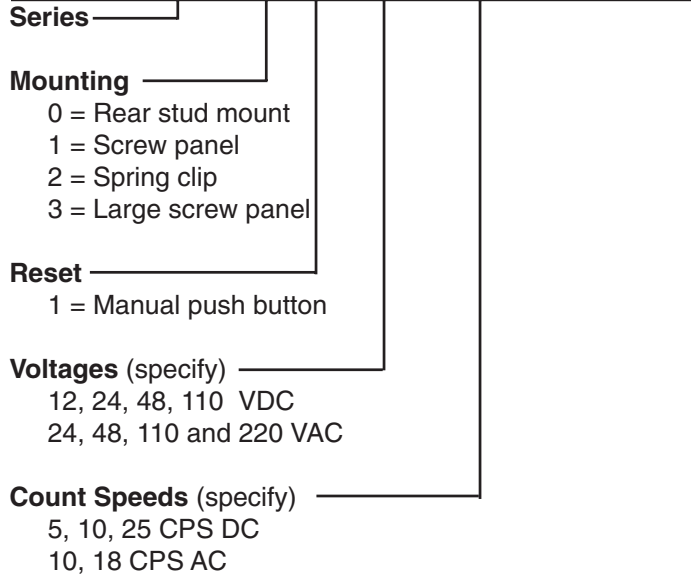

Available Options (add to end of part number)

- K2 - Silicon cover
- F2 - Frame w/ Socket Box
- F2DVS - Frame w/ locking cover & Socket Box
- F2DV- Frame w/ knob cover & Socket Box
- US - Key reset
- DVS -Locking cover without Frame
- DV - Knob cover without Frame
- N7 - Explosion proof housing (see accessories section)
- 50 CPS (DC only)

CTF5

LED Preset Add/Subtr. Counter, Timer, Frequency Meter

Features

- 5 Digit Counter, Timer or Frequency Meter
- Input Scaling (0.001 to 9.999) Multiplier
- Bright LED Display .295" (7.5 mm) High
- Count & Preset Range of -19999 to 99999
- Add or Subtract Count Control
- AC or DC Operation
- 10 Year Data Memory
- 24VDC to Power Peripherals

Applications:

Preset batch counting, length measuring, simple positioning, time control, speed control, rate control.

Description:

The CTF5 is a LED preset counter, timer or frequency meter. The following features are programmable: operating mode (output at 0 or preset, with or without autoreset), decimal point, polarity of input (NPN or PNP), output signal latched or timed, gate time (frequency meter), time resolution (Hrs., Min., Sec; timer)

Inputs:

Input A, Input B: Count inputs. Max. count speed is 30 Hz or 10 kHz separately selectable for both inputs.

Gate: Voltage level gate input; Counter & Freq. Mode - inhibits counts when activated.

Timer Mode - Starts timing when activated.

Reset: Edge triggered reset input; it is connected in parallel with the front reset key and resets the counter to 0 (add) or preset (sub).

Latch: Voltage level input for display hold; when activated, the display "freezes" the current count value while counting continues in the background. The display updates when this input is de-activated.

Key: Voltage level keyboard lock input; when activated, all front keys are disabled.

Selection of Basic Function:

1. Impulse Counter
2. Frequency Meter
3. Timer

IMPULSE COUNTER

Decimal Point: 0 to 3 (for display only)

Scaling Multiplier: 0.001 to 9.999

Output Signal: Timed signal (0.01 to 99.98 sec) or Latched signal (00.0) selectable. (99.99 setting gives inverted latched output- output activates at power on and deactivates when preset is reached)



Polarity: Negative (NPN) or positive (PNP) polarity of inputs. Polarity selected applies to all inputs.

Input Modes:

E1: One count input (Input A) and one count direction input (Input B). If direction input is open, the counter adds, if it is activated the counter subtracts.

E2: Separate inputs, one up input (Input A) & one down input (Input B).

E3: Quadrature input, accepts two pulse inputs 90° ($\pm 15\%$) out of phase for direction control.

E4: Quadrature (x2) input, counts leading and falling edge of input A.

FREQUENCY METER

Gate: Gate time selectable from (0.01 to 99.99 sec) All pulses counted during this time will be displayed for one gate time (i.e. gate time of 1 will display Hz).

Decimal Point: 0 to 3 (for display only)

Polarity: Negative (NPN) or positive (PNP) polarity of inputs. Polarity selected applies to all inputs.

Input Modes: As described under Impulse Counter.

Scaling Multiplier: 0.001 to 9.999

Output Signal: Output activates for selected time (0.01 to 99.98 sec) when display reaches or exceeds preset value; If output time setting is 00.00, the output will activate when display reaches or exceeds the preset and deactivate when below preset. (99.99 output setting gives inverted latched output- output activates at power on and deactivates when preset is reached)

TIMER

Time Resolutions: Times in sec., min. or hrs. with resolution in 0.001, 0.01, 0.1 or 1.0 (depending on decimal).

Polarity: Negative (NPN) or positive (PNP) polarity of inputs. Polarity selected applies to all inputs. (Gate controls timing)

Output Signal: Timed signal (0.01 to 99.98 sec) or Latched signal (00.0) selectable. (99.99 output setting gives run time control latched output- output activates only while timer is running and deactivates when preset is reached.)

Specifications:

Operating Voltage: (All voltages ± 10%)

- A: 115VAC 50/60Hz
- B: 220VAC 50/60Hz
- C: 11 to 30 VDC
- D: 24VAC 50/60Hz

Power Consumption:

- DC: 100 mA max.
- AC: 4 VA max.

Display: 7 segment LED 5 digit 0.295" (7.5 mm) high.

Count Speed: 30 Hz or 10 kHz (7.5 kHz for input mode E4 "Quad x2"); 1 kHz for autoreset without count loss (600 Hz for input mode E4 "Quad x2") separately dip-switch selectable for both inputs.

Min. Pulse width for Control Inputs: 5 msec

Input Impedance: Approx. 10 kOhm

Input Sensitivity:

- Logic "0": 0 to 1 VDC
- Logic "1": 4 to 30 VDC

Control Output:

Relay: SPDT 3A relay, 250 VAC / 300 VDC max. Switching current for DC min. 30 mA

Opto-Isolated Output: Open collector and emitter.

Max. Voltage: 30 VDC

Max. Current (ON state): 5 mA @ 0.4 V drop; 15mA @ 2.0 V drop

Response Time:

- Relay: Approx. 6 msec
- Opto-Isolated: Approx. 1 msec

Output Power (AC powered units): 24 VDC -40% / +15%, 80mA, unregulated

Memory: min. 10 years or 10⁶ memory cycles

Operating Temperature: 32° F to + 122° F (0° C to +50° C)

Noise Immunity: EN 55011 class B and prEN 50082-2

Storage Temperature: - 13° F to + 158° F (-25° C to +70° C)

Weight: Approximately 9 oz. (240g) (AC version with relay)

Protection: NEMA 4 /IP65 (front)

Approvals: UL File# E167238, CE Pending

Terminal Designations:

AC Supply Wiring

TB-1		TB-2	
Term. #	Description	Term #	Designation
1	+24 VDC Output	1	INPUT A
2	0 VDC (Ground)	2	INPUT B
3	Relay - C (Opto Emitter)	3	GATE INPUT
4	Relay - NO	4	RESET
5	Relay - NC (Opto Collector)	5	LATCH
6	AC Input	6	KEY
7	AC Input		

DC Supply Wiring

TB-1		TB-2	
Term. #	Description	Term #	Designation
1	No Connection	1	INPUT A
2	No Connection	2	INPUT B
3	Relay - C (Opto Emitter)	3	GATE INPUT
4	Relay - NO	4	RESET
5	Relay - NC (Opto Collector)	5	LATCH
6	(+) 11-30 VDC Supply	6	KEY
7	(-) 0VDC Supply (Ground)		

Dimensions:

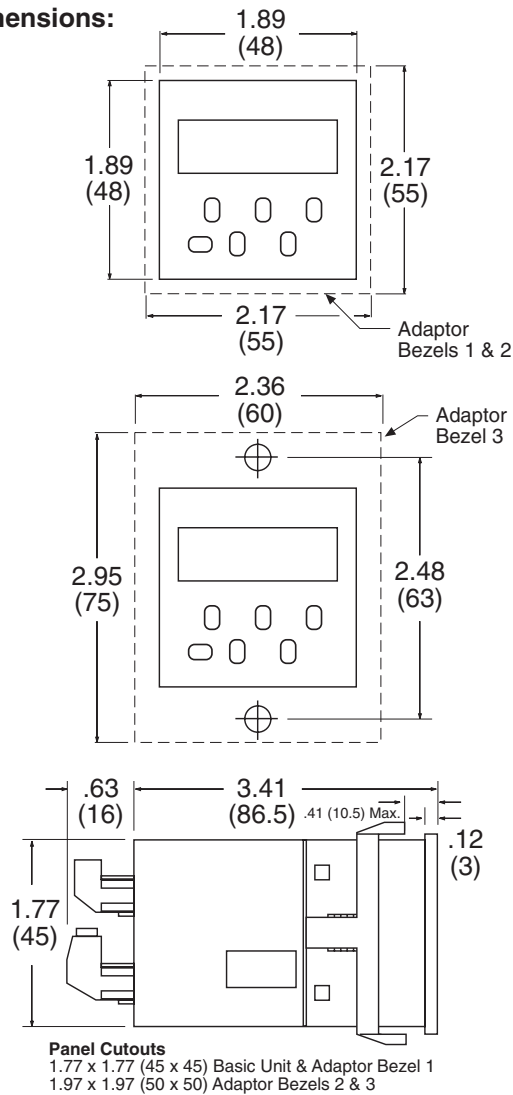

Adaptor Bezels 1, 2 & 3 Supplied

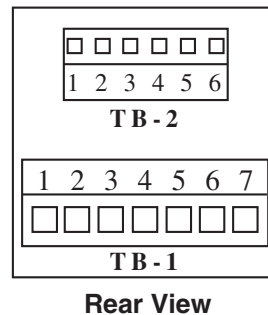

How To Order:

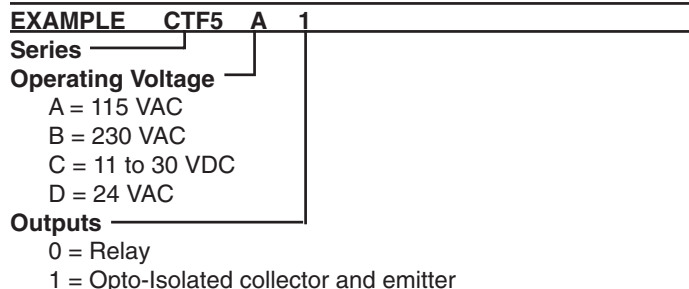

CTF16 / 17

6 Digit LED Preset Add/Subtr. Counter, Timer, Frequency Meter

Features

- 6-Digit Preset Counter with Sign & Scale Factor
- Available with One or Two Presets
- Programmable as a Pulse Counter, Frequency Meter or an Operating Time Counter
- Wide-Range Power Supply 90-250 VAC
- Counting Speed up to 20 kHz
- Extremely Simple Use and Programming by Means of Only 4 Keys
- RS-232, RS-422 or RS-485 Serial Interface

Applications:

Preset batch counting, length measuring, simple positioning, time control, speed control, rate control.

Description:

The CTF16/17 is a LED preset counter, timer or frequency meter. The following features are programmable:

- Operating mode (counter, timer or ratemeter)
- Polarity of the inputs (NPN or PNP)
- Scale factor
- Output signals :continuous or pulse signal
- Frequency meter display mode : 1/s or 1/min
- Resolution in s, min, h or h:min:s
- Start and Stop for the time counter/hours meter

Inputs

2 counting inputs

The maximum frequency is 20 kHz (12 kHz for Quad Input); 30 Hz debounce setting for contact closure inputs.

GATE

Inhibits count, controls timer

RESET

Edge triggered, Resets the counter to zero when counting up, and sets it to the preselected value when counting down. (Same as front reset button)

KEY

The keys are locked as long as this input is ON. The P preselection display key remains active.

Outputs

1 or 2 potential-free relay or optocoupler outputs as ordered.

Programming

The CTF16/17 are programmed by means of the 4 front keys. The display prompts simple and intuitive programming.

Programmable are:

Input polarity

Positive (PNP) or negative (NPN). The selection is valid for all inputs.



Pulse or time counting modes

- Adding with counting start at 0
- Subtracting with set to preset (CTF16) (preset 2 for CTF17)
- Adding with automatic reset
- Subtracting with automatic set to preset (preset 2 for CTF17)

Input types in pulse counter mode

Cnt. Dir	1 counting input; 1 counting direction input
uP. Dn	1 adding input; 1 subtracting input
quad	Phase discriminator to connect pulse sources with 2 signals shifted by 90°
quad2	Phase discriminator with double pulse processing, to connect pulse sources with 2 signals shifted by 90°

Decimal places

Select one, two or three decimal places.

Scale factor

Multiplying scale factor between 0,0001 and 99,9999.

Output signal

Each output can be selected as an opening signal, a closing signal or as a positive or negative pulse signal.

Time counter

Select time base of h, min, s or h:min:s. Set the resolution by selecting up to 3 decimal places.

Frequency meter/Tachometer/Speed indicator

Display in 1/min or 1/s with automatic conversion.

Interfaces

The devices can be fitted with the optional RS 232, RS 422 or RS 485 interfaces. These interfaces can be used to program the devices as well as for remote reading. They are simply controlled by ESC sequences.

Explosion Proof Housing Option

- All functions corresponding to type 717 with relay output
- Sturdy, hard-coated aluminium housing with insert moulded connection cables (2 x 3 m)
- Protection type: EEx d IIC T6
- PTB approval no.: Ex-96. D. 1024

Specifications

Display: 6 digits, 7 segment LED's, height 8 mm
 Presets: 2 preset values for model CTF17
 1 preset value for model CTF16
 Counting inputs: 2 counting inputs, 4 types of programmable inputs
 Polarity of the inputs: programmable, common to all inputs
 Input resistance: Approximately 10 kΩ
 Maximum counting frequency: 20 kHz, can be set to 30 Hz for contact closure inputs
 Minimum pulse duration for control inputs: 5 ms
 Input switching level: Log "0": 0 to 1V
 Log "1": 4 to 30V
 Pulse shape: any shape (Schmitt-trigger)
 Output : Programmable output state (energised (N.C.) or de-energised (N.O.))
NOTE: When high to low output selected (), the output is activated when unit is powered and display is below preset. This may appear reversed.
 Relay: CTF16: 1 SPDT
 CTF17: 1 SPDT; 1 SPST
 Switching power: 250 V @ 3A Max
 DC Max 50 Watts, Min 30mA
 Optocoupler: Off: 30 VDC max
 On: 2V @ 15mA, 0.4V @ 5mA
 Supply voltage: 90 to 250 VAC, 5VA max, or 10 to 30 VDC, 1W max
 Supply voltage output for external sensors: 24 VDC, 100mA (AC versions)
 Accuracy of speed indicator mode: < 0,1 %
 Accuracy of timer mode: ± 50 ppm
 Output response time: Relay: approximately 7 ms
 Optocoupler: approximately 2 ms
 at least 10 years or 10⁶ recording cycles
 Data storage:
 Interference immunity: EN 61000-3-3, EN 55011 class B and EN 50082-2 with shielded control lines
 Operating temp.: -10°C..+50°C
 Storage temp.: -25°C..+70°C
 Weight: approximately 200 g. (AC version & relay)
 Protection: NEMA4 (IP 65) Front Panel

TERMINAL X1

Terminal No.	AC Version	DC Version
1	No Connection; Relay Com (C) (emitter)*	
2	No Connection; Relay N.O. (collector)*	
3	Relay Output Common (C) † (Emitter for optocoupler output version)	
4	Relay Output N.O. †	
5	Relay Output N.C. † (Collector for optocoupler output version)	
6	90 to 250 VAC Supply Voltage	10 to 30 VDC Supply Voltage
7	90 to 250 VAC Supply Voltage	0 VDC (ground) Supply Voltage

* CTF17 Preset #1
 † CTF17 Preset #2

TERMINAL X2

Terminal No.	AC Version	DC Version
1	+ 24VDC Out	No Connection
2	0 VDC (ground)	No Connection
3	Input A	
4	Input B	
5	Reset	
6	Gate	
7	Key	

Dimensions:

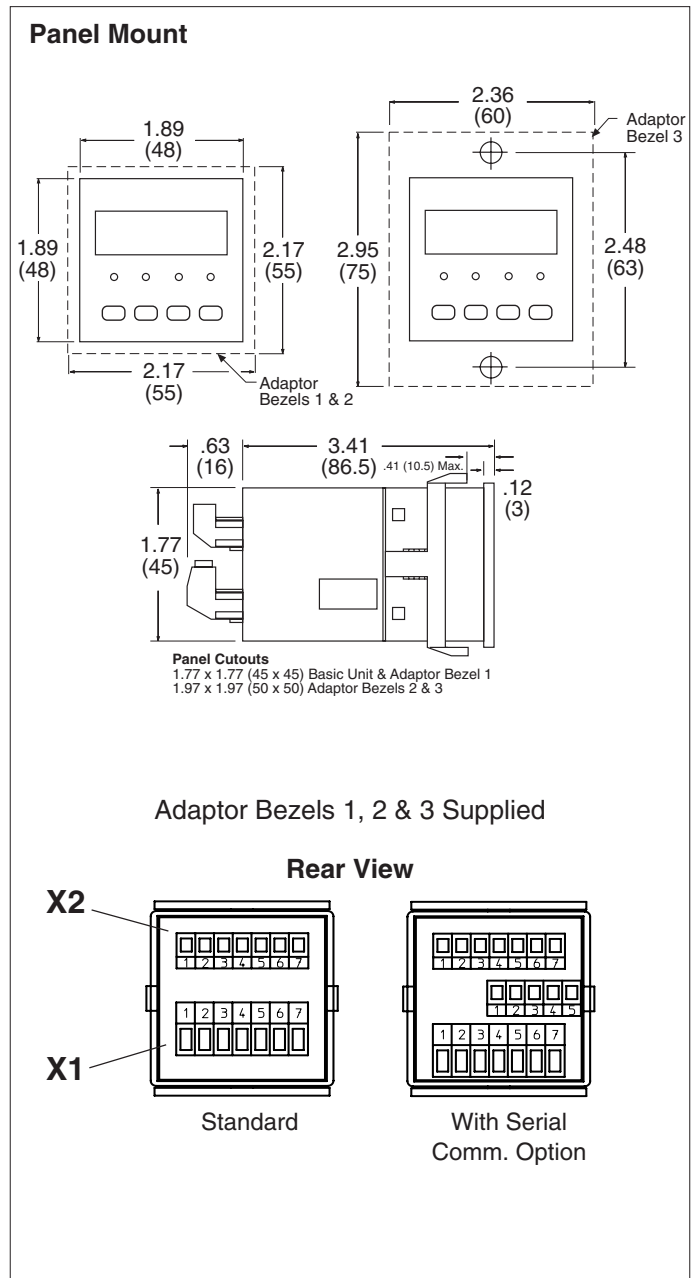

How To Order:

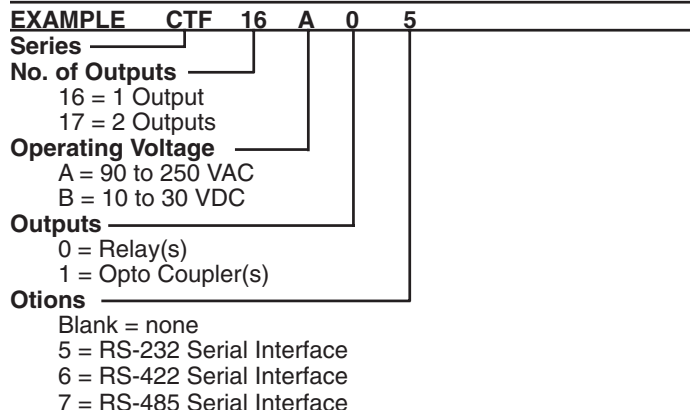

KEPTROL

Counter, Timer or Ratemeter

Features

- Counter, Timer or Ratemeter
- Counts Up To 100 kHz
- 8 Digit Display
- Input Scaling
- Batch Counter
- DC Output to Power Peripherals Sensors
- NEMA 4X / IP65 Sealed Front Panel

Applications:

Metering, Rate Monitoring, Cut to Length, Coil Winding, Batch control, all in one programmable unit.

Description:

Featuring 8 digits of bright .55 inch alpha-numeric display, the KEPTrol can accept up to 100,000 pulses per second of digital count or rate data, and time in keyboard selected ranges of 1/10,000 of a second to hours. The unit can multiply the input from 0.0001 to 99.9999 to easily understood units of measurement and give two control outputs at separate set points.

Selection of counter, timer or rate meter function as well as input scaling, timer frequency, preset levels, output timing and special security number are entered on the sealed front keypad by following instructions written on the display.

The unit operates from either 110 VAC /12 to 27 VDC or optional 220 VAC /12 to 27 VDC. If AC power is used, two built-in regulated 12 VDC ~100 mA power supplies are offered. They can be connected to provide + 12 VDC and - 12 VDC or + 24 VDC to drive external devices. CMOS logic is used to provide high noise immunity and low power consumption with EEPROM to hold data a minimum of 10 years if power is interrupted.

Integrating the KEPTrol with computers or programmable controllers is made easy by optional RS232 or RS422 interface. Up to 15 units can be addressed separately to set control points or access data through the I/O ports.

Specifications:

Display: 8 digit .55" high, 15 segment red orange LED.

Input Power: A: 110 VAC \pm 15% or 12 to 27 VDC. B: 220 VAC \pm 15% or 12 to 27 VDC.

Current: Max. 280 mA DC or 5.3 VA at rated AC voltage.

Output Power: (on AC powered units only): + 12 VDC @100 mA. Separate isolated 12 VDC @100 mA to allow \pm 12VDC or +24 VDC, regulated \pm 5% worst case.

Memory: EEPROM stores all program and count data for minimum of 10 years if power is lost.

Approvals: CE Approved



Pulse Inputs: Various inputs may be ordered from standard plug-in input cards.

2A: Simultaneous Pulses:

Use for count or rate modes only. Separate pulses on input A count up, pulses on input B count down without loss of count even if pulses come at the same time. Open or 0 to 1VDC (low), 3 to 30VDC (high), 10 kOhm impedance. Max speed 10KHz (min. on/off .05 msec) (Internal switch to select debounce filtering to max. speed of 40, 400, or 10K Hz) (Board #2102)

3A: **Standard.** High Impedance Up/down Control. Use for count, time and rate modes. Input A accepts all pulses for count, rate, time stop. Input B controls direction of count (low: counts down, high: counts up), starts timer. Open or 0 to 1 VDC (low), 3 to 30VDC (high) 10K Ohm impedance. 100 kHz max. speed (min on/off 5 sec., 13 μ sec, if direction is changed). Min 13 μ sec delay required after up/down level change before count pulse. May be used with KEP encoder 715-2.

3B: Same as 3A input but has 4.7K Ohm input pull up resistors to +5VDC on inputs A and B for pulsing with contact to ground or NPN open collector transistor.

3C: High Impedance Separate Up/down: Use for count or rate modes only. Same specs as input 3A but separate pulses on input A count up, pulses on input B count down. Inputs must be normally low. (If input A is high, input B counts up on positive edge. If input B is high input A counts down on positive edge). May be used with KEP encoder 715-1.

3D: Same as 3C input but has 4.7K Ohm input pull-up resistors to 5VDC on inputs A and B.

NOTE: Inputs 3A, 3B, 3C, 3D as well as debounce filtering to max. speed of 40, 400 or 100 kHz are selectable by internal switches on any series 3 input card.

4A: Optically Isolated Up/down Control 5 to 12VDC: Use for count, time and rate modes. Input A accepts all pulses for count, rate, time stop. Input B controls direction of count (low: counts down, high: counts up), starts timer. Open or 0 to 1.5VDC (low), 5 to 12VDC (high), 1.1K Ohm impedance. Max speed 1500 Hz (min. on/off .33 msec. Min. count delay after up/down change.

4B: Same as 4A, but input voltage is open or 0 to 2 VDC (low), 12 to 24 VDC (high), impedance 2.2K Ohm.

4C: Optically Isolated Separate Up/down, 5 to 12VDC: Use for count or rate mode only. Same specs as input 4A, but separate pulses on input A count up, pulses on input B count down. Inputs must be normally low. (If input A is high, input B counts up on negative edge If input B is high, input A counts down on positive edge).

4D: Same as input 4C but input voltage is open or 0 to 2 VDC (low) 12 to 24 VDC (high), impedance 2.2K Ohm.

NOTE Inputs 4A, 4B, 4C, 4D as well as debounce filtering to max. speed of 40 or 1500 Hz are selectable by internal switches on any series 4 input cards. (#2098)

9A: Quadrature Input: Use for count or rate mode only. Accepts pulses 90° out of phase for up/down counting. Open or 0 to 1VDC (low), 3 to 30 VDC (high), 10K Ohm impedance, 20 kHz max speed (min on/off .025 msec) (Internal switch to select debounce filtering to max. speed of 40, 400 or 20 kHz.) (Board #2135) May be used with KEP 716 encoder

1A: Quad (x2) 5-30 VDC

1B: Quad (x4) 5-30 VDC

Reset: Front push-button CLR and remote reset input requirements follow pulse input selected. High level reset overrides other inputs. Min. on time, 5 msec.

Scaling: Any input from an external source or the internal time base can be multiplied by any number from 0.0001 to 99.9999. Press C to see scale factor. To change scale factor, press CLR and key in new factor. Press ENT to load in the displayed factor.

Preset: Two levels (8 digits) or one preset (8 digits) and one batch preset (8 digits). The preset numbers can be displayed or updated at any time by pressing A (preset A) or B (preset B). Enter the flashing preset number or press CLR and key in a new number and ENT to enter it. Output time from 0.1 sec. to 9.9 sec. or latched till reset is selected by RELAY mode set up.

NOTE The RATE METER mode has a floating decimal point. If a preset with a decimal is needed in the RATE METER mode only, use D to key in a decimal when setting up preset numbers. Outputs are active at or above preset rate and "off" below preset rate.

Control Outputs: (each of 2 outputs).

1. NPN transistor version: (Standard) Open collector sinks max. 250 mA from max. 30 VDC when active. (when relay is used, 10 VDC is provided at transistor outputs through relay coil. If greater than 2 mA is used, relay will remain energized. Applying greater than 10 VDC may destroy unit. Transistor will sink 100 mA in "on" state.)

2. SPDT Relay version: 10A 120/240 VAC or 28 VDC

Temperature: Operating +32°F (0°C) to +130 °F (+54°C).

Storage: -40°F (-40°C) to + 200°F (+ 93°C)

Mode Selection: All following functions are selected by front keypad. Following prompts written on the display, choose the basic device type, relay output operation, outcard data interface and panel lockout security code.

Ratemeter: Accurate to 51/2 digits ± 1 display digit. It can be programmed to accept almost any number of pulses per unit of measurement, sample from 2 to 24 seconds maximum, perform weighted averaging from 0.0 to 9.9. [(old data x wt + new data ÷ wt. + 1)] and auto-range up to 6 digits of significant information. Two levels of preset are standard. Outputs are active at or above the preset rate and return to the rest state when reading drops below the preset rate.

Counter: 8 digits of count with 2 levels of preset or 1 level of count preset and 1 level of batch preset Counter is designed to advance on negative edge of pulse. Choose between reset to zero or set to preset. Other choices include; manual reset, auto recycle at preset A, alternate action (counts to preset A, activates output A, counts to preset B, drops out output A.) or batcher. In the batch mode, the unit counts to preset A, activates output A, recycles and advances separate batch counter one count. At a preset number of batches output B is activated until batch counter is reset. At any time the display can be made to flash the batch total by pressing ENT while the unit is running. Activating CLR while the batch total is flashing resets the batch counter and the B preset output.

Timer: Choose from 1 to 10,000 pulses per second or minute basic time base with accuracy to +.015% and scale base from 0.0001 to 99.9999 to time in seconds, minutes, hours or days. Timing is controlled by positive edge of signal by one of three ways selected on the keypad:

Level: Times while input B signal is high

Pulsed: One positive pulse on input B starts timer, second positive pulse on input B stops timer

Start-Stop: Positive pulse on Input B starts timer, positive pulse on input A stops timer.

Once the time base is selected and the timing started, the unit operates much as a counter. All the features listed under "Counter" are available with the timer. (See section under "Counter" operating modes)

Relay: Control output timing is selected by pressing D until the RELAY mode is selected and entered. Time duration from .1 to 9.9 seconds (or 00 for latch output) may be entered for A and B outputs. Once the output has been activated, unit must be reset before another output will occur. The control output timing is independent of the counter/timer reset which is selected under its setup modes. In the RATE MODE of operation the outputs are active at or above the preset rate and return to the rest state when the reading drops below the preset rate.

Lockout: Unauthorized front panel changes can be prevented by entering a user selected 4 digit code in the LOCK-OUT mode. The status of the unit can be observed but "LOCKOUT" appears if changes are attempted. Entering the code returns the unit to "LOCK OFF" status.

Outcard: RS232 or RS422 serial 2 way communication options are available. Up to 15 units can be linked together and addressed separately to transmit unit status or accept new set points in the standard ASCII format. Baud rates of 300, 600,1200, 2400, 4800 or 9600 as well as choice of odd, even, space or mark parity can be selected by keypad control.

Opt 1: RS 232 serial interface.

Opt 2: RS 422 serial interface.

How To Order:

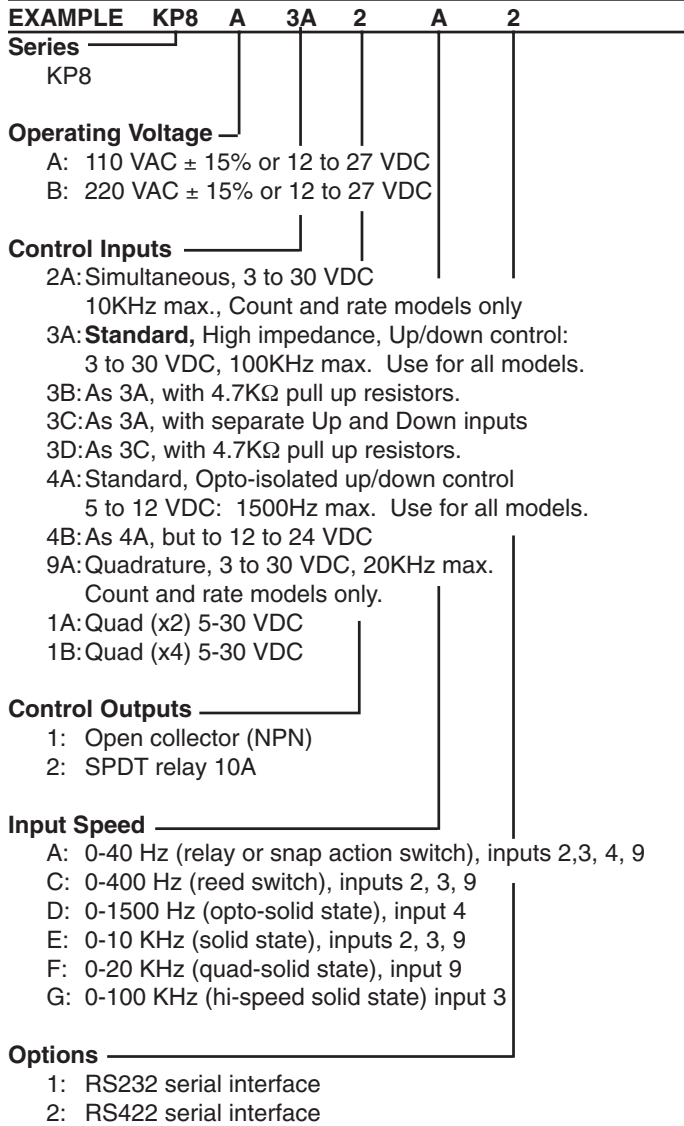

Terminations:

- 1• Opto Input Common
 - 2• Not Used
 - 3• Input B (Cnt Dwn, Up/Dn Ctrl, Start)
 - 4• Input A (Cnt Up, Rate, Time Stop)
 - 5• Reset Input
 - 6• Not Used
 - 7• Not Used
 - 8• Not Used
 - 9• Not Used
 - 10• Not Used
 - 11• Ground (-DC)
 - 12• Ground (-DC)
 - 13• +12 Volts Out
 - 14• +DC Power In
 - 15• Isolate -12 Volts
 - 16• Isolate +12 Volts
 - 17• AC In
 - 18• AC In
 - 19• Preset B Transistor
 - 20• Preset A Transistor
-
- | | |
|-------------------------------------|-----|
| <input type="checkbox"/> R1• N.O. | — A |
| <input type="checkbox"/> R2• N.C. | |
| <input type="checkbox"/> R3• Common | — B |
| <input type="checkbox"/> R4• N.O. | |
| <input type="checkbox"/> R5• N.C. | |
| <input type="checkbox"/> R6• Common | |

Mounting:

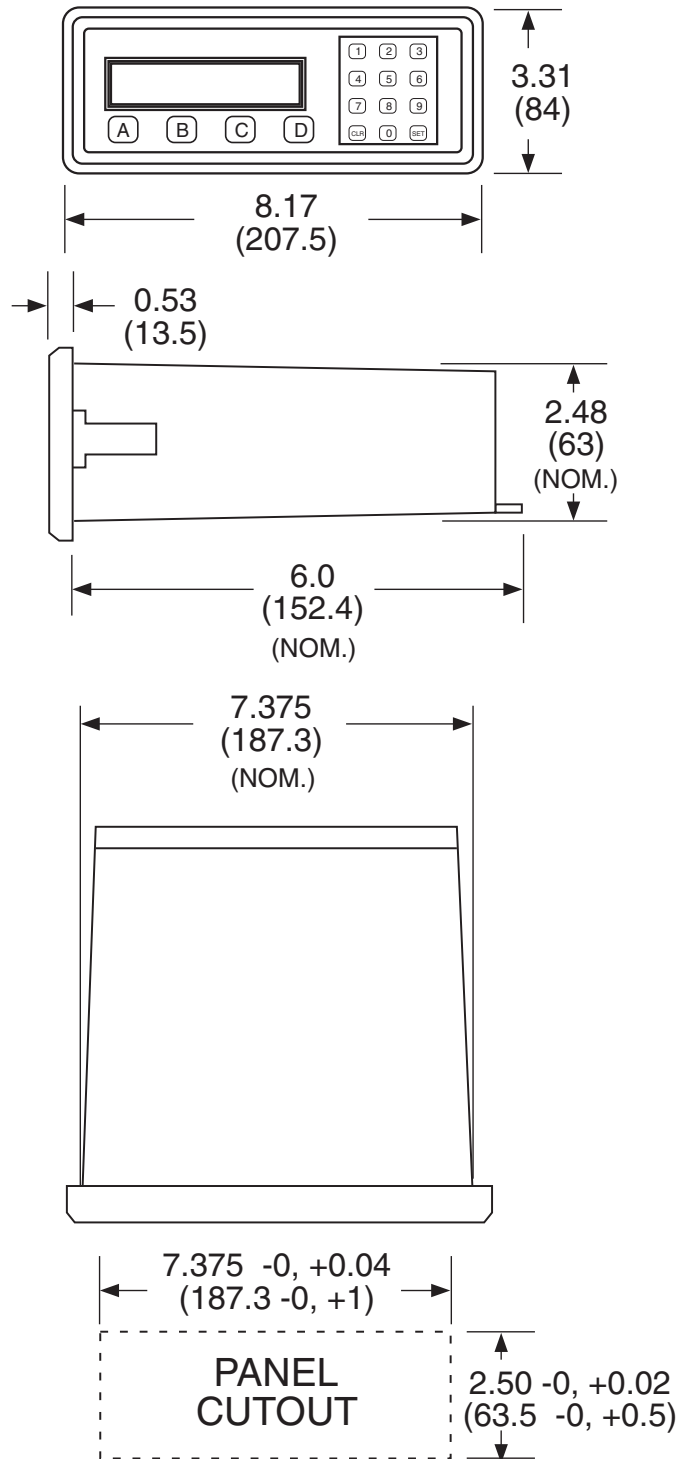

POSITROL

Low Cost, Pulse Input Position Monitor

Features

- 2 Control Set Points with Selectable Start Point
- 5 Digit Floating Point Decimal Scaling Factor
- Display From -99999 to 999999
- Pulse Input - 30 kHz Maximum
- Separate Up and Down Inputs
- Quadrature & Pulse Input with Up/down Control
- NEMA 4X / IP65 Sealed Front Panel

PRESET COUNTERS



Application:

Any position monitoring application where 2 alarm set-points and a 6 digit LED display is needed, such as blade positioning, box making and many other machine shop and industrial applications.

Description:

Featuring 6 digits of bright, 7-segment LED displays, the Positrol is a position monitor which accepts signal inputs up to 30 kHz. A 5 digit floating decimal scale factor allows a readout in true engineering units. The unit has two, programmable alarm set points from -99999 to 999999 and a selectable start point. These setpoints control two 5 Amp relays. A two stage panel lock prohibits menu changes from unauthorized personnel.

Specifications:

Display: 6 digit, .55" high, 7 segment, red orange, LED.

Input Power:

110 VAC \pm 15% or 12 to 15VDC.

220 VAC \pm 15% or 12 to 15VDC.

Current: 300 mA DC max or 8.0 VA at rated AC voltage.

Output Power: (AC powered units only)

+ 12VDC @ 50mA **unregulated** -10 +50%

Temperature:

Operating: +32°F (0°C) to +130°F (+54°C).

Storage: -40°F (-40°C) to +200°F (93°C).

Memory: EEPROM stores data for ten years if power is lost.

Inputs: DC pulse input open or 0-1 VDC (low), 4-30 VDC (high), 30 kHz speed max.

Reset:

Front Panel: resets display to view (start) value.

Remote: 4-30VDC positive edge, Resets display to view (start) value.

Lockout: Unauthorized front panel changes can be prevented by entering a user selected, 5 digit code. The lockout feature can be programmed to lock the entire front panel or lock the menu items and leave the presets and reset accessible. In either mode the locked items can be viewed but not changed.

Control Outputs: 2 each N.O. Relays - 5 Amp @ 120/240 VAC or 28 VDC. (N.C. Relay contacts or NPN sink from 10 VDC to .5 VDC @ 100 mA available with solder jumpers). The output will remain active when the display is equal to or greater than the set point. If the display falls below the set point, the output becomes inactive.

Set Points: Two control set points are provided. The set points can be programmed for any number from minus 99999 to plus 999999. The Positrol will recognize new set point values without the need to reset the unit. The unit also has a starting point which can be viewed or changed by pressing the "view" button. When the reset is activated, the display will reset to the view (start) value.

Shipping Weight: 2 pounds.

Approvals: CE Approved

Typical Application:

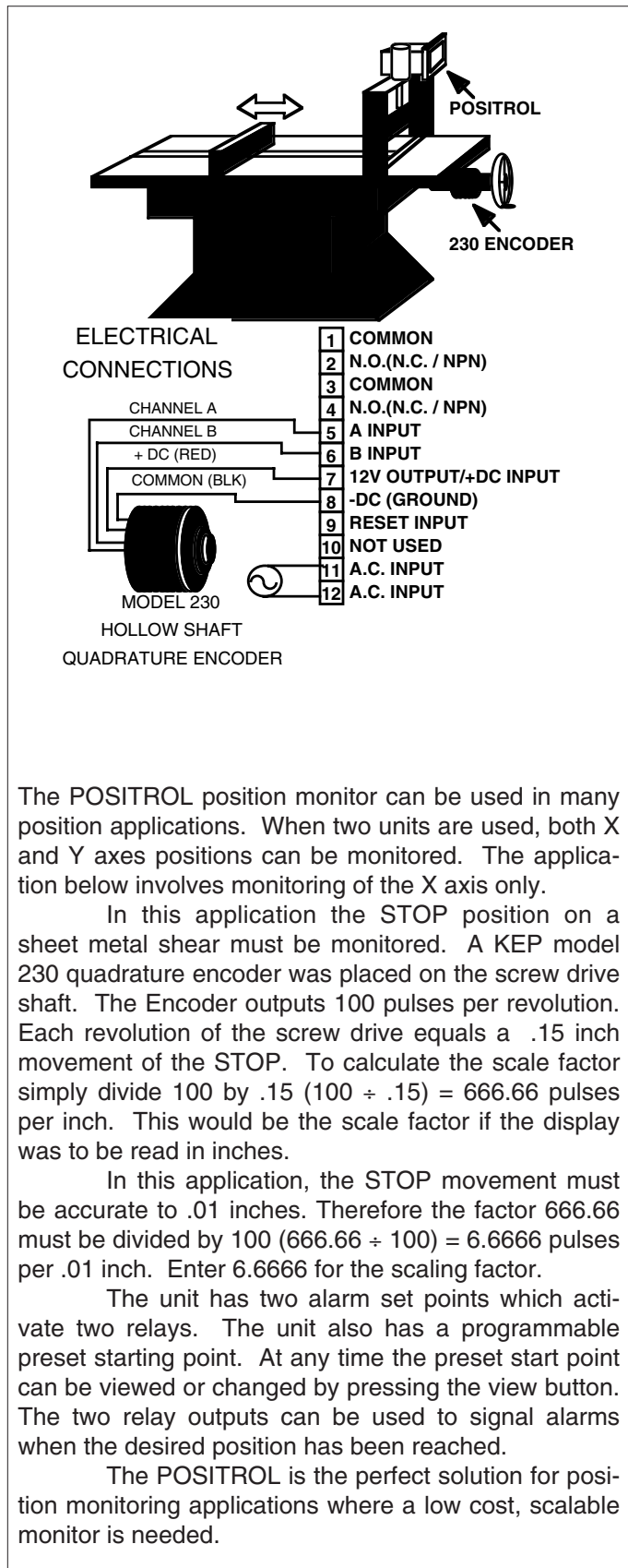

The POSITROL position monitor can be used in many position applications. When two units are used, both X and Y axes positions can be monitored. The application below involves monitoring of the X axis only.

In this application the STOP position on a sheet metal shear must be monitored. A KEP model 230 quadrature encoder was placed on the screw drive shaft. The Encoder outputs 100 pulses per revolution. Each revolution of the screw drive equals a .15 inch movement of the STOP. To calculate the scale factor simply divide 100 by .15 ($100 \div .15 = 666.66$ pulses per inch. This would be the scale factor if the display was to be read in inches.

In this application, the STOP movement must be accurate to .01 inches. Therefore the factor 666.66 must be divided by 100 ($666.66 \div 100 = 6.6666$ pulses per .01 inch. Enter 6.6666 for the scaling factor.

The unit has two alarm set points which activate two relays. The unit also has a programmable preset starting point. At any time the preset start point can be viewed or changed by pressing the view button. The two relay outputs can be used to signal alarms when the desired position has been reached.

The POSITROL is the perfect solution for position monitoring applications where a low cost, scalable monitor is needed.

Dimensions:

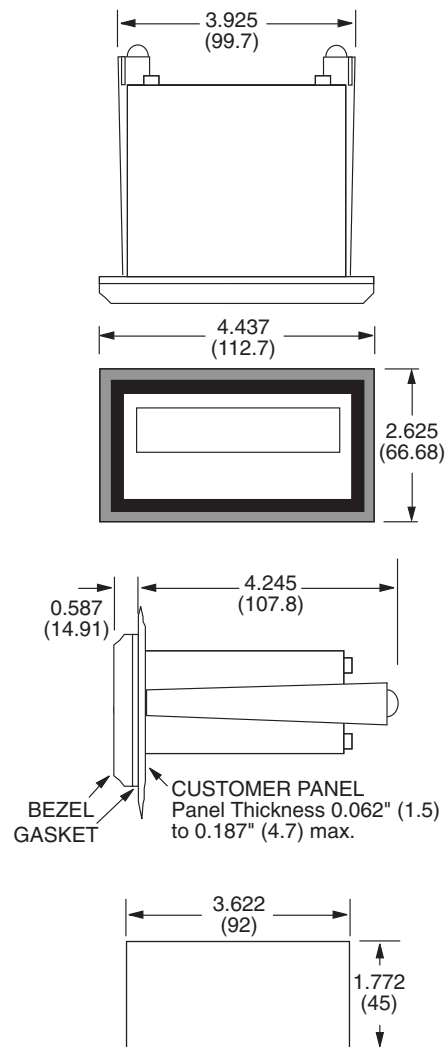

How To Order:

SAMPLE:	PM2	A	3
Series	PM2 Position Monitor		
Operating Voltage	A= 110 VAC \pm 15% or 12 to 15 VDC B= 220 VAC \pm 15% or 12 to 15 VDC		
Inputs	3 = Separate Up / Down Inputs 5 = One Count Input, One Up / Down Control 9 = Quadrature		

Accessories

Separate non keyboard panel order #34235
Separate keyboard panel - order #34237

SHIFT-TROL

Low Cost, Pulse Input Productivity Shift Monitor

Features

- Monitor Up to 4 Separate Shifts
- Separate 5 Digit Preset Counter
- Separate 5 Digit Scaling Factors For Shifts and Preset Counter
- Pulse Input - 10 kHz Maximum
- EEPROM Memory Stores All Program & Data Values For 10 Yrs.
- 1/8 DIN Cutout
- NEMA 4X / IP65 Sealed Front Panel

PRESET COUNTERS

Application:

Any piece-work application where several production shifts must be monitored. The Shift-trol shift monitor is especially useful in the Textile industry.

Description:

Featuring 6 digits of bright, 7-segment LED displays, the Shift-trol is a shift monitor which accepts signal inputs up to 10 kHz. The 5 digit dividing scale factors allow readouts in true engineering units. The unit has two, programmable alarm set points. These setpoints control two 5 Amp relays. A two stage panel lock prohibits menu changes from unauthorized personnel.

Specifications:

Display: 6 digit, .55" high, 7 segment, red orange, LED.

Input Power:

A) 110VAC \pm 15% or 12 to 15VDC.

B) 220VAC \pm 15% or 12 to 15VDC.

C) 24VAC \pm 15% or 12 to 15VDC.

Current: maximum 300 mA DC or 8.0 VA at rated AC voltage.

Output Power: (AC powered units only)
+12VDC @ 50mA **unregulated** -10 +50%

Temperature:

Operating: +32°F (0°C) to +130°F (+54°C).

Storage: -40°F (-40°C) to +200°F (93°C).

Shift Counters: 5 digit display with a 5 digit dividing scale factor. The unit can monitor up to 4 separate shifts and can be ordered with a selectable fifth shift, grand total of shifts or a run time meter. Pressing the view button allows the operator to alternately view each shift, the preset counter, the ratemeter and the selected fifth shift, grand total or run time.

Input Signals:

4 to 30 VDC pulses (open or 0-1V low; 4-30V high).

MIN. ON/OFF PULSE WIDTH: (Pin 5)

High CPS: .05 msec. 10 kHz max.)

Low CPS: 12.5 msec. (40 Hz max.)



Preset Counter: 5 digit display with a 5 digit dividing scale factor. Two, 5 digit, programmable setpoints are available for output control. Display flashes when either output is active.

Ratemeter: Accurate to 4 1/2 digits. The ratemeter displays the RPM (rate per minute) of the raw input data.

Memory: EEPROM stores data for ten years if power is lost.

Reset:

Front Panel: resets displayed value and updates averaged rate to new sample.

Two Level Remote: 4-30VDC positive edge (Min. on: 12 msec.);
1. (Pin 9) Resets preset counter and control output only. 2. (Pin 6)-"Input B": Resets displayed value and updates averaged rate to new sample.

Lockout: Unauthorized front panel changes can be prevented by entering a user selected, 5 digit code. The lockout feature can be programmed to lock the entire front panel or lock the menu items and leave the presets and reset accessible. In either mode the shifts can be changed and the locked items can be viewed but not changed.

Serial Communications: RS232 or RS422 serial communication options are available. Up to 99 units can be networked to a computer and individually accessed. Information can be retrieved as well as sent to any single unit in the loop. A programmable print list is provided for strobed data transmission to printers and other peripheral devices.

Control Outputs:

2 each N.O. Relays - 5 Amp @ 120/240 VAC or 28 VDC. (N.C. Relay contacts or NPN sink from 10 VDC to .5 VDC @ 100 mA available with solder jumpers). The output will activate when the display is equal to or greater than the set point.

Shipping Weight: 2 pounds.

Approvals: CE Approved

TYPICAL APPLICATION:

NEED:

A company in the textile industry has a rib machine for which four shifts and machine run time must be monitored. To achieve optimum production, the monitoring system must also include the speed of the machine as well as a preset counter (doff counter). This system will be installed in several rib machines. The individual systems must be networked together allowing a host computer to access processing and data information.

SOLUTION:

The company purchased the Shift-trol (ST3A1) and the D08P proximity sensor. The prox. sensor was mounted to sense each rotation of the machines shaft. It takes 579 rotations of the shaft for one yard of material to be produced. Therefore the scaling factor for the shifts was set at 579. The preset counter (doff counter) is to read in tenths of hanks. Therefore the scaling factor for the preset counter was set at 27792 (579 x 48; "48 yards in a tenth of a hank"). The Shift-trols were ordered with RS232 communication and were linked to a host computer. Each Shift-trol was assigned a unique ID number so each work station can be individually addressed. All of the process and data information can be accessed and recorded by the host computer.

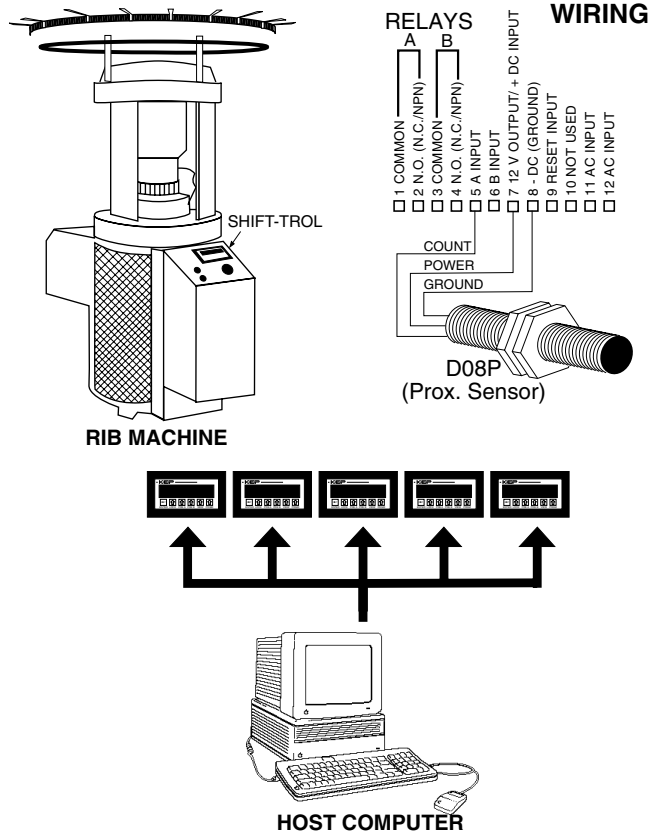

DIMENSIONS:

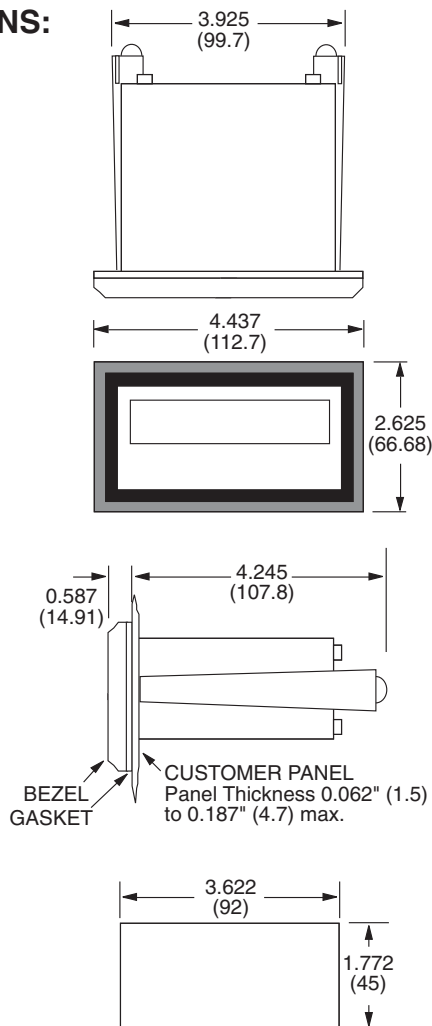

How To Order:

EXAMPLE: ST3	A	1
Series _____		
ST0: 3 shifts, no scaling, 1 separate preset counter with 1 control output		
ST1: 3 shifts, scaling, 1 separate preset counter with 1 control output		
ST2: 3 shifts, scaling, 1 separate preset counter with 2 control outputs		
ST3: 4 shifts, scaling, 1 separate preset counter with 2 control outputs, 1 separate RPM ratemeter of unscaled input data, selectable: Grand Total, 5th Shift or Run Time.		
ST4: 3 shifts, scaling, 1 separate preset counter with 2 control outputs, 1 separate ratemeter with separate scaling, selectable: Grand Total, 4th Shift or Run Time.		
Operating Voltage _____		
A= 110 VAC ± 15% or 12 to 15 VDC B= 220 VAC ± 15% or 12 to 15 VDC C= 24 VAC ± 15% or 12 to 15 VDC		
Options _____		
1 = RS232 Communications 2 = RS422 Communications		

Accessories

- Separate non keyboard panel order #34235
- Separate keyboard panel - order #34237

KALTROL-SP

Self Powered, Preset Counter Replaces Electro-Mech. Counters

PRESET COUNTERS

Features

- Internal Battery Powered (8 years)
- Programmable N.O. or N.C. Relay Output
- Replaces Electro-Mechanical Units
- 6 Digit LCD Display
- Main & Lower LCD Displays Indicate Counter and Preset Values without External Power
- Add or Subtract Count Control
- Optically Isolated Count and Reset Inputs

Applications:

Batch counting and control, coil winding and wire cutting, length measurement, packing-line control, stop/start control and numerical position control.

Specifications:

Display: 2 lines of 6 digits, black on silver background. Main display .275" (7mm); indicates count value. Bottom display .157" (4mm); shows preset set point, "output on" and "low battery" indicators.

Preset Point: Single preset, user selectable: count up with output at preset (add), or count down with output at 0 (sub).

Reset: Manual, electrical and automatic. User selectable for reset to zero (add) or reset to the preset value (sub).

Inputs: (Count & Reset)

Count Speed: Max. 35 Hz (min. 14 mSec On/Off)

Reset: Edge Triggered, Minimum pulse 50 mSec

Optocoupled (STD) KAT-SP:

Low: Open or 0 to 2V

High: 12-250 VAC/VDC

Input Impedance: 100 k Ω

Switch Closure (Option S) KAT-SPS:

Low: 0 to 0.8V

High: Open or 2 to 5 VDC

Sink Current 5 mA, (DO NOT EXCEED 5 VDC)

Programming: Via six front-panel digit keys (one key assigned to each digit) and one front-panel reset key.

Output: Relay (N.O. or N.C.) self latching, contacts rated at 2A @ 30VDC, 0.5A @ 240VAC resistive load. In the manual reset mode (loop off), the output will remain latched until reset. In the auto-reset (loop on) mode the output will remain "on" for a user selectable time delay (100 to 500 msec.).

Batteries: Two internal, customer replaceable 3V lithium batteries provide power and data retention for up to 8 years (calculated at 5 x 10⁶ power operations @ 25°C).

Battery Monitor: Subsidiary display shows LO-BAT when batteries require replacement.

Noise Immunity: To VDE 843, Part 4, Severity 3

Temperature Range:

Operating: +14°F to +122°F (-10°C to +50°C)

Storage: -4°F to +140°F (-20°C to +60°C)

Protection: Front Panel is NEMA 4/IP65 sealed

Weight: Approx. 80 g

Approvals: CE Approved



Operating The Counter:

Setting or Resetting

Press the red SET button or apply a pulse to the reset input to set the counter to zero (add) or the preset (sub).

Presetting

The preset is displayed on the lower line of the display. To set the preset, use the 6 keys assigned to the 6 digits. The unit must be reset to accept the new preset value.

Overflow and Underflow

In the adding mode the overflow is 999999 to 0; In the subtracting mode it is 0 to 999999. The output signal remains unaffected.

Lo-Bat Indicator

When the battery charge is too low, "Lo-bat" will appear on the lower line of the display and flash in 2 second intervals. When "Lo-bat" is indicated, the batteries should be replaced as soon as possible.

Changing the Batteries

Push the battery cover back and remove the batteries. Insert the replacement batteries making certain that the polarity is correct (observe "-" terminal on PCB).

Note: If the battery replacement takes longer than 7 minutes, the count, preset and program parameters will be lost. If this occurs, the unit will automatically enter the programming mode upon battery installation.

KAT-SP Wiring Connections:

(Standard KAT-SP Opto Input)

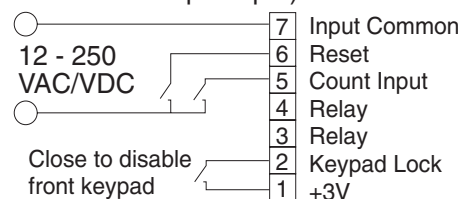

KAT-SPS Wiring Connections:

(Optional KAT-SPS Switch Closure Input)

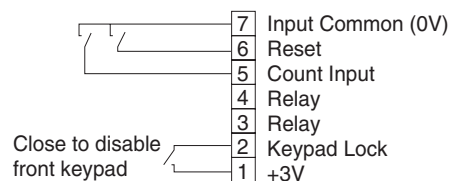

Entering Programming Mode:

Press the reset key together with the keys of decade 5 and 6 to enter the programming mode. On the lower line of the display the message "INIT" appears together with a down counter subtracting from 5 to 0 seconds. If the keys are released when the counter equals 5, the display will enter an LCD test. Releasing the keys at any time when the counter is greater than one, the display will return to the operating mode. If the keys are released after reaching zero, the programming mode will become active.

Setting the Operational Parameters:

Key 1 allows the user to choose requested functions within the parameters (i.e. add/subtract). Key 6 selects the displayed choice and advances to the next selection. After the last parameter "dp", the program jumps to the beginning. To exit the programming mode, the user must step through all the parameters (from beginning to end) with NO CHANGES at all.

NOTE: Whenever the programming mode is entered, the program jumps to the beginning, the previous parameters will be lost and the count and preset will be zeroed. If a battery change takes longer than 7 minutes, the display will automatically advance to the programming mode.

Programming Flowchart:

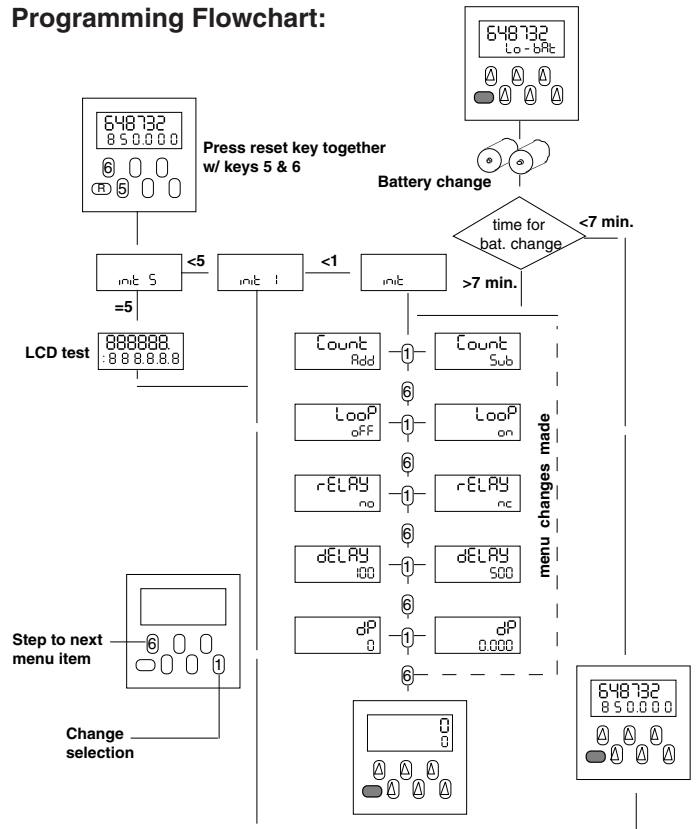

Dimensions:

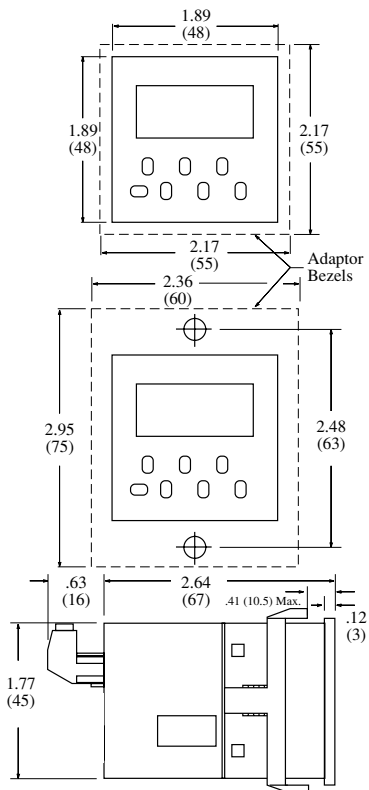

Panel Cutout:

Bezel Size	Cutout
1.89 x 1.89 (48 x 48)	1.77 x 1.77 (45 x 45)
2.17 x 2.17 (55 x 55)	1.97 x 1.97 (50 x 50)
2.95 x 2.36 (75 x 60)	1.77 x 1.77 (45 x 45)
	1.97 x 1.97 (50 x 50)
	w/ Screw Holes

Adaptor bezels supplied:

2.17 x 2.17 (55 x 55) or 2.95 x 2.36 (75 x 60)

Menu Prompts:

Count Add	Counter will count up and output at preset
Count Sub	Counter will count down from preset and output at zero
Loop on	Counter will Auto-reset at preset (add); zero (sub).
Loop off	Counter will continue to count past preset (add); zero (sub).
rELAY nc	Relay is normally closed (opens at preset)
rELAY no	Relay is normally opened (closes at preset)
dELAY 100-500	The output delay (duration) in msec., ignore if Loop off.
dp	Decimal Point location 0 to 0.000

How To Order:

- KAT-SP** (opto input)
- KAT-SPS** (switch closure input)
- N7** - Explosion proof housing (see accessories section)
- KATSP-BAT** Replacement Battery (2 required)

903K & 904K

LCD Preset Add/Subtr. Counter, Timer, Frequency Meter

PRESET COUNTERS

Features

- 6 Digit Counter, Timer or Frequency Meter
- 2 Preset Values (Type 903K 1 Preset)
- Input Scaling (0.0001 to 9.9999) Multiplier
- 2-Line LCD Display
- Count & Preset Range of -999999 to 999999
- Add or Subtract Count Control
- AC or DC Operation
- Secondary Preset Batch Counter (904K)
- 24VDC to Power Peripherals



Applications:

Preset batch counting, length measuring, simple positioning, time control, speed control, rate control.

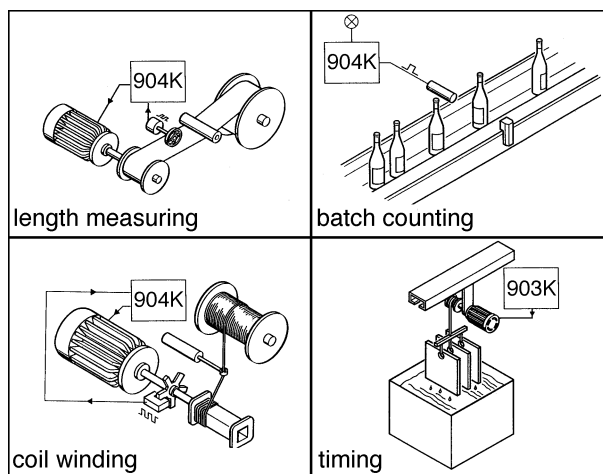

Description:

The 903K/904K Series is a LCD preset counter, timer or frequency meter. The following features are programmable:

- operating mode, polarity of inputs, input mode, multiplying factor, decimal point.
- output signals to be permanent or timed
- automatic reset
- gate time when programmed as a frequency meter
- timer resolution (s, min, h or h:min:s)

Inputs:

INP A, INP B

Count inputs. Max. count frequency 30 Hz or 10 kHz; separately selectable for both of these inputs.

Gate:

Level input; no counting while this input is activated.

Reset:

Edge triggered input; it is connected in parallel to the red reset key and sets the counter to zero (adding mode) or to the preset value (subtracting mode).

Key:

Level voltage input locks keypad.

Outputs:

2 potential-free outputs (Type 903: 1 output), versions with relay or optocoupler available.

Programming:

Types 903 and 904 are programmed by 4 front panel keys secured by a side dip switch. Easy setup is assured by selection of menu prompts on the display. The changing of presets by the front panel keys can be inhibited by external "Key" input.

Input Polarity:

Positive (PNP) or negative (NPN). The selected polarity applies to all inputs in common.

Operating modes, Impulse Counter and Timer:

- adding, starting at zero, manual or automatic reset
- subtracting, starting at the preset value (Type 903) respect. at preset value 2 (Type 904), manual or automatic reset.

Input modes, Impulse Counter and Frequency Meter:

- E1: 1 count input, 1 count direction input
- E2: 1 count input up, 1 count input down
- E3: quadrature input
- E4: quadrature input with pulse doubling

Decimal places:

The values may be displayed without, with one, two or three decimal places.

Scaling factor:

A scaling multiplier of 0.0001 ... 9.9999 may be programmed to display desired units of measure.

Output signal:

Selectable as a NO contact, NC contact, positive, negative, latched or timed (0.01 s to 99.99 s).

Gate time (Frequency Meter):

Selectable from 0.01 s to 99.99 s.

Hour Meter:

Timing in h, min or s, with a resolution of 0.001, 0.01, 0.1, 1.0 or h:min:s.

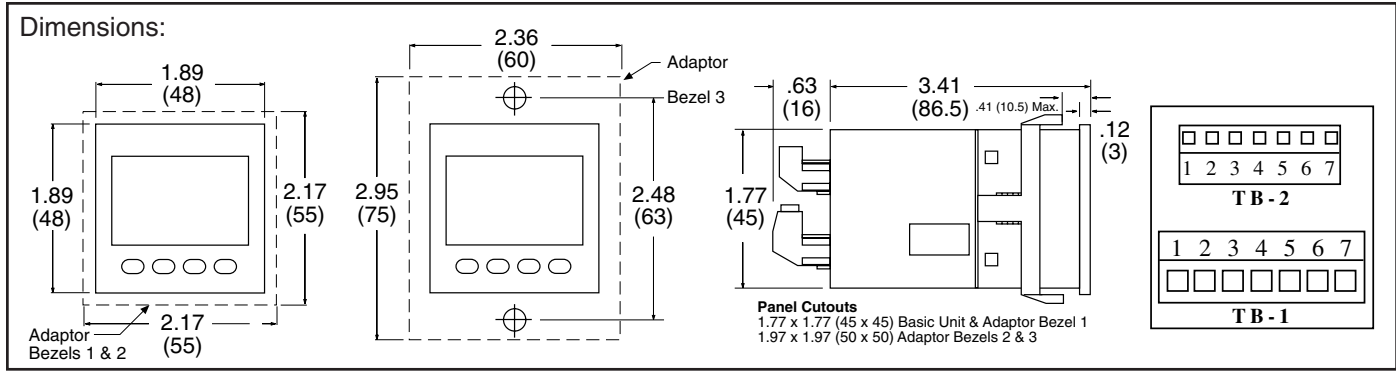

903K Wiring

AC Supply Wiring

TB-1		TB-2	
Term. #	Description	Term #	Designation
1	No Connection	1	+24VDC Output
2	No Connection	2	0VDC (Ground)
3	Relay - C (Opto Emitter)	3	Input A
4	Relay - NO	4	Input B
5	Relay - NC (Opto Collector)	5	Reset
6	AC Input	6	Gate
7	AC Input	7	Key

DC Supply Wiring

TB-1		TB-2	
Term. #	Description	Term #	Designation
1	No Connection	1	No Connection
2	No Connection	2	No Connection
3	Relay - C (Opto Emitter)	3	Input A
4	Relay - NO	4	Input B
5	Relay - NC (Opto Collector)	5	Reset
6	(+) 11-30 VDC Supply	6	Gate
7	(-) 0 VDC Supply (Ground)	7	Key

904K Wiring

AC Supply Wiring

TB-1		TB-2	
Term. #	Description	Term #	Designation
1	Relay 1 - C (Opto Collector1)	1	+24VDC Output
2	Relay 1 - NO (Opto Emitter1)	2	0VDC (Ground)
3*	Relay 2 - C (Opto Emitter2)	3	Input A
4	Relay 2 - NO	4	Input B
5*	Relay2 - NC (Opto Collector2)	5	Reset
6	AC Input	6	Gate
7	AC Input	7	Key

DC Supply Wiring

TB-1		TB-2	
Term. #	Description	Term #	Designation
1	Relay 1 - C (Opto Collector1)	1	No Connection
2	Relay 1 - NO (Opto Emitter1)	2	No Connection
3*	Relay 2 - C (Opto Emitter2)	3	Input A
4	Relay 2 - NO	4	Input B
5*	Relay2 - NC (Opto Collector2)	5	Reset
6	(+) 11-30 VDC Supply	6	Gate
7	(-) 0 VDC Supply (Ground)	7	Key

* The wiring termination of pins 3 & 5 is correct here and on the unit termination label. Pins 3 & 5 may be reversed on some older datasheets.

Technical Data:
Display: 6 digit, 2-line, 7 segment LCD with sign
Preset: Type 904 two preset values
 Type 903 one preset value

Supply voltage: 115 VAC, 230 VAC, 48 VAC or 24 VAC (tolerance ± 10%) or 11 ... 30 VDC

Count inputs: 2 count inputs, 4 input modes programmable.

Input polarity: programmable (PNP or NPN)

Input resistance: 10 kohm

Max. count frequency: 10 kHz (Switch selectable 30Hz or 10kHz)

Min. pulse length of the control inputs: 5 ms

Input sensitivity: Logic "0": 0 to 1 VDC
 Logic "1": 4 to 30 VDC

Pulse shape: variable (Schmitt Trigger characteristic)

Output: (Programmable output state)
 relay (250 V @ 3A)
 or optocoupler (30VDC/15mA @ 2V, 5mA @ 0.4V)
 903: 1 output : SPDT
 904: 2 outputs: R1 N.O., R2 SPDT

Transmitter voltage: 24 VDC, 80 mA
 24 VDC, 60 mA for version with backlit LCD (optional)

Data retention: min. 10 years or 10⁶ memory cycles

Noise immunity: EN 50082 part 2

Noise transmission: EN 55011 class B

Operating temperature: 0...+50°C

Housing: 48 x 48 mm DIN

Protection: IP 65 (front)

How To Order:

EXAMPLE	904K	A	0	A
Series	_____			
903K = Single Output				
904K = Dual Outputs				
Operating Voltage	_____			
A = 115 VAC				
B = 230 VAC				
C = 11 to 30 VDC				
Outputs	_____			
0 = Relay				
1 = Opto-Isolated collector and emitter				
Options	_____			
- Blank if None				
A = Backlit LCD Display (904K only)				

TR-545 Series

Totalizer and Ratemeter

Features

- Totalizer and Rate meter
- Separate scaling factor for counter and ratemeter
- Ratemeter displays frequency or RPM
- Simply press key to switch between counter and ratemeter
- Display range: 0 to 999999
- Screw terminal connections



Description:

The TR-545 is a totalizer and ratemeter. It accepts DC pulse inputs up to 20kHz. It is a perfect solution for all applications requiring the monitoring of rate and total.

Specifications:

Supply voltage: 10 to 30 V DC, with reverse polarity protection
90 to 260 V AC 50/60 Hz
mains hum suppression

Power consumption: max. 2 W/6 VA

Display: 6-digit, red 7-segment LED's
height 14 mm

Data backup: EEPROM

Housing: housing for control panel 96 x 48 mm acc. to DIN 43 700;
RAL 7021, dark grey

Polarity of Inputs: programmable, npn or pnp for all inputs

Input resistance: appr. 10 k Ω

Input frequency: 20 kHz, can be damped to 30 Hz

Reset time: 5 ms

Level of inputs:

DC-version
Low: 0 to 0.2 x UB [V DC]
High: 0.6 x UB to 30 V DC

AC-version
Low: 0 to 4 V DC
High: 12 to 30 V DC

DC Output: 24 V DC \pm 15 %/100 mA (AC powered units only)

Accuracy: Ratemeter: <0,1 %

Ambient temperature: -10 to +50°C

Storage temperature: -25 to +70°C

EMC: according to EC EMC directive 89/36/EWG

Interference emissions: EN 50081-2/EN 55 011 class B

Interference resistance: EN 6100-6-2

Protection: NEMA4/IP65 (front panel)

Weight: appr. 150 g

Wiring Connections

Rear View

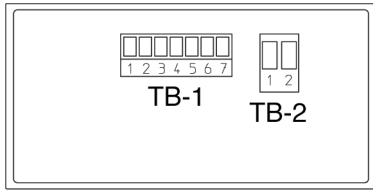

TB-1 Measurement Inputs

Pin	AC-Version	DC-Version
1	n.c.	
2	n.c.	
3	Reset	
4	n.c.	
5	INP	
6	GNDout	n.c.
7	+24 Vout	n.c.

TB-2 Supply Voltage and Outputs

Pin	AC-version	DC-version
1	90 ... 260 V AC	0 V DC (GND)
2	90 ... 260 V AC	10 ... 30 V DC

Dimensions

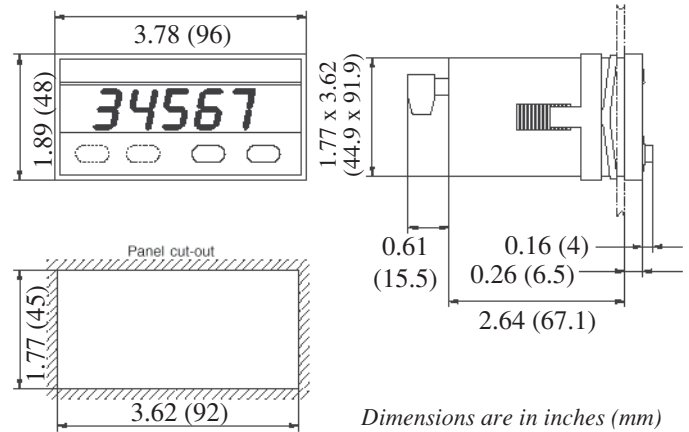

Order Code

Example:	TR544.012	0	00
Series:	TR-544 = Totalizer & Ratemeter		
Operating Voltage:	0 = 90 to 260 VAC 3 = 10 to 30 VDC		
Options:	00= None		

MRT (MINITROL)

Low Cost, Pulse Input Totalizer/Ratometer

Features

- CSA Approved
- Separate Scaling Factors For A & B Inputs
- Display Rate & Total
- Pulse Input - 10 kHz Max.
- RS422/RS232 Serial Communication
- Modbus RTU RS422/RS485/RS232
- NEMA 4X / IP65 Front Panel
- Separate Add/Subtract Simultaneous Inputs
- Quadrature & U/D Direction Control Inputs
- 30mV Magnetic Pickup Inputs
- 4-20mA or 0-20mA Analog Output

Application:

Any rate, total or blending application where 2 preset alarms and scaling are required.

Description:

The MINITROL is a 6 digit totalizer / ratemeter with two level, 5 digit preset alarm control of total or rate. Inputs A & B have separate scaling K-factors. The totalizer can be programmed for "A" subtract "B", "A" add "B" or A & B as separate totalizers, with display and control of the "net" total and rate of "A". The MINITROL is also available in 4 other versions. MC2: a two preset totalizer with scaling, MR2: a high/low alarm ratemeter with scaling; The "MC": a totalizing counter only, and the "MR": a rate meter display only. If only one input is required, the unit will display the total and rate from that one channel. The MINITROL can accept up to 10,000 pulses per second. It has a 5 digit floating decimal scale factor allowing total readout in true engineering units and rate per second, minute or hour.

Input "A" simultaneously drives a ratemeter which can be programmed to display the basic frequency (rate per second) or factored to show rate per minute or rate per hour. Simply push the "VIEW" button to see either total or rate without losing a count. Two separate 5 A relay contacts can be set to operate at either rate or total presets in a latch or auto-recycle mode with output timing from 0.1 to 99.9 seconds.

Two control outputs can be assigned to either the totalizer or ratemeter and can automatically recycle at the batch or stay latched until reset.

Up to 99 units can communicate to a host computer on a single RS232 or RS422 loop.

When two inputs are received (A & B), the unit can either add or subtract the two inputs or display the two inputs as separate totalizers.



Specifications:

Display: 6 digit, 0.55" High LED

Input Power:

110 VAC \pm 15% or 12 to 15 VDC
220 VAC \pm 15% or 12 to 15 VDC
24VAC \pm 15% or 12 to 15 VDC

Current: 250 mA DC max. or 6.5 VA AC

Output Power: (AC powered units only)
+12 VDC @ 50 mA, unregulated -10 + 50%

Temperature:

Operating:
+32°F (0°C) to +130 F (+54°C)

Storage:
-40 F (-40°C) to +200°F (93°C)

Humidity: 0-90% Noncondensing

Memory: EEPROM stores data for 10 years if power is lost.

Inputs:

- 3: High Impedance DC pulse input 4-30 VDC (high), Open or 0-1 VDC (low), 10 K Ω imp. 10 kHz max. speed. Accepts simultaneous inputs. May be used with KEF 711 series or 715-1 encoders or PD & D series sensors.
- 3M: Mag. Input, Input A only, accepts 30mV input (50 V max. P/P) signals 10 K Ω imp. 5 kHz max. (Input B, 4-30V)
- 3MB: Mag. Input, Inputs A & B, accepts 30mV input (50 V max. P/P) signals 10 K Ω imp. 5 kHz max.
- 5: 4-30 V Count pulses on Input A, 4-30 V Direction Control input (level) on Input B. May be used with KEF 715-2 Encoder.
- 5M: 30 mV Count pulses on Input A (50 V max. P/P) 4-30 V Direction Control input (level) on Input B.
- 9: Quadrature, accepts 4-30 V pulses with 90° phase shift for direction detection. May be used with KEF 716 encoder.
- 9MB: Quadrature, accepts 30 mV (50 V max. P/P) pulses with 90° phase shift for direction detection.

Approvals: CSA File# LR91109-7, CE Approved

Reset:

Front Panel:

Resets displayed value and control output

Remote:

4-30 VDC (75 - 240 V AC/DC, Input 8) negative edge resets Totalizer "A" and control output

Control Outputs:

Relays:

2 each N.O. Relay; 5 Amps 120/240 VAC or 28 VDC. (N.C. relay contacts and NPN transistor output available with solder jumpers. Transistor output is internally pulled up to 10 VDC through relay coil, sinks from 10 VDC to .5 V @ 100 mA)

Analog Output:

An optional 4-20mA (0-20mA) output is available for the Minitrol series. The output can be programmed to track rate or total. This feature is available by adding suffix A to the part number. Connections are via a 2 terminal pluggable screw connector.

Programming is accomplished by using the front panel in conjunction with rear dip switches.

Accuracy: ±.25% FS worst case.

Compliance Voltage: 3 to 30 VDC non inductive.

Scaling Factor (K-Factor): In the standard unit, a user programmable K-Factor is used to convert the input pulses to engineering units. The 5 digit K-Factor dividers, with decimal keyed into any position, allow easy direct entry of any K-Factor from 0.0001 to 99999. Separate factors may be entered for the 2 separate input channels.

Presets: Two control outputs are provided. To set relay values, press "menu" button until "Relay" appears on the display, the A and B outputs can be assigned to the ratemeter (high/low), one preset for rate and one for total, or two presets (2 stage shut off) on the A and B totalizers. A 5 digit value can be entered for both presets and the decimal point location is the same as the counter. The outputs can be set to energize from 0.1 to 99.9 seconds or latch (0.0). If a value other than 0.0 is entered, the totalizers will auto reset at the preset. In the A-B or A+B versions, the relays will be assigned to either net total or A rate.

Lockout: Unauthorized front panel changes can be prevented by entering a user selected 5 digit code in the "LOC" mode. The front panel can be completely locked out or the presets can remain accessible.

Ratemeter: Accuracy: 0.01% FS (±1 display digit).

The rate display updates once per second. The rate meter can be programmed to accept almost any number of pulses per unit of measurement, sample from 2 to 24 seconds maximum, and auto-range up to 5 digits of significant information. In the "RPS" mode, the ratemeter displays in units per second, and in the "scale" mode, units per hour or per minute. The unit will display the rate of the A Input only.

Totalizer: The two 6-digit totalizers can count at 10 kHz max. Each can have a 5-digit dividing scale factor. The totalizer advances on the positive edge of each pulse. Count up or down modes available, as are quadrature inputs from encoders for position or flow measurement. The unit can be programmed to view the net value of "A+B" or "A-B", or A and B as separate totalizers.

RS232/RS422 with KEP Protocol:

If the serial interface option is supplied, up to 99 units can be linked together. (The terminal addressing the unit must be capable of driving all loads in the loop.) Unit status and new set points can be communicated by serial communication. Mode changes, however, must always be made on the front panel.

Data is received and transmitted over standard EIA RS232 or RS422 levels. Unit number, baud rate and parity are entered in the "Program Setting" set up mode and remain in memory even if power is off.

RS232/RS422/RS485 with Modbus RTU Protocol:

The serial port can be used for serial printing or also for data acquisition. The unit can address up to 247 units (The terminal addressing the unit must be capable of driving all loads in the loop.) The unit can communicate with a master device through a Modbus-RTU protocol. The data given for each parameter is in IEEE float format comprising of 2 words. The unit can be connected in a network.

Device ID: 01-247

Baud Rates: 300, 600, 1200, 2400, 4800, 9600

Parity: None, Odd, Even

Protocol: Modbus RTU (Half Duplex)

Termination:

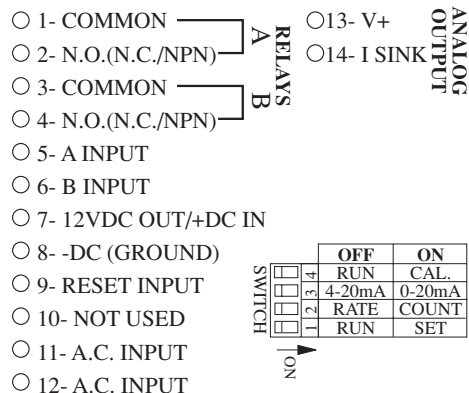

Mounting:

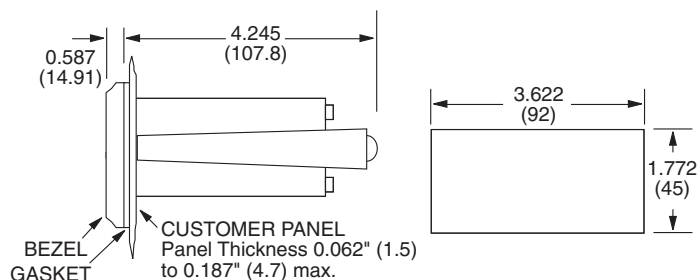
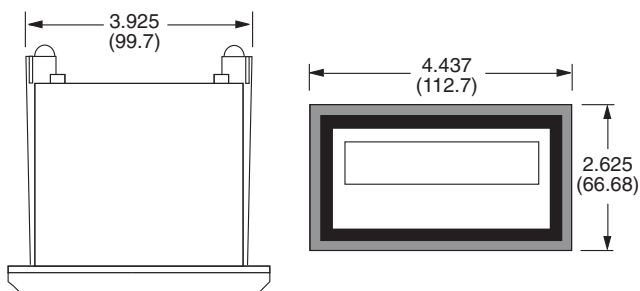

How To Order:

MINItrol (MRT, MC2, MR2)

Example:	MRT	A	3	1 A
Series:				
MRT=	6 digits, counter / ratemeter with presets and scaling.			
MC2=	6 digits, counter only with presets and scaling.			
MR2=	5 digits, rate only with presets and scaling.			
Operating Voltage:				
A=	110 VAC ± 15% or 12 to 15 VDC			
B=	220 VAC ± 15% or 12 to 15 VDC			
C=	24 VAC ± 15% or 12 to 15 VDC			
Count Inputs:				
3 =	Standard, 4-30 VDC simultaneous inputs.			
3M =	Mag. Input, Input A only, 30mV input (Input B, 4-30V)			
3MB =	Mag. Input, Inputs A & B, 30mV input			
5 =	4-30 V pulses on Input A, 4-30 V Direction Control input on Input B.			
5M =	30 mV pulses on Input A, 4-30 V Direction Control input on Input B			
9 =	Quadrature, accepts 4-30 V pulses			
9MB =	Quadrature, accepts 30 mV pulses (A & B)			
Options (Multiple Options Not Available)				
1=	RS232 Communications			
2=	RS422 Communications			
3=	Modbus RTU RS232			
4=	Modbus RTU RS422/RS485			
A=	Analog Output (4-20/0-20 mA)			

Accessories

Separate non keyboard panel order #34235
 Separate keyboard panel - order #34237

MINItrol (MR, MC)

Example:	MC	H	A	3	M (MR ONLY)	1
Series:						
MR=	5 digits, rate display only no presets, no scaling					
MC=	6 digits, dual input, bi-directional counter only, no presets, no scaling					
Input Speed:						
L =	Low speed input debounce filter 40 Hz max.					
H =	High speed input (0 to 9.99 kHz)					
Operating Voltage:						
A=	110 VAC ± 15% or 12 to 15 VDC					
B=	220 VAC ± 15% or 12 to 15 VDC					
C=	24 VAC ± 15% or 12 to 15 VDC					
Count Input:						
3 =	Standard, 4-30 VDC simultaneous inputs.					
3M =	Mag. Input, Input A only, 30mV input (Input B, 4-30V)					
3MB =	Mag. Input, Inputs A & B, 30mV input					
5 =	4-30 V pulses on Input A, 4-30 V Direction Control input on Input B.					
5M =	30 mV pulses on Input A, 4-30 V Direction Control input on Input B					
9 =	Quadrature, accepts 4-30 V pulses					
9MB =	Quadrature, accepts 30 mV pulses (A & B)					
Rate Time Base: MR ONLY						
S=	RPS (rate per second)					
M=	RPM (rate per minute)					
H=	RPH (rate per hour)					
Options: (Multiple Options Not Available)						
1=	RS232 Communications					
2=	RS422 Communications					

Accessories

Separate non keyboard panel order #34235
 Separate keyboard panel - order #34237

DRT (Dual rate/totalizer)

2 Separate Rate/Total Displays with Combination Function

Features

- Displays A,B,&C Rate & A,B,&C Total
- Separate Scaling Factors For A & B Inputs
- "C" Displays A+B, A-B, A÷B, & A÷A+B
- RS422/RS232 Serial Communication
- Modbus RTU RS422/RS485/RS232
- Pulse Input - 10 kHz Max.
- Security Lockout
- NEMA 4X / IP65 Front Panel
- 30mV Magnetic Pickup Inputs

DESCRIPTION:

The DRT (Dual Rate Totalizer) is a dual 5 digit Ratemeter 6 digit Totalizer in a 1/8 DIN package. User selects 1 of 6 displays to show A,B or C rate and A,B or C total. Inputs A and B have separate scaling to read in engineering units.

A 4-20mA (0-20mA) output of the C rate or total is optional.

The user can press the VIEW button to see 6 separate items total A, total B, total C, rate A, rate B, rate C. Negative values are displayed with a negative symbol (- 12345). For the C value, the user can choose from the following combination of A&B inputs: TOTAL; with a choice of A+B or A-B; RATIO with choice of A÷B(x100) to show percent of A to B quantity or A÷[A+B(x100)] to show percent of A to total quantity.

Two independent presets are standard. User selects whether output A is activated by total or rate value of input A or selected C. Output B can be activated by total or rate value of input B or selected C. Outputs activated by A or B total can be set to latch or autorecycle with an adjustable output duration from 00.1 to 99.9 sec. For rate, ratio, or C total outputs pull in when value is equal or above the preset and drop out when value is below the preset minus the selected 0 to 999 hysteresis.

SPECIFICATIONS:

DISPLAY:

6 digit, 0.55" High LED

INPUT POWER:

110 VAC ± 15% or 12 to 15 VDC

220 VAC ± 15% or 12 to 15 VDC

24VAC ± 15% or 12 to 15 VDC

CURRENT:

250 mA DC max. or 6.5 VA AC

OUTPUT POWER: (AC powered units only)

+12 VDC @ 50 mA, unregulated -10 + 50%

TEMPERATURE:

Operating:

+32°F (0°C) to +130 F (+54°C)

Storage:

-40 F (-40°C) to +200°F (93°C)

HUMIDITY:

0-90% Noncondensing

MEMORY:

EEPROM stores data for 10 years if power is lost.



- 4-20mA or 0-20mA Analog Output
- CSA Approved

INPUTS:

3: High Impedance DC pulse input 4-30 VDC (high), Open or 0-1 VDC (low), 10 KΩ imp. 10 kHz max. speed. Accepts simultaneous inputs. May be used with KEP 711 series or PD & D series sensors.

3M: Mag. Input, Input A only, accepts 30mV input (50 V max. P/P) signals 10 KΩ imp. 5 kHz max. (Input B, 4-30V)

3MB: Mag. Input, Inputs A & B, accepts 30mV input (50 V max. P/P) signals 10 KΩ imp. 5 kHz max.

RESET:

Front Panel: Resets displayed value and control output

Remote: 4-30 VDC negative edge resets all counters, "A" counter or "B" counter (user selectable).

K FACTOR/SCALING

The DRT has two separate K-Factors that are used to convert the input pulses to engineering units. The 5 digit K-Factor dividers, with decimal keyed into any position, allow easy direct entry of any K-Factor from 0.0001 to 99999. Separate factors may be entered for the 2 separate input channels.

CONTROL OUTPUTS:

Relays:

2 each N.O. Relay; 10 Amps 120/240 VAC or 28 VDC.

(N.C. relay contacts and NPN transistor output available with solder jumpers. Transistor output is internally pulled up to 10 VDC through relay coil, sinks from 10 VDC to .5 V @ 100 mA)

Analog Output:

An optional 4-20mA (0-20mA) output is available for the DRT. The output can be programmed to track rate or total of the C display. This feature is available by adding suffix A to the part number. Connections are via a 2 terminal pluggable screw connector.

Programming is accomplished by using the front panel in conjunction with rear dip switches.

Accuracy: 50uA worst case.

Compliance Voltage: 3 to 30 VDC non inductive.

Approvals: CSA File# LR91109-7, CE Approved

PRESETS

Two control outputs are provided. To set relay values, press "menu" button until "Relay" appears on the display, the A and B outputs can be assigned to the A, B or C displays. A 5 digit value can be entered for both presets and the decimal point location is the same as the counter. The outputs can be set to energize from 0.1 to 99.9 seconds or latch (0.0). If a value other than 0.0 is entered, the counters will auto reset at the preset (for A&B counters).

LOCKOUT

Unauthorized front panel changes can be prevented by entering a user selected 5 digit code. The front panel can be completely locked out or the presets can remain accessible.

RATEMETER

Accurate to 4 1/2 digits (± 1 display digit). The ratemeter uses 1/tau with 8 digit math, can sample from 2 to 24 seconds maximum, and auto-range up to 5 digits of significant information. In the "RPS" mode, the ratemeter displays in units per second, and in the "scale" mode, units per hour or per minute. The unit will display the rate of the A&B inputs.

COUNTER

The two 5-digit counters can count at 10Khz speed. Each has a separate 5-digit dividing scale factor. The counters advance on the positive edge of each pulse. Besides being able to step through the total and rate values of A & B inputs, the user can

see a selected combination of total and rate of A+B, A-B, A+BX100 (percent of A to B), A+A+BX100 (percent of A to total). The unit can be programmed to view the Total/Rate value of "A+B" & "A-B", or "A+B" & "A+A+B".

RS232/RS422 with KEP Protocol:

If the serial interface option is supplied, up to 99 units can be linked together. (The terminal addressing the unit must be capable of driving all loads in the loop.) Unit status and new set points can be communicated by serial communication. Mode changes, however, must always be made on the front panel. Data is received and transmitted over standard EIA RS232 or RS422 levels. Unit number, baud rate and parity are entered in the "Program Setting" set up mode and remain in memory even if power is off.

RS232/RS422/RS485 with Modbus RTU Protocol:

The serial port can be used for serial printing or also for data acquisition. The unit can address up to 247 units (The terminal addressing the unit must be capable of driving all loads in the loop.) The unit can communicate with a master device through a Modbus-RTU protocol. The data given for each parameter is in IEEE float format comprising of 2 words. The unit can be connected in a network.

- Device ID: 01-247
- Baud Rates: 300, 600, 1200, 2400, 4800, 9600
- Parity: None, Odd, Even
- Protocol: Modbus RTU (Half Duplex)

Mounting:

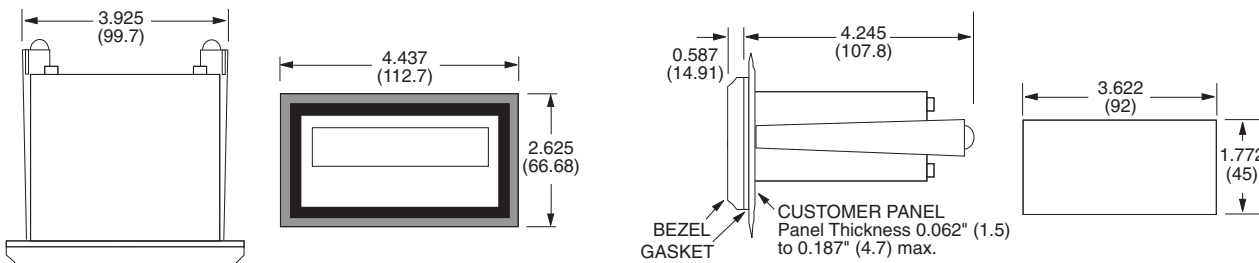

Terminals:

- 1- COMMON
 - 2- N.O.(N.C./NPN)
 - 3- COMMON
 - 4- N.O.(N.C./NPN)
 - 5- A INPUT
 - 6- B INPUT
 - 7- 12VDC OUT/+DC IN
 - 8- -DC (GROUND)
 - 9- RESET INPUT
 - 10- NOT USED
 - 11- A.C. INPUT
 - 12- A.C. INPUT
 - 13- V+
 - 14- I SINK
- RELAYS A B
ANALOG OUTPUT
- | | | |
|---|--------|--------|
| | OFF | ON |
| 1 | RUN | CAL. |
| 2 | 4-20mA | 0-20mA |
| 3 | RATE | COUNT |
| 4 | RUN | SET |
- SWITCH ON

Ordering Information

Example: DRT A 3 1

Series: DRT= 6 digits, counter / ratemeter with presets and scaling.

Operating Voltage: A= 110 VAC \pm 15% or 12 to 15 VDC
B= 220 VAC \pm 15% or 12 to 15 VDC
C= 24 VAC \pm 15% or 12 to 15 VDC

Count Inputs: 3 = Standard, 4-30 VDC simultaneous inputs.
3M = Mag. Input, Input A only, 30mV input (Input B, 4-30V)
3MB = Mag. Input, Inputs A & B, 30mV input

Options: (Multiple Options Not Available) A= Analog Output (4-20/0-20 mA)
1= RS232 Communications
2= RS422 Communications
3= Modbus RTU RS232
4= Modbus RTU RS422/RS485

Accessories:

- Separate non keyboard panel order #34235
- Separate keyboard panel - order #34234

RTP

Two Separate Ratemeters, Totalizers With 2-Line LCD Display

Features

- Two pulse and three control inputs
- Displays: A Rate, A Total, B Rate, B Total, A+B Rate, A+B Total, A-B Rate, A-B Total, Grand Total
- Separate Scaling Factors For A & B Inputs
- Two relay outputs with LED Indication
- RS232/ RS485 port for serial communication and printing
- Security lockout
- 4-20 mA output (optional)

DESCRIPTION:

The RTP is a presettable Ratemeter and Totalizer from two pulse inputs. It can show rate and total at the same time on the 2 X 16 backlit LCD display. Both inputs can have up to 16 point linearizing k factors. The unit can be connected in a network for Data Acquisition.

SPECIFICATIONS:

INPUT POWER:	AC: 85 to 265 VAC; 6.5 VA DC: +24 VDC ; 250 mA max.
THRESHOLD:	High: 4-24 VDC; Low: < 1Vdc or open
INPUT A:	Count Input, 5 kHz max.
INPUT B:	Count Input, 5 kHz max.
INPUT C:	Control Input
INPUT D:	Control Input
INPUT E:	Control Input (Not Used with RS485)
MAG INPUT(3MB):	Inputs A & B, accepts 30mV input (30 V max. P/P) signals 10 K Ω imp. 5 kHz max.
NOTE:	AC powered units have isolated inputs. DC units share -DC with input common.
OUTPUT POWER:	+20VDC @50 mA (unreg), +/- 15%
DISPLAY:	2 lines of 16 characters, backlit LCD (character size: 2.95mm x 5.55mm)
BEZEL:	NEMA 4/IP65 rated membrane keypad
INDICATORS:	Two LED's to indicate control output status. (Red = Output A, Green = Output B)
MEMORY:	NVRAM retains data on power failure
TEMPERATURE:	Operating : 0 to 50 degrees C Storage : -40 to 90 degrees C
HUMIDITY:	10% to 90% (Non condensing)
SIZE:	Bezel: 103mm X 55 mm; Depth:97 mm
PANEL CUTOUT:	92 mm X 45 mm (1/8 DIN size cutout)
IMMUNITY TO ESD:	Level 3 per IEC1000-4-2
IMMUNITY TO TRANSIENTS:	Level 3 per IEC1000-4-4
RADIATED SUSCEPTIBILITY:	Level 3 per IEC1000-4-3
EMISSIONS:	EN55011 CISPR A



- NVRAM to retain data on power failure
- NEMA 4 / IP65 Front Panel

PULSE INPUTS

The RTP can accept two pulse inputs (A&B). It computes rate and total of A, B, A+B and A-B. For both inputs the user can define up to 16 points of "k" factors. This allows linearization of the displayed rate, which is useful in improving the accuracy of the flowmeter.

The rate is computed within 300 ms per input. To stabilize the rate display, the user can select normalizing factor, which allows weighted average to be shown. Moreover, for rate displays, a time delay of up to 25 seconds can also be selected.

CONTROL INPUTS

The RTP has three Control Inputs, i.e. Input C, Input D and Input E (Only C & D with RS485 option). Each input can be configured to start/stop each counter or reset each counter and Control Output. These inputs can also perform different control actions like printing on serial port, lock unit and freeze display.

RESET OPTIONS

The entire unit, i.e. all counters and control outputs, or Counter A, Counter B, Counter A+B, Counter A-B, Control O/P A and Control O/P B can be individually programmed to be reset on pressing the front panel RST key and also by a positive edge signal to any of the Control I/Ps C, D and E.

SERIAL COMMUNICATION

The serial strobed port can be used for serial printing of Total or Rate data with descriptors. The unit can also communicate with a master device through a Modbus-RTU protocol. The data given for each parameter is in IEEE float format comprising of 2 words. The unit can be connected in a network. Order Option 1 is RS-232 level format; Order Option 2 is RS-422/485 level format.

CONTROL OUTPUTS

RELAY: 2 N.O. relays of 5 A and 250 V

ANALOG OUTPUT:

Type: 4-20 mA output.
Accuracy: ± 50µA worst case.

This Analog O/P can be programmed to track any parameter. Reverse tracking O/P is also available.

PRESETS: The unit supports five counters, i.e. Counter A, Counter B, Counter A+B, Counter A-B and Grand Total. The counters can either be reset to zero or disabled. Relays can be activated by any of the Total or Rate values. If a Total preset activates the relay, the user can select an output duration of 0.1 to 99.9 seconds with instant auto reset to "0". A 00.0 duration keeps the relay activated until externally

reset. If both presets are assigned to same counter, with Relay A duration set to 00.0 and Preset A lower than Preset B, Relay A pulls in at Preset A and drops out when Preset B (having a duration other than 00.0) pulls in. Counter recycles immediately, and Relay B stays activated for the selected duration.

If activated by rate, the relay pulls in at High Preset or above and remains on until rate falls below Low Preset.

LOCKOUT: The unit program and presets can be protected with a lock code to prevent unauthorized front panel changes. This code can be assigned with a maximum of 4 digits and is user selectable. It can be entered through front panel LOCK key or by configuring any of the Control I/Ps to "Lock unit". Alternate entry of the lock code or pulses to that I/P will lock or unlock the unit.

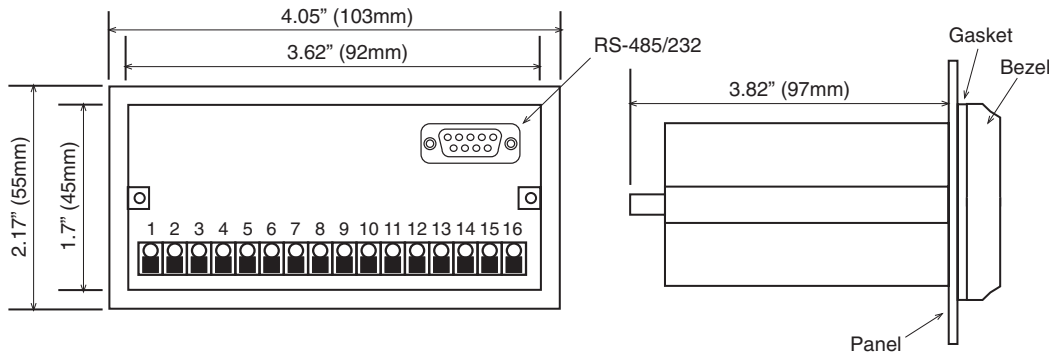

Terminal Designations:

AC POWER

- 1 • AC1 (85 TO 265VAC)
- 2 • AC2 (85 TO 265VAC)
- 3 • RELAY B
- 4 • COMMON
- 5 • RELAY A
- 6 • COMMON
- 7 • (+) 20VDC OUT (50mA)
- 8 • (-) 20VDC OUT (50mA)
- 9 • ANALOG O/P (+)
- 10 • ANALOG O/P (-)
- 11 • CTRL I/P E
- 12 • CTRL I/P D
- 13 • CTRL I/P C
- 14 • PULSE I/P B
- 15 • PULSE I/P A
- 16 • INPUT GND

DC POWER

- 1 • (+) 24 VDC POWER
- 2 • (-) 24 VDC POWER
- 3 • RELAY B
- 4 • COMMON
- 5 • RELAY A
- 6 • COMMON
- 7 • NOT USED
- 8 • NOT USED
- 9 • ANALOG O/P (+)
- 10 • ANALOG O/P (-)
- 11 • CTRL I/P E
- 12 • CTRL I/P D
- 13 • CTRL I/P C
- 14 • PULSE I/P B
- 15 • PULSE I/P A
- 16 • INPUT GND

Communication Port Terminal Designations:



- 1 • Transmit B (-)
- 2 • Receive B (-)
- 3 • N.C.
- 4 • N.C.
- 5 • Ground
- 6 • N.C.
- 7 • N.C.
- 8 • Receive A (+)
- 9 • Transmit A (+)

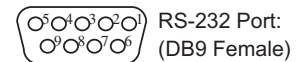

- 1 • N.C.
- 2 • Transmit
- 3 • Receive
- 4 • N.C.
- 5 • Ground
- 6 • Strobe
- 7 • N.C.
- 8 • N.C.
- 9 • N.C.

Ordering Information

Example: RTP A 3 1

Series: RTP= Pulse Input Ratemeter/Totalizer

Operating Voltage:
A= 110 VAC ± 15%
B= 220 VAC ± 15%
C= 24 VDC

Input:
3= Standard, 4-30 VDC simultaneous inputs
3MB= Mag. Input, inputs A & B 30mV input (24VDC Powerd units only)

Options:
1= RS-232, 3 Control Inputs (not available with RS-485)
2= RS-485/Modbus-RTU, 2 Control Inputs (not available with RS-232)
A= 4-20 mA Out (Can be ordered with options 1 or 2)

Accessories
NEMA 4X wall mount enclosure available, see NEMA-1/8DIN
XHV 7/4 Explosion Proof Housing available, see XHV7/4

KEYPAD FUNCTIONS		
KEY	Run Mode	Program Mode
PROG	Enter The Programming Mode	Toggles between menus
VIEW	VIEW key scrolls through the selected viewing parameters	Left key shifts digits in number entry/characters in message mode
PRE A	PRE A key allows Preset A to be changed if unit is not locked	Up key increments digits/characters
CLR PRE B	PRE B key allows Preset B to be changed if unit is not locked	CLR key clears the numeric field
ENT LOCK	Lock Key allows the entry of a lock code to lock/unlock the unit	ENT key saves changes and steps to next menu
RST	RST Key resets counters (with/without confirmation)	Unit comes out of programming at any level

INTELLECT-69

Ratemeter / Totalizer From Analog Inputs

Features

- High/Low Scaling From Front Panel
- 2 Set Points Assignable To Rate Or Total
- Display Rate (pressure, level, watts, etc.), Peak & Valley and Integrated Total
- 0-5V, 0-10V, 1-5V, 4-20mA or 0-20mA Analog Input
- NEMA 4X/IP 65 Front Panel
- +24V Output For Peripherals
- RS422/232 Serial Communications
- 4-20mA Output
- Square Root Extraction

Description:

The Intellect-69 is an integrating totalizer/ratemeter which accepts analog signal inputs. The unit can be field programmed to accept 4-20mA, 0-20mA, 0-5V, 0-10V or 1-5V signals. An optional Square Law input is available for inputs that require square root extraction. A 4-20mA output option is available to control strip recorders or other peripherals. Two assignable set points are standard for two stage shut off. The high and low scaling settings are programmable from the front panel. By pressing the "view" button, the unit will display: integrated total, rate, peak or valley. Press the "lock" key once to freeze the display. RS422 or RS232 serial communications are available options for data communication with a host computer.

Specifications:

Display: 6 digit, .55" high, 7 segment, red orange, LED.

Input Power: 110, 220 VAC $\pm 15\%$ or 12 to 24VDC.

Current: max. 300 mA DC or 10.0 VA at rated AC voltage.

Output Power: (AC powered units only) + 24VDC @ 50mA regulated $\pm 5\%$

Temperature:

Operating: +41°F (5°C) to +130°F (+54°C).

Storage: -40°F (-40°C) to +200°F (93°C).

Humidity: 0-90% Noncondensing

Memory: EEPROM stores data for 10 years if power is lost.

Reset:

Front Panel: resets displayed values and control outputs.

Remote: 4-30VDC positive edge, resets totalizer and control outputs.

Input:

Standard: Linear 4-20mA, 0-20mA, 0-5V, 0-10V or 1-5V selectable from the front panel.

Optional: Square Law 4-20mA, 0-20mA, 0-5V, 0-10V or 1-5V is available for inputs that require square root extraction.



Input Impedance: Current: 100 Ω ; Voltage: 115K Ω

Overvoltage Protection: 50 V

Overcurrent Protection: 50 mA

Resolution: 14.5 Bits

Approvals: CE Approved, CSA (File No. LR91109),

Calibration: The unit does all of the calibrations internally. There are no potentiometers to adjust and the unit never needs to be removed from the case.

Control Outputs:

Standard: Open collector sinks 250mA from 30VDC when active.

Optional: 2 each Form C SPDT 5 Amp @ 120/240 VAC or 28 VDC. (Open collector outputs are also supplied with 10VDC provided at transistor outputs through relay coil. If greater than 2mA is used, relay will remain energized. Applying greater than 10 VDC may destroy unit. Transistor will sink 100mA in "ON" state.)

Set Points: Two control set points are provided. The set point outputs can be assigned to rate or total. The unit comes standard with two open collector control outputs. Two 5 Amp, Form C relays are optional. The outputs are programmable from .01 to 599.99 sec or latched until reset when assigned to the total and a hysteresis (alarm range) when assigned to the rate.

Rate Display: Updates 5 times per second, Accurate to 4.5 digits. Set "low" greater than "high" for inverted display (LINEAR ONLY). A user programmable low cutoff inhibits indications at low flow rates.

Totalizer: Integrates from the rate reading and accumulates up to 6 digits of total count. A totalizer divider allows the total to be divided by 1, 10, 100 or 1000. This feature is especially useful for users who deal with high total volumes.

Analog Output: The unit can be ordered with an optional 4-20mA output which is proportional to the rate display. The high and low settings are programmable from the front panel. Set "low" greater than "high" for inverted output. A sinking driver generates a corresponding linear current through the external devices. The output updates with each update of the rate. Accuracy is $\pm .25\%$ FS worst case. Compliance voltage must be 3 to 30 VDC non inductive. (The unit can provide the DC source as long as the drop across the devices being driven does not exceed 21V).

Programming: Decimal points, Scaling from 0 to 59999 units per selected time base, set points, input type, security lock code, and assigning outputs are all programmable from the front panel.

Housing: Standard 1/8 DIN, high impact ABS plastic case (NEMA 4X/IP65 front panel).

Shipping Weight: 2 lbs.

Accuracy:

RANGE	% FS ERROR (worst case)	% FS ERROR (typical)
0-20 mA	0.1%	.05%
4-20 mA	0.1%	.05%
0-10 VDC	0.2%	0.1%
0-5 VDC	.25%	.15%
1-5 VDC	.25%	.15%

Square Law: (above 5% of bottom range) 0.1%
(5V inputs .4%) Worst case over complete range: 2%

Temperature Stability: Will not drift more than 20 parts per million per °C from 5°C to 54°C

WIRING:

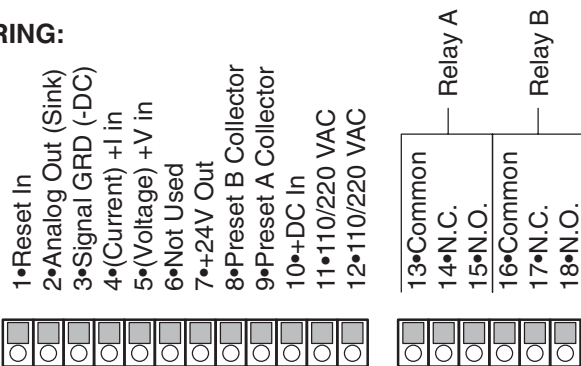

Dimensions:

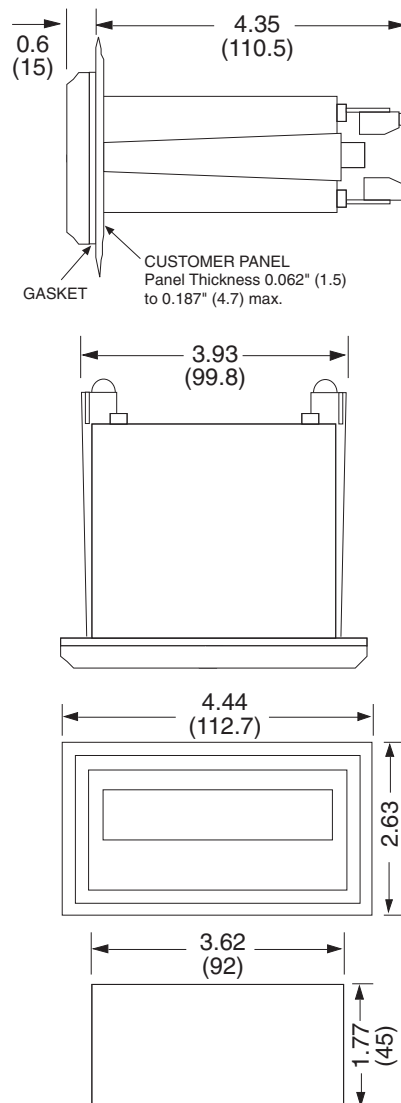

2-Wire 4-20mA Transmitter

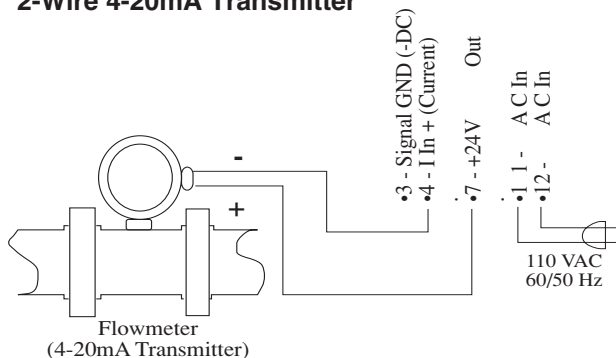

3-Wire 0-10V Transmitter

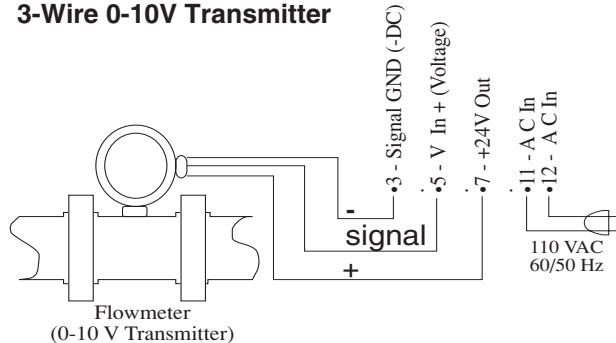

Ordering Information

Example: INT69RT A L 1 A C1

Series: INT69RT= Ratemeter / Totalizer
INT69R= Ratemeter Only
INT69T= Totalizer Only

Operating Voltage: A= 110 VAC ± 15% or 12 to 24 VDC
B= 220 VAC ± 15% or 12 to 24 VDC

Inputs: L= Linear (standard)
S= Square Law (optional)

Control outputs: 1= 2 - Open Collector Outputs (standard)
2= 2 - 10 Amp Form C Relays (optional)

Options (Multiple Options Available)
A= Analog Output (4-20 mA)
D= Rate per Day, Hour or Minute
C1= RS 232 communications
C2= RS 422 communications
CSA= CSA Approved Unit (pending) (consult factory)

Accessories
XHV - Explosion proof housing (see accessories section)
NEMA-1/8DIN- NEMA 4X enclosure (see accessories section)
Separate non keyboard panel order #34235
Separate keyboard panel - order #34234

PMT-555 Series

Process Monitor and Totalizer from Analog Inputs

Features

- Large keys allow easy operation and programming
- Display Hold or reset input for the totalizer or for the limit values
- Key lock input
- Programmable 24 point linearization
- Integration function (totalizer) for the integration (sum calculation) of the measured values (e.g. throughput measurement => Fill-up level) with own scaling and programmable input threshold
- RS-232, RS-422, RS-485 Option
- Current or voltage input



COUNTERS/RATEMETERS

- 2 setpoints with programmable hysteresis and 2 relays or optocoupler outputs
- 10 VDC and/or 24 VDC output power supply

Description:

The PMT-555 process monitor/totalizer is ideal for applications that require an LED process/totalizer display from voltage or current inputs. The unit can accept 4-20mA, 0-20mA, 0-10V, 2-10V or -10 - +10V signals. Two assignable set points are standard.

Specifications:

Supply voltage:	10 to 30 V DC, galvanically isolated with reverse polarity protection 90 to 260 V AC 50/60 Hz mains hum suppression	Current input:	0-20 mA, 4- 20 mA voltage drop max. 2 V limit 50 mA
Power consumption:	max. 2 W/6 VA	Voltage input:	0-10 V, 2-10 V, (-)10 - (+)10 V limit ± 30 V input resistance > 1 M Ω
Display:	5-digit , red 7-segment LED's height 14 mm	Control inputs:	High: 4-30 V DC Low: 0-2 V DC
Measuring rate:	1 measurement/second	Resolution:	14 bits
Data backup:	EEPROM	Accuracy:	< 0.1 % ± 1 digit at 20 °C, automatic null balance
Housing:	housing for control panel 96 x 48 mm acc. to DIN 43 700; RAL 7021, dark grey	DC output:	10 V DC $\pm 2\%$, 30 mA(DC powered units) 10 V DC $\pm 2\%$, 30 mA and 24 V DC $\pm 15\%$, 50 mA (AC powered units)
Ambient temperature:	-10 to +50°C	Outputs:	2 Form C Relays max. 300 V DC/250 V AC current: max. 3 A, min. 30 mA DC or optocoupler output, NPN 30 V, 15 mA
EMC:	according to EC EMC directive 89/36/EEC		
Interference emissions:	EN 50081-2/EN 55 011 Class B		
Interference resistance:	EN 6100-6-2		
Protection:	IP65 (front)		
Weight:	app. 190 g		

Wiring Connections

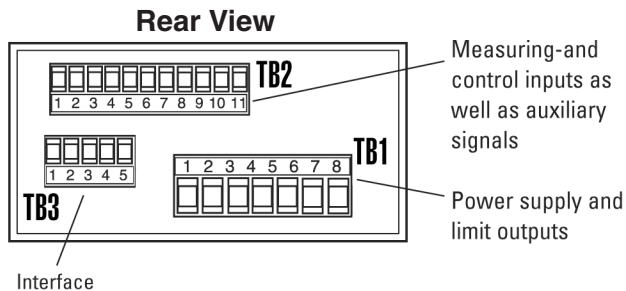

TB1 Measurement Inputs

Pin	Description	Pin	Description
1	Current input 0 ... 20 mA, 4 ... 20 mA	7	Reference ground control inputs
2	Analog GND	8	Display-Hold/Reset input
3	Voltage input 0 ... 10 V, 2 ... 10 V -10 ... 10 V	9	Auxiliary voltage GND
4	n.c.	10	+10 V DC, 30 mA auxiliary voltage
5	n.c.	11	+24 V DC, 50 mA auxiliary voltage only for AC version
6	"Key" key lock		

TB2 Supply Voltage and Outputs

Pin	Relays output	Optocoupler Output (PNP)	Output
1	common (C)	Emitter	2
2	norm. open (NO)	Collector	
3	norm. closed (NC)	Collector	
4	common (C)	Emitter	1
5	norm. open (NO)	n.c.	
6	norm. closed (NC)	Collector	

Pin	DC version	AC version
7	10 ... 30 V DC	90 ... 260 V AC
8	0 V DC (GND)	90 ... 260 V AC

TB3 Serial Interface

	RS232	RS485	RS422
1	GND	-	-
2	RxD	DO+/RI+	RI+
3	TxD	DO-/RI-	RI-
4	-	-	DO+
5	-	-	DO-

Dimensions

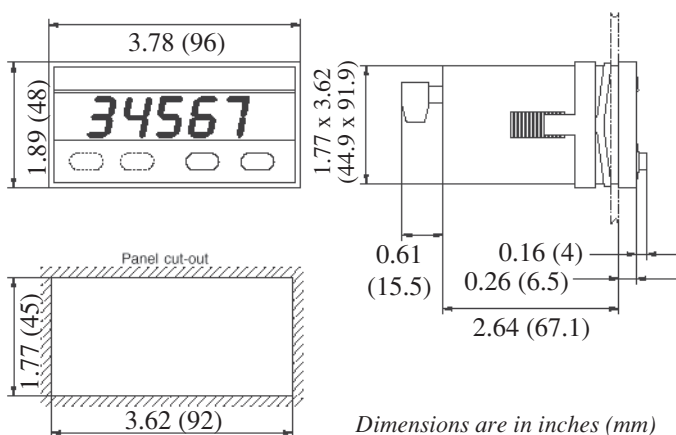

Order Code

Example: **PMT555.01 0 00**

Series: _____

PMT-555 = Process Monitor & Totalizer
w/ 2 Presets/Relays

Operating Voltage: _____

0 = 90 to 260 VAC
3 = 10 to 30 VDC

Options: _____

00 = without interface
05 = RS232
06 = RS422
07 = RS485

HK17

Miniature Time Meter

Features

- Interchangeable with "Hobbs Minimeter"
- Low Cost
- 5 Hour Digits, .150" High, White on Black and Two Decimal Digits Red on Black
- Operation Indicator Wheel
- DC Accuracy = .05%
- Power Required = .2 Watt (DC), 2VA (AC)
- Temperature: -15°C to 50° C (5° F to 122° F)
- NEMA 4X/IP65 Sealed Front

Applications:

A high reliability instrument perfect for recording the operating time for maintenance, testing, leasing and warranty programs on all types of machinery.

Description:

Small in size and price, but rugged and durable, this AC or DC powered hour timer is driven by a synchronous motor. Many voltages are available. Four industry standard mounting styles are available. The unit is provided with easy connect, screw terminal connectors on .031" x .250" flat pins. This minimeter is especially designed for use on lighting systems, computers, business machines, control panels, generators, compressors and pumps. Useful also for service records on machinery such as industrial refrigerators, oxygen purifiers, printers or off-road vehicles.

Specifications:

Digit Size: 0.150" x .067" (3.8 x 1.7)

Display:

Hours: white digits on black

Decimals: red digits on black

Voltages:

24, 110, 220 VAC ± 10% 50 or 60 Hz

12 to 24, 36 to 80, 110 VDC ± 15%

Power Consumption:

Approx 2 VA at 230 VAC

Approx. .2 Watts at 12 VDC

Termination: Flat tabs .031 x .250" with screw terminal.

Reset: None



HK17.00



HK17.10



HK17.20

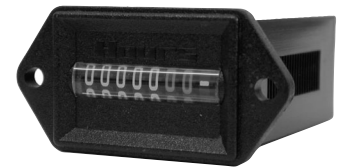

HK17.40

Drive:

Synchronous motor with AC

Stepping motor with DC

Operation Indicator:

AC: Fast rotating wheel with red stripes

DC: 1/100 h-display rotates every 36 sec. by one number.

Temperature: - 15°C to + 50°C (+5°F to + 122°F)

Housing: NEMA 4X(IP65) front panel (gasket not supplied, RTV type sealer recommended), plastic case

Weight: 1.4 ounces (40 g)

Approvals: CE Approved, UL Listed; File# E128604

How To Order

EXAMPLE: HK17 4 0 110V 60 1

Series	HK17				
Case	4	0	110V	60	1
	0 = Rear mount				
	1 = Screw mount				
	2 = Spring clip				
	4 = Side flange				
	5 = Large spring clip				
	6 = Large side flange				
Reset	0				
	0 = Non reset				
Operating Voltage	12VDC				
	(12 to 24 VDC)				
	36VDC				
	(36 to 80 VDC)				
	110VDC				
	(110 VDC ± 15%)				
	24V 60				
	(50 for 50Hz) (AC Voltages ±10%)				
	110V 60				
	(50 for 50Hz) (AC Voltages ±10%)				
	220V 60				
	(50 for 50Hz) (AC Voltages ±10%)				
Options	1				
	1 = .031" x .250" tab without screw terminal				
	2 = Case sealed in back				

Mounting:

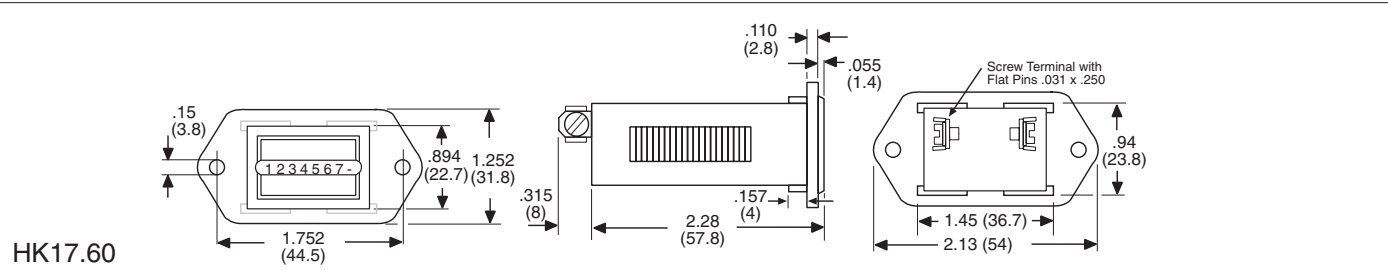
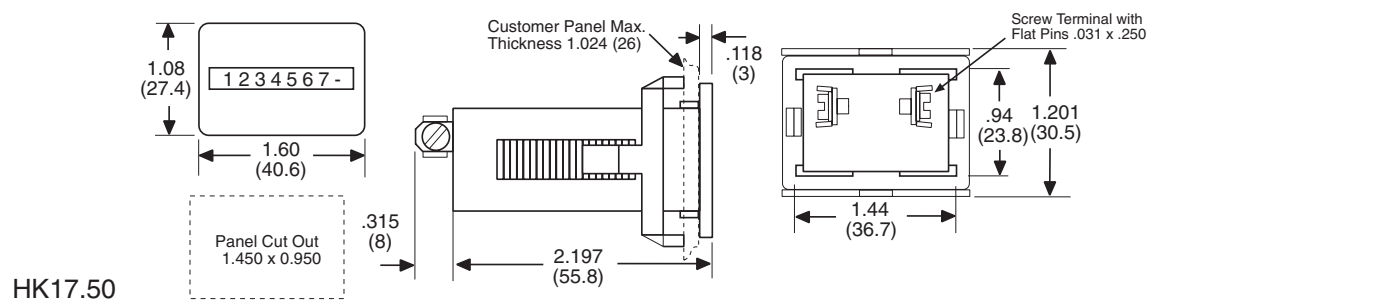
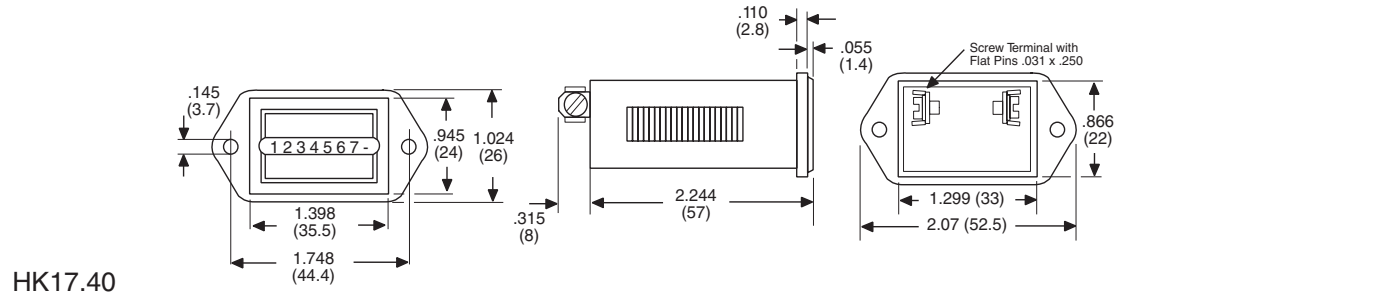
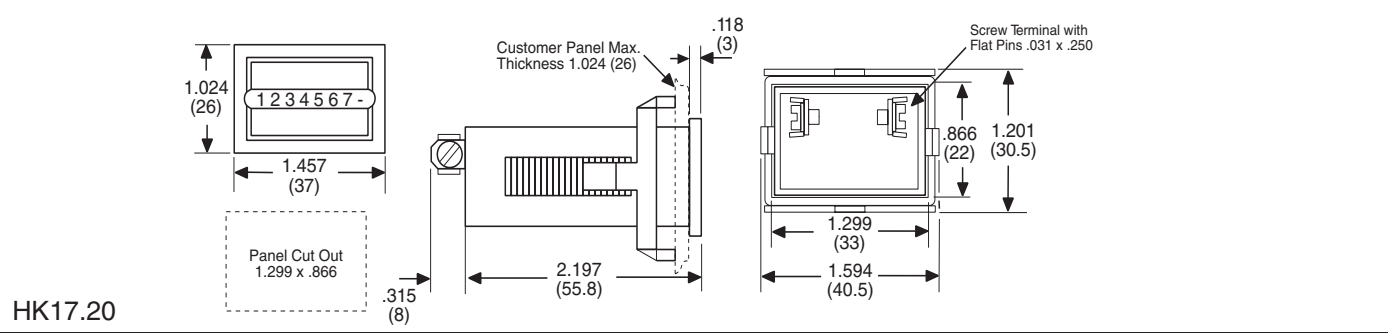
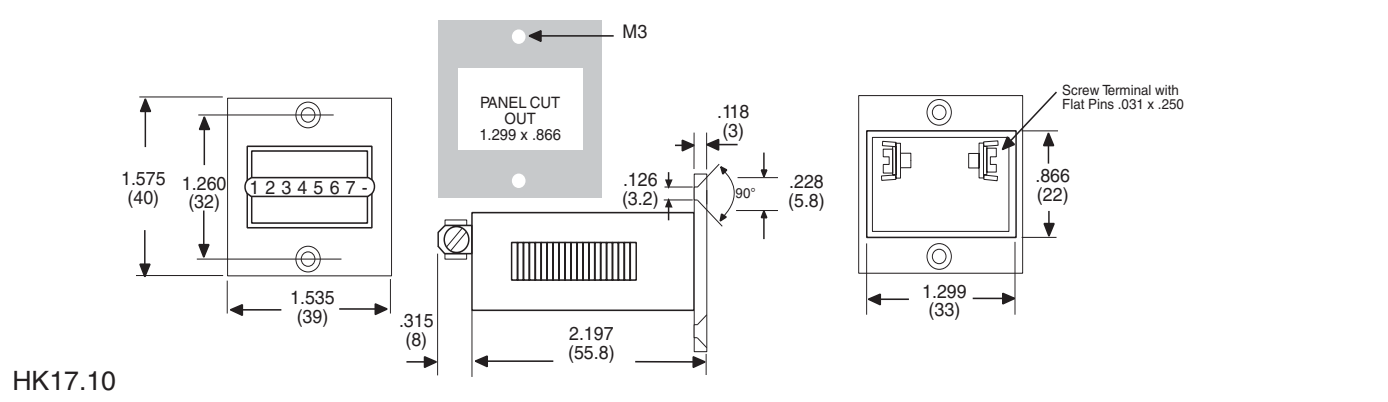
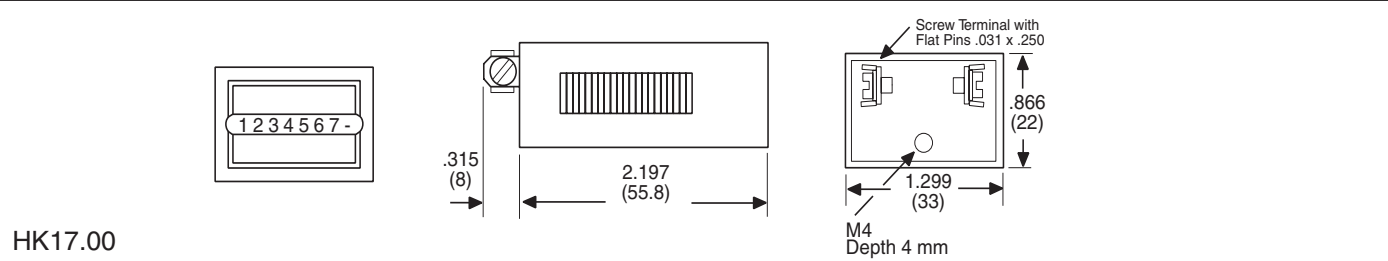

HK07

Miniature Hour Meters

Features

- Super Low Power
- Hours & 1 /100th Resolution
- 7 Digits with Magnifying Lens .16" (without magnifying lens .11 ")
- 7 Mounting Styles, Including PCB Mount Models
- Tiny Size

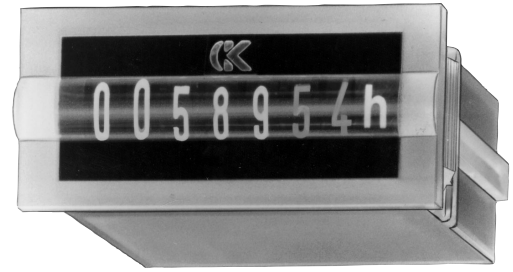

Applications:

Printed circuit board warranty. Warranty monitoring where low power consumption is required, usually in battery operated devices.

Description:

The HK Series hour meters use a quartz crystal oscillator that generates an impulse every 36 seconds or 0.01 of an hour. The coil is triggered for 32 ms. Max power consumption is needed only after every 36s. The rest of the time the power consumption is max. 2mA. This allows battery operation and use on electronic PC Boards. On times less than 36s are not counted. A very high shock resistance guarantees accurate timing under abnormal conditions.

Specifications:

PCB Mount Models: silver-plated solder pins 0.016" x 0.047"

Display: 99999.99 H

Digits: Hours, white on black; Decimals, red on black

Rated voltage: 5,12, 24VDC $\pm 10\%$

Residual ripple: max. 5%

Average power consumption: approx. 10 mW on 5VDC; approx. 24 mW on 12VDC; approx. 48 mW on 24VDC.

Max. power consumption: every 36s with an impulse length of 32ms approx. 55mW on 5VDC; approx. 120 mW on 12VDC; approx. 250 mW on 24VDC

Ambient temperature: +14° F to +185° F (-10°C to +85°C).

Solderable and wash proof versions:

HK 07.90, HK 07.91 and HK 07.92

Electric Connections on flush and base mount models:

approx. 6" long wire leads (red +); (black -)

Accuracy: .005%

Approvals: CE Approved

AVAILABLE TYPES TYPE	HEIGHT OF HOUSING	FIGURES	ELEC. DISPLAY	CONNECTION	VOLTAGE $\pm 10\%$ DESCRIPTION (Specify)
HK 07.20 plastic	.16"	on narrow side	flying leads	flush mount / snap-in	5, 12, 24 VDC
HK 07.40 steel Sheet	.16"	on broad side	solder pins	PCB-mount	5, 12, 24 VDC
HK 07.50 steel sheet	.16"	on narrow side	solder pins	PCB-mount	5, 12, 24 VDC
HK 07.80 plastic	.16"	on narrow side	solder pins	PCB-mount	5, 12, 24 VDC
HK 07.90 plastic	.16"	on broad side	solder pins	PCB-mount-wash proof	5, 12, 24 VDC
HK 07.91 plastic	.11"	on narrow side	solder pins	PCB-mount-wash proof	5, 12, 24 VDC
HK 07.92 plastic	.16"	on narrow side	solder pins	PCB-mount-wash proof	5, 12, 24 VDC
AHK 07.00 plastic	.16"	on narrow side	flying leads	base mount	5, 12, 24 VDC

Dimensional Diagrams:

TIMERS

HK07.20

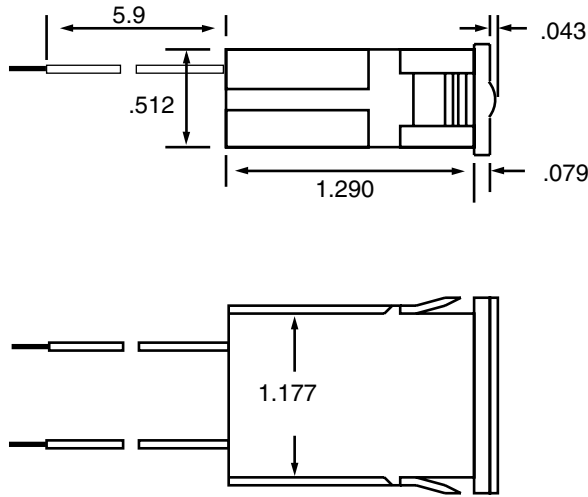
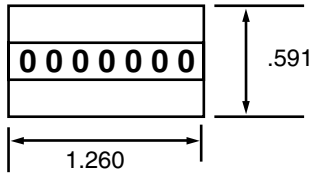

Panel Cutout

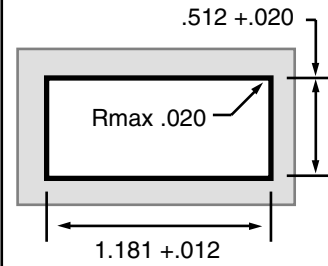

**MAG. LENS
HK07.40**

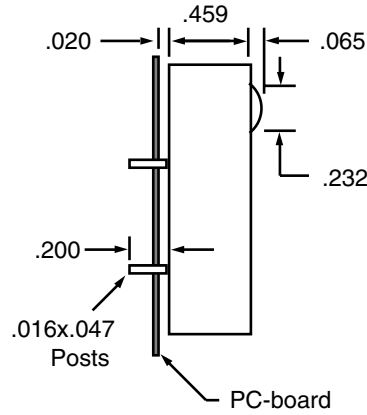
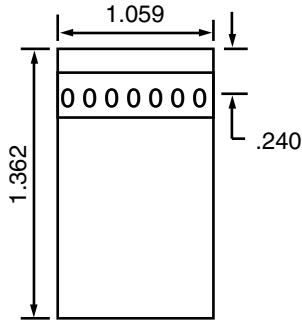

**Punching diagram for PCB
(component side)**

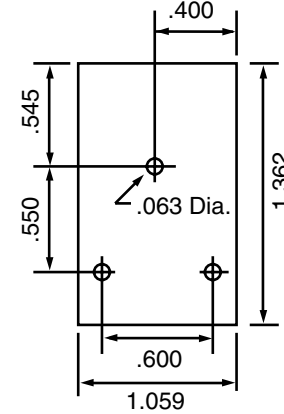

**MAG. LENS
HK07.50
HK07.91**

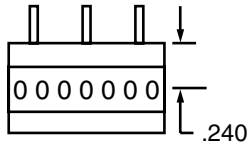

AHK07.00

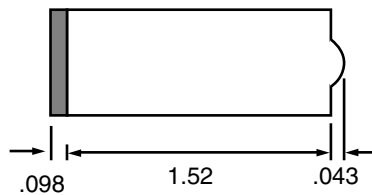
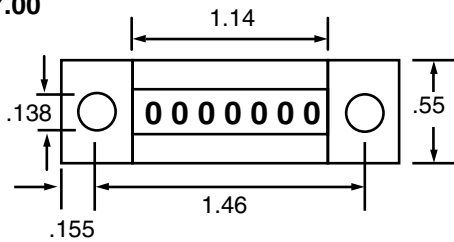

**HK07.80
(HK07.92)**

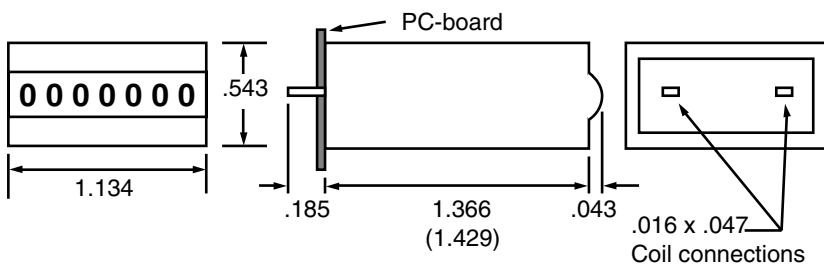

**Punching diagram for PCB
(component side)**

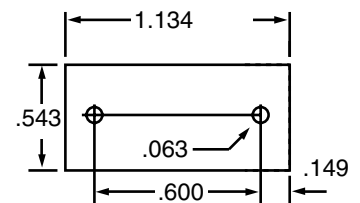

H57

Low Cost Hour Meter

Features

- UL Listed, CE Certified
- Low Cost
- 7 Digit Display (99999.99 Hours)
- AC or DC Voltages
- Small Case

Description:

These meters are mainly used for monitoring the running time of machines, apparatus and instruments as well as for recording maintenance time, warranty time or rental use time. A synchronous motor operating through a gear train drives the number wheels for the display of full hours 1/10 h and 1/100 h. On AC-versions, the main supply (50 or 60 Hz) is used as frequency standard. On DC-versions the exact frequency generated by means of a quartz crystal. A rugged and completely insulated plastic housing provides substantial protection against environmental influences.

Specifications:

Termination: Flat tabs .031 x .250" with screw terminal
Voltages: 24, 110, 220, 440 VAC +15%, 50 Hz or 60Hz
 12 to 24, 36 to 80, 110 VDC ± 10 %
Test Voltage: 2000V, 50 Hz
Ambient temperature:
 -15° to +50°C on AC; -20° to +60°C on DC
Power Consumption:
 Appr. 2 VA at 220 VAC; Appr. 180 mW at 12 VDC
Hour range: AC Units: 99999.99 hours
 DC Units: 999999.99 hours

Height of Figures: 4 mm

Color of Figures:

Hours: white on black, Decimals: red on black

Color of Housing: Black

Operation indicator: Fast rotating, white

Approvals: UL Listed: File # E128604X, CE Approved

Weight: AH57: 84g; H57 48g

How To Order:

EXAMPLE:	H57	24VAC	60Hz
Series	H57 = Panel Mount AH57 = Base Mount H57.55 = Extended 2.16" x 2.16" Bezel for 2" diameter cutout H57.72 = Extended 2.83" x 2.83" Bezel for 2" diameter cutout		
Voltages	12, 24, 36, 80, 110 VDC 24, 40, 110, 220, 440 VAC		
Frequency (AC units only)	50 or 60Hz (Specify)		
Accessories	DR-4 = 4 DIN Rail (DIN 46277)		



Dimensions:

H57 (Panel Mount)

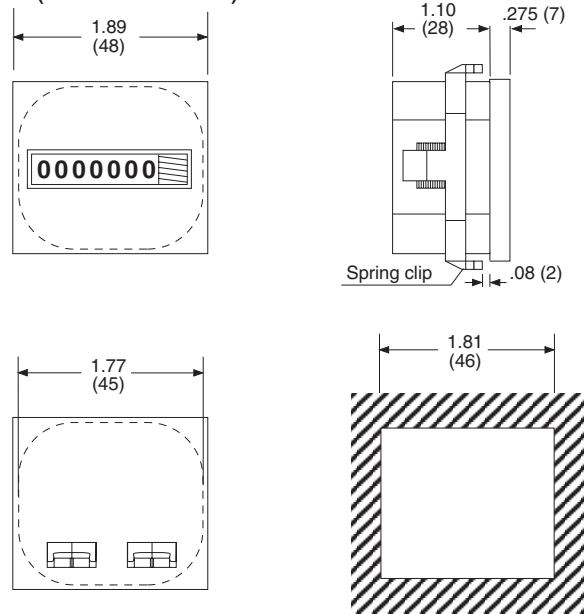

AH57 (Base Mount) & DIN Rail Mount

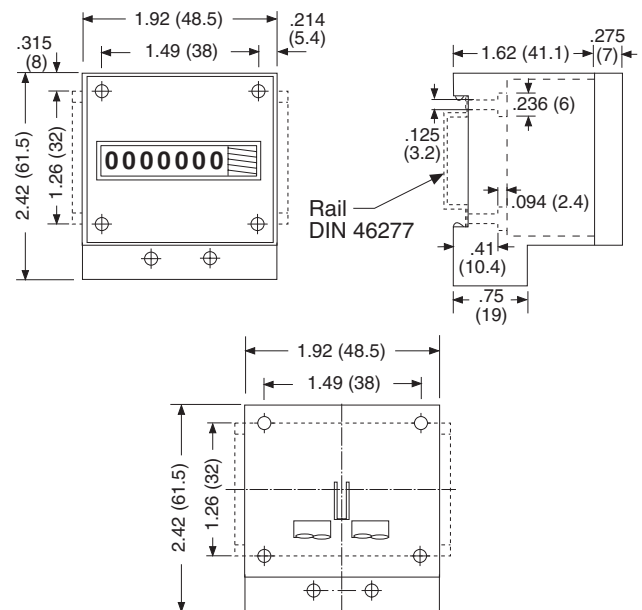

HC77

Combination Hour Meter & Totalizer

Features

- Dual 7 digit display w/characters magnified to .157" (4mm)
- Low Cost
- Isolation protection to VDEO435.
- AC or DC Voltages



TIMERS

Description:

This combination meter comprises a running time totalizer and an adding counter with a separate 7 digit display for each. In the standard version, the two meters are connected in parallel; the totalizer counts the number of pulses while the time meter totalizes the connect time. The time meter displays to hundredths of an hour (36 second intervals). A red visual indicator shows that the unit is operating. The unit is supplied with a clamp clip attachment for mounting and 2.16" x 2.16" (55mm) and 2.16" x 2.16" (72 x 72 mm) bezels are available as accessories. On AC models, the main supply (50 or 60 Hz) is used as the frequency standard. On DC models, the frequency is quartz crystal controlled.

Applications:

- Heating and utility system monitoring
- Machine run time monitoring and maintenance
- Refrigeration systems
- Water treatment equipment
- Compressors
- Industrial washing equipment

Specifications:

Termination: Flat tabs .031 x .250" with screw terminal

Voltages: 24, 110, 220 VAC +15%, 50 Hz or 60 Hz
12 to 24, 36 to 80, 110 VDC ± 10 %

Power Consumption:

Appr. 2.5 VA at 220 VAC; Appr. 220 mW at 12 VDC

Ambient temperature:

-15° to +50°C on AC; -20° to +60°C on DC

Environmental Protection: IP42, DIN 40 050 from front

Hour range: AC Units: 99999.99 hours
DC Units: 999999.99 hours

Count range: 9999999 counts

Display: Dual display with characters magnified to 0.157" (4mm) high.

Color of Figures:

White on black for hours, red on white for decimal hours
White on black for totalizing counter.

Color of Housing: Black

Operation indicator: Fast rotating, red

Weight: 2.3 Oz. (65g)

Approvals: CE Approved, UL Listed; File# E128604

Dimensions:

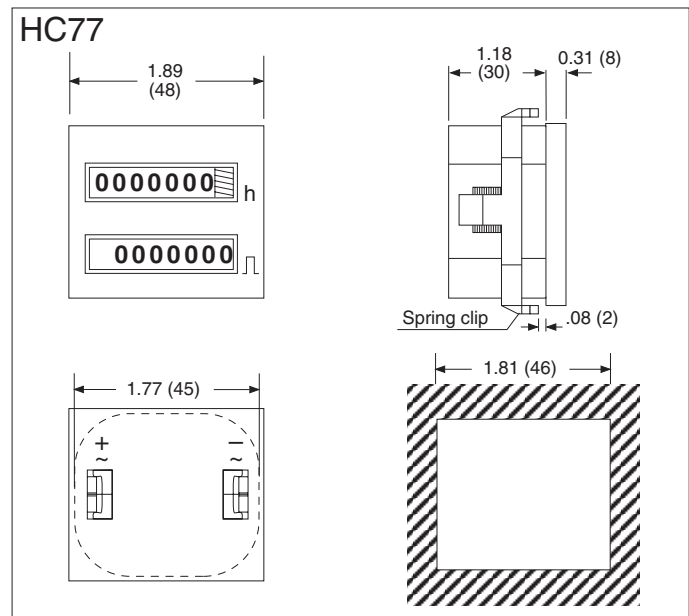

How To Order:

EXAMPLE:	HC77	24VAC	60Hz	SC
Series	HC77 = Panel Mount HC77.55 = Extended 2.16" x 2.16" Bezel for 2" diameter cutout HC77.72 = Extended 2.83" x 2.83" Bezel for 2" diameter cutout			
Voltages	12VDC (12 to 24 VDC) 36VDC (36 to 80 VDC) 110VDC (110 VDC ± 15%) 24V (AC Voltages ±10%) 110V (AC Voltages ±10%) 220V (AC Voltages ±10%)			
Frequency (AC units only)	50 or 60Hz (Specify)			
Options:	SC = Separate Connections			

HC67

Combination Hour Meter & Totalizer

Features

- Dual 7 digit display w/characters magnified to 0.157" (4mm)
- Synchronous Motor Drive
- Isolation protection to VDEO435.
- AC Voltages

Description:

This combination counter consists of a running time meter and an adding counter. These two meters are connected in parallel, the adding counter registering the total number of events and the time meter the total operating time of the device. Due to high shock resistance, a reliable count is guaranteed.

Applications:

- Heating and utility system monitoring
- Machine run time monitoring and maintenance
- Refrigeration systems
- Water treatment equipment
- Compressors
- Industrial washing equipment

Hour Meter:

Counting range: 99999.99 h

The coil of an impulse counter receives a drive pulse from a divider circuit every 36 seconds = 0.1h (quartz accuracy). On-times < 36 s are not counted.

Adding Counter: Counting range: 9999999 pulses.

Specifications:

Termination: Flat tabs .031 x .250"

Voltages: 110, 220 VAC +10%, 50 Hz or 60 Hz

Power Consumption: Appr. 1.7 VA at 220 VAC

Operating temperature: +14° to 140° F (-10° to +60°C)

Environmental Protection: IP51 (front side in built-in state)

Count range: 99999.99 hours; 9999999 counts

Display: Dual 7 digit display with characters magnified to 0.157" (4mm) high.

Color of Figures:

White on black for hours, red on white for decimal hours
White on black for totalizing counter.

Color of Housing: Black

Weight: 2.3 Oz. (65g)

Approvals: CE Approved

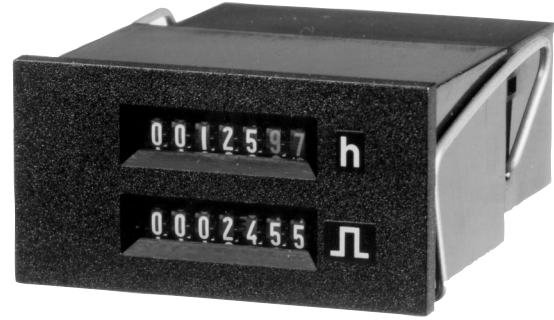

Dimensions:

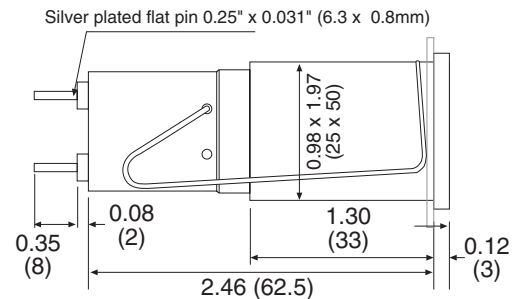
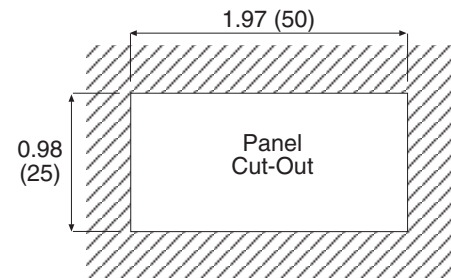
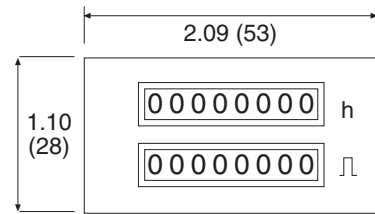

How To Order:

EXAMPLE: HC67 110VAC 60Hz

Series _____

HC67

Voltages _____

110V (AC Voltages ±10%)

220V (AC Voltages ±10%)

Frequency _____

50 or 60Hz (Specify)

M Series

Multi-Resolution Elapsed Timers

Features

- All Standard Voltages
- Electric, Manual, or Non-Reset Available
- Varied Resolutions Available
- Varied Mounting Styles
- Many Options Available



Description:

The M Series hours, minutes and seconds timer offers more voltages, reset options and more resolutions than any other electromechanical timer made today. Driven by a solid state circuit, with control line input that insures .05% accuracy, these timers provide instrument level performance.

Specifications:

- Display:** 5 or 6 digit with reset 5 or 8 digit without reset
- Digit:** .160" high (each time designation has color-coded wheels for easy display)
- Operating Voltage:** 6, 12, 24, 48, 110VDC; 12, 24, 110, 220VAC
- Accuracy:** AC-based on line frequency, DC-crystal oscillator rated at .05% accuracy
- Power Consumption:** 2.5 W typ., 9 W required for reset
- Supply Voltage:** ±10% of rated voltage
- Supply Ripple:** 10% maximum (DC units only)
- Temperature:** +32° F to +112° F (0° C to +45°C) operating

Mounting:

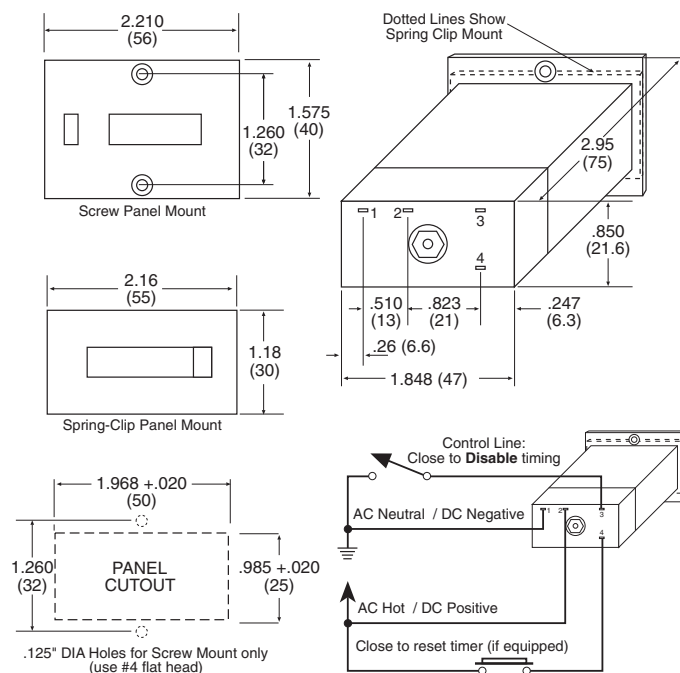

How To Order

EXAMPLE: MTH 16. 1 1 12VDC V

Series

AC with Reset:

- MTH16. (Hours 1/100)
- MTM15. (Minutes 1/10)
- MTS16. (Seconds only)
- MTHMS16. (Hrs, Min, Sec)
- MTHM15. (Hrs, Min 1/10)

AC without Reset:

- MTH18. (Hours 1/100)
- MTM17. (Minutes 1/10)
- MTS18. (Seconds only)
- MTHMS16. (Hrs, Min, Sec)
- MTHM15. (Hrs, Min 1/10)

DC with Reset:

- MLTH15. (Hours 1/100)
- MLTM15. (Minutes 1/10)
- MLTS16. (Seconds only)
- MLTHMS16. (Hrs, Min, Sec)
- MLTHM15. (Hrs, Min 1/10)

DC without Reset:

- MLTH17. (Hours 1/100)
- MLTM17. (Minutes 1/10)
- MLTS18. (Seconds only)
- MLTHMS16. (Hrs, Min, Sec)
- MLTHM15. (Hrs, Min 1/10)

Mounting:

- 1 = Screw panel
- 2 = Spring clip
- 0 = Rear Mount (for F1K1 Option Only)

Reset:

- 0 = Non-reset
- 1 = Manual
- 2 = Electric
- 3 = Manual and electric

Voltage (specify)

- DC - 6, 12, 24, 48, 100
- AC - 12, 24, 110, 220

Available Options:

- TB - terminal block
- V - manual reset guard
- US - spade key reset
- ML - magnifying lens
- HT - extended temperature (+32°F to +140°F)
- F1 - screw panel mount frame w/ socket box (cutout W2.15" x H1.20")

Enclosures:

- F1DK - transparent polycarbonate cover, keylock, tamper-proof.
- F1DV - transparent polycarbonate cover, knob closure
- F1K1 - silicone cover, 0 mount style

Enclosures:

- N7 - explosion proof
- N4 - weatherproof
- N12 - dust and oil tight

HB26 Series

Hour Run Meter with Reset

Features

- REPLACES HB16 SERIES
- Operation Indicator: Fast Rotating Gear Wheel
- Driven By A Synchronous Motor
- Wide Variety Of Operating Voltages
- Small Size
- Long Life
- Low Cost

Applications:

Engine Hour Meters
Rental Equipment
Maintenance Timer

Description:

This 6 digit hour meter is the perfect timer when low cost, small size and high quality are important. It is available in AC or DC voltages with manual reset. Highly visible white on black hour digits including red on black decimal digits. Unit is also pluggable into socket box 945.2.

Specifications:

Color of Housing: Black

Digits: 6, .177" (4.5mm) high

Display: 9999.99h for AC models, 99999.9h for DC models

Hours: white figures on black

Decimal digits: red figures on black

Reset: Manual reset

Operating Voltages: 24, 115, 230 VAC, +/- 10% 50/60 Hz
12-24, 36-80, 115 VDC +/-15%

Termination: Wire leads .078" x .019² (2mm x .5mm²)
NYFAZ 19.685" long (.5m)

Temperature: 14°F to 122°F (-10°C to 50°C)

Power Consumption: Appr. 2 VA at 230 VAC, Appr. 80mW at 12 VDC, Appr. 270mW at 24 VDC

Weight: 2.116 ounces (60 grams)

Protection: IP 42 front side, sealing cover K1: IP 54 front side, Transparent cover Dv and Dvs: IP 55 front side

Approvals: CE Approved

Options:

Spade Key Reset (US, Secret Reset (SR)

Flexible sealing cover: K1

Flat pins .031" x .110" (.8mm x 2.8mm)

with push-on connectors

Flat pins .031" x .248" (.8mm x 6.3mm)

with-out push-on connectors

Accessories:

Socket box: 945.2

Flexible sealing cover: K1 black

Front bezels: F1 black

Dummy housing .984 x 1.968 (25 x 50mm) grey, black



How To Order:

EXAMPLE: HB26 1 1 110VAC 60HZ

Series _____	_____	_____	_____	_____
6 digit hour meter				
Mounting _____	_____	_____	_____	_____
0 = Non flange				
1 = Screw panel mount				
2 = Spring clip				
3 = Large screw panel				
Reset _____	_____	_____	_____	_____
0 = none				
1 = panel reset				
Voltage _____	_____	_____	_____	_____
24, 115, 230 VAC (±15%)				
12-24, 36-80, 115 VDC (±15%)				
Frequency (AC only) _____	_____	_____	_____	_____
50 or 60 Hz				

Available Options (add to end of part number)

K1 - Silicone cover #3 mount style

F1 - Frame - with socket box 945.2

0 Mount only

945.2 - Socket box

F1DVS - Frame with locking cover & 945.2 socket box

F1DK - Frame with knob closure cover & 945.2 socket box

FL - 6" (253mm) Wire Leads

US - Spade Key Reset

TB - Terminal Block

SR - Secret Reset

NOTE: The HB26 replaces the HB16

TIMERS

Mounting:

0 Mount Style

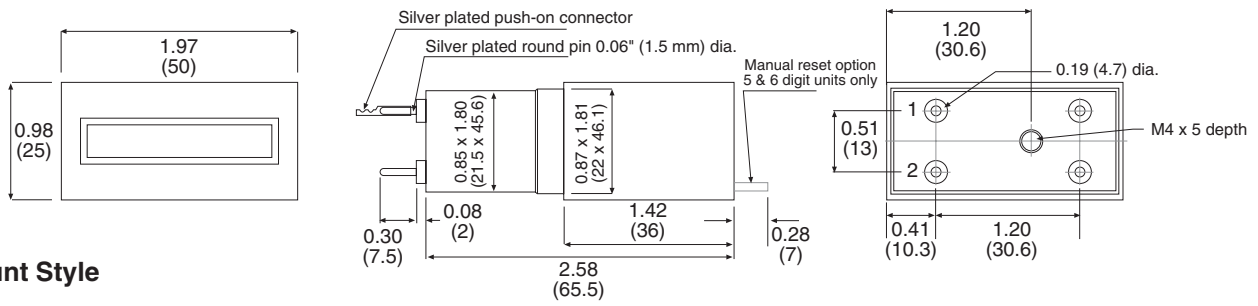

1 Mount Style

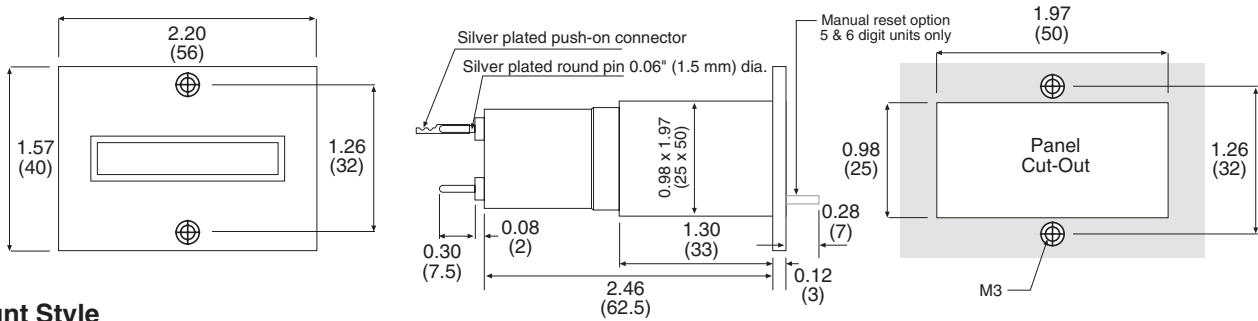

2 Mount Style

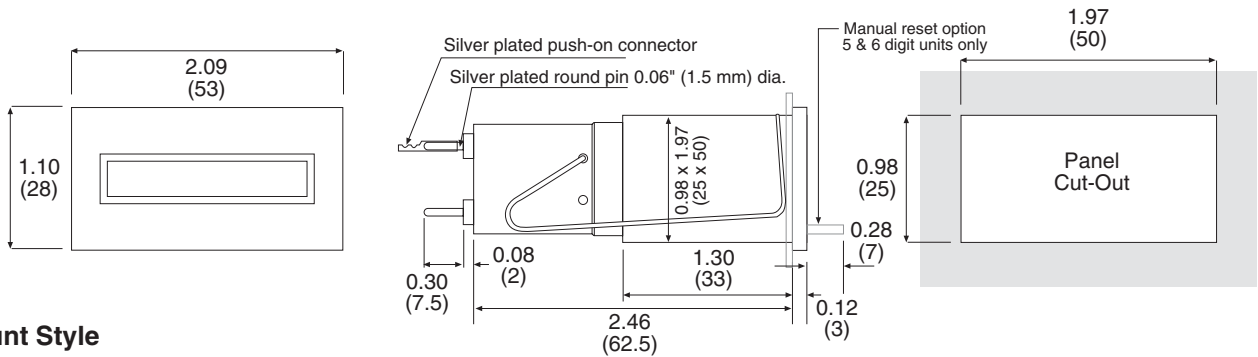

3 Mount Style

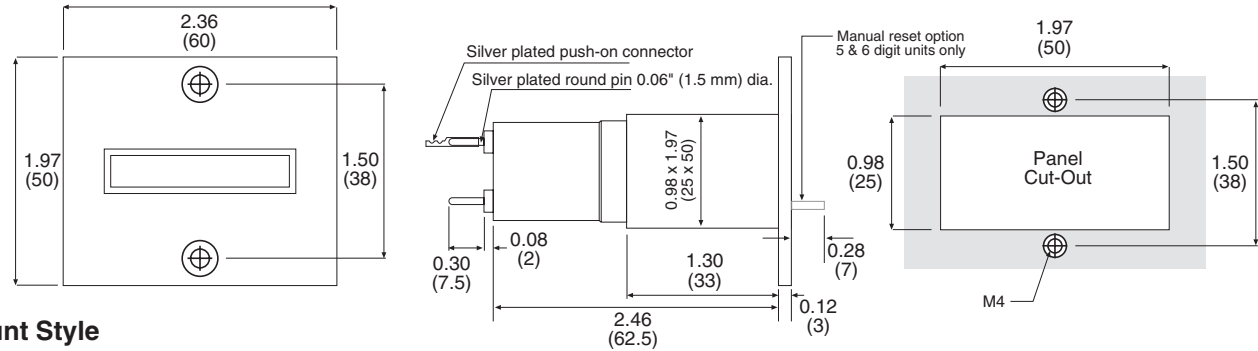

F1 Mount Style

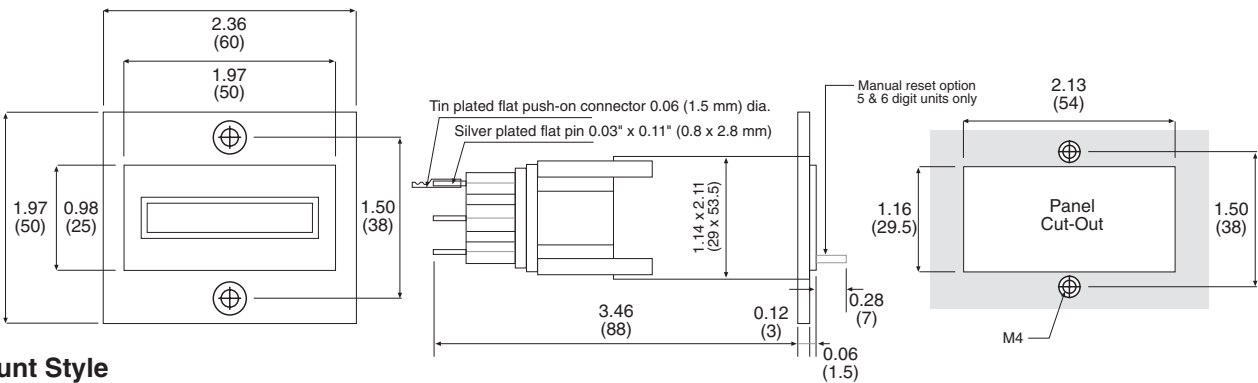

H37 Series

Hour Run Meter

Features

- Operation Indicator: Fast Rotating Gear Wheel
- Driven By A Synchronous Motor
- Wide Variety Of Operating Voltages
- Less Than 2" Deep

Description:

This hour meter is the perfect timer when low cost, small size and high quality are important. It is available in 7 digits without reset. Engine hour meters, rental equipment, maintenance timer and telephone usage are a few of the applications using this timer.

Specifications:

Color of Housing: Black

Digits: .160" high

Display: 99999.99 (7 digits) AC Units
999999.99 (8 digits) DC Units

Decimal digits: red figures on black

Hours: white figures on black

Drive: synchronous motor for AC units
stepping motor for DC units

Resolution: Hours & 1/100ths.

Reset: non-reset

Operating Voltages:

DC: 12-24, 36-80, 110 ± 15%

AC: 24, 110, 220 ± 15%

Accuracy: .05%

Termination: Flat tabs .031 x .250" with screw terminal

Temperature: + 5° F (-15° C) to + 122° F (50° C)

Power Consumption:

on 24 and 110 VAC approx. 1.5 VA

on 220 VAC approx. 2 VA.

on 12 VDC approx. 85 mW.

on 24 VDC approx. 170 mW.

Approvals: CE Approved



Dimensions:

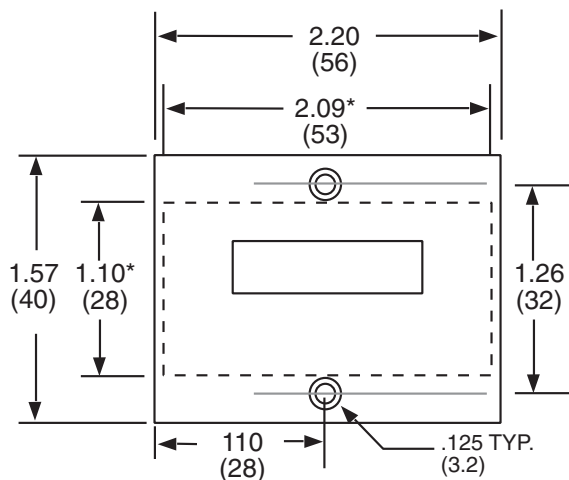

* 2.09 x 1.10 Dimensions Are For Spring Clip Mount; 2.20 x 1.57 Are For Panel Mount.

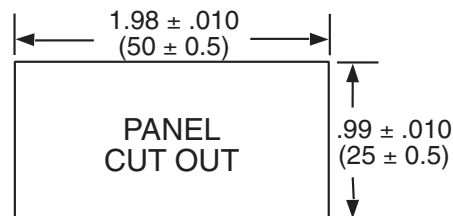
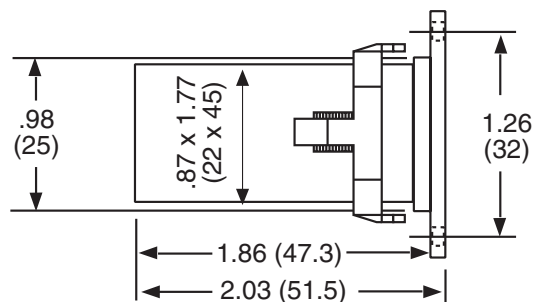

How To Order

EXAMPLE: H37 2 0 110VAC 60HZ

Series _____

7 digit hour meter

Mounting _____

1 = panel mount

2 = spring clip

Reset _____

0 = none

Voltage _____

12-24, 36-80, 110 VDC (±15%)

24, 110, 220 VAC (±15%)

Frequency (AC only) _____

50 or 60 Hz

NOTE: The H37 replaces the HB17

KAL-DIN TIME

Battery Powered Time Indicator

Features

- Multi-Resolution Time Ranges:
Sec., Min. & Sec, Hrs & Min. or Hrs & 1/100ths
- Battery Powered
- 8 Digit LCD Display
- Remote & Front Panel Reset
- NEMA 4X / IP65 Front Panel

Applications:

For timing industrial processes, machine down time / on time indicator, event timing, monitor testing time.

Description:

The KAL-DTIME1 and KAL-DTIME2 are 8 year, lithium battery powered, elapsed timers with the following resolutions: minutes and seconds (KAL-DTIME1) or, hours and minutes, or hours and 1/100ths (KAL-DTIME2). The front panel meets NEMA 4X/IP65 standards. The display has 8 large digits each 0.276" high.

Specifications:

Power: Internal Lithium Battery (life 8 years calculated).

Display: 8 digit, LCD, 0.276" high.

Accuracy: $\pm 0.003\%$ @ 25°C

Temperature Drift: .035 PPM/°C²

Aging: 3 PPM/Year max.

Temperature Range: 14 to 140°F (-10 to 60°C)

Signal Inputs:

Pin 4 — Contact Closure Time; Negative level active

Low: <0.7 VDC, High: open or 3 to 18 VDC

Pin 3 — Reset-Contact closure to common resets, level triggered, min. pulse width 12mS.

Pin 2 — Reset Enable; link to common (Pin 1) to enable front reset.

Pin 5 — Timing Mode Select;
KAL-DTIME1 - Min. & Sec.
KAL-DTIME2 - Hours & 100ths

LEFT OPEN

KAL-DTIME1 - Seconds

KAL-DTIME2 - Hours & Minutes

Approvals: UL File: E135458, CSA File: LR96702,
CE Approved

Material: ABS Plastic

Weight: 1.7 oz.

Battery Life: 8 years (calculated)

Connection: 5 pin, plug in connector with 9" leads supplied with timer.

Sealing: Front Panel sealed to NEMA 4X/IP65

Mounting: Spring clip mount provided. Optional two screw mounting and/or competitor retro-fit available.

Note- A 5-240 VAC or DC pulsing module is available as "KAL-DTIME AC/DC."



Hookup:

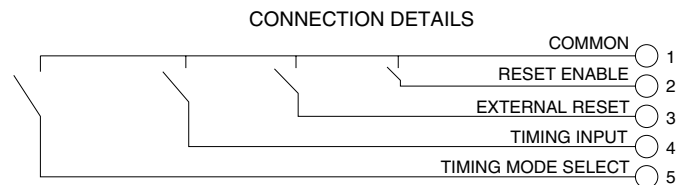

Mounting:

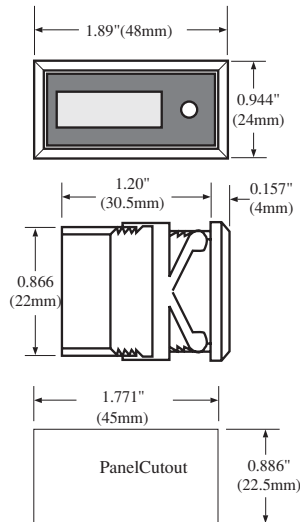

Adaptors (included) KAL-DP1X2

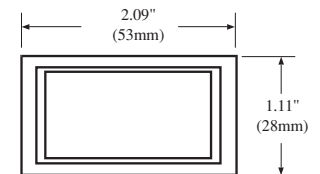

KAL-DP1

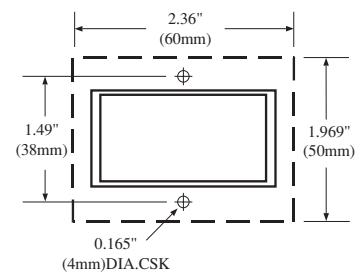

NOTE: KAL-DP1x2 and KAL-DP1 panels are included

TERMINAL BLOCK MODULE

Description -- KAL-D TB

(For screw terminal connection with standard pulse characteristics)

Pin numbers shown on terminal block correspond to wire lead numbers.

Two Pins #1 are internally connected.

DO NOT CONNECT KAL-D TB TO AC VOLTAGE

5-240 VOLT INPUT MODULES

Description -- KAL-D AC/DC (Counter) KAL-DTIME AC/DC (Timer)

The KALD AC/DC Module enables the KALD to accept 5-240 VAC/DC input signals. (The KAL-DTime AC/DC is used for the KAL-DTIME series). The module snaps into the back of the counter. The circuitry allows various voltage pulses to be used for counting and provides opto-isolation of 2500V.

KAL-D AC/DC (Counter) SPECIFICATIONS:

Signal Inputs:

18 Hz max. (15 msec. pulse width min.)

5 to 48 VAC/DC

Low: < 1.5 VAC/DC or open

High: 5 to 55 VAC/DC

48 to 240 VAC/DC

Low: <15 VAC/DC or open

High: 48 to 264 VAC/DC

Input Impedance:

5 to 48 VAC/DC - 10K ohms

48 to 240 VAC/DC - 58.5K ohms

Reset:

Dry contact closure only.

15msec. min. pulse.

Temperature Range:

Same as KAL-D series

Terminal Block (TB) Adaptor Connections

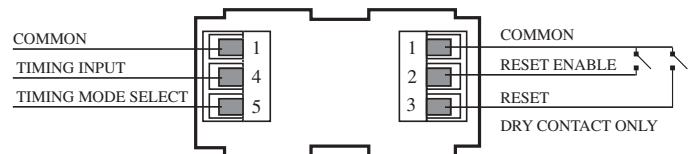

Dimensions for AC/DC Adaptor and Terminal Block

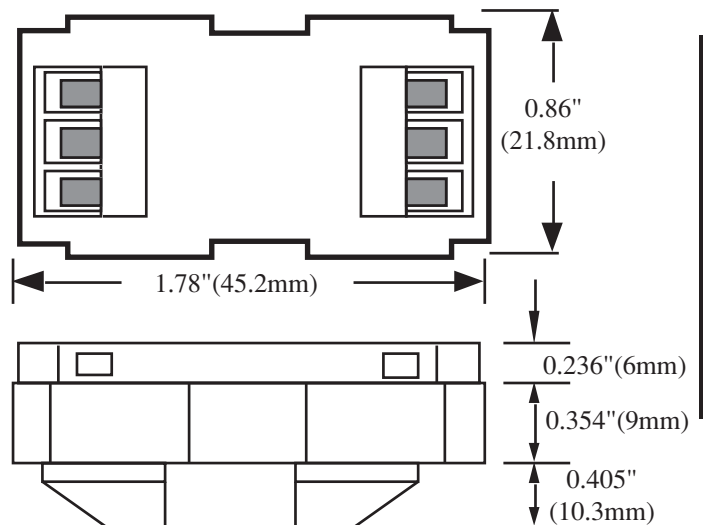

TIMERS

AC/DC Adaptor Connections

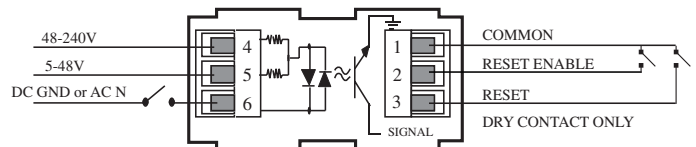

NOTE: Jumper terminal 5 to terminal 6 to raise the low threshold to 25V for triac inputs or when low voltage does not reach 0V. Connect input to terminals 4 & 6.

It may be necessary to place a 10 kΩ 7W resistor across terminals 4 & 6 to bring voltage below 25V.

How To Order:

Part Number	Description
KAL-DTIME1	Sec., or Min. & Sec. Timer
KAL-DTIME2	Hours & 100ths or Hrs. & Min. Timer
KAL-DTIMEAC/DC	5-240V AC/DC input module
KAL-DTB	Terminal block adaptor

Accessories

N7 - Explosion proof housing (see accessories section)

E200 - Outdoor Enclosure (see accessories section)

134K-135K

Battery Powered Hour Meters with LCD Display

Features

- Low price and high efficiency
- Large (8 mm) 8-digit LCD display,
- Optional backlighting
- Different time ranges from 0.1 second to 100,000 hours
- 0.1 second synchronization makes it suitable for very short activation times
- High voltage input for 10 to 260 V AC/DC voltage pulses
- Very high accuracy: 100 ppm
- NEMA4/IP65 Front Panel
- Screw terminals, RM 5 mm



- Lifetime of the battery approximately 8 years
- Locking of the reset key
- Operating temperature -10 to $+60$ °C

Technical data

Power supply: non-replaceable lithium battery (lifetime approximately 8 years at 20°C)

Backlighting: external electrical source 24 V DC $\pm 20\%$, 50 mA

Display: LCD, 8 decades, 8 mm high characters

Display range: -9999999 to 99999999 , with overflow display

Reset: manual and electrical

Timing inputs:

A. Standard DC Input (max. 30 V DC)

NPN or PNP

Switching level:

NPN: Low: 0 to 0.7 V, High: 3 to 30 V DC

PNP: Low: 0 to 0.7 V, High: 4 to 30 V DC

B. High Voltage Input (10 to 260 V DC/AC)

Timing input: Optocoupler input, max. 30 Hz

Min. pulse time: 16 ms

Switching level: Low: 0 to 2 V DC/AC, High: 10 to 260 V DC/AC

C. Timing range switching (Mode)

Time Range: see order table

Contact input:

Open Collector NPN (switching at 0 V DC)

Switching level:

NPN: Low: 0 to 0.7 V, High: 3 to 5 V DC

D. Reset Input (only DC and high voltage)

Minimum pulse time:

DC: 50 ms, high voltage: 16 ms

Contact input DC*:

NPN: Low: 0 to 0.7 V, High: 3 to 30 V DC

High voltage input: 10 to 260 V DC/AC

E. Electrical reset key locking (for DC and AC)

Input not active: Reset key locked

Contact input:

Open Collector NPN (switching at 0 V)

Switching level:

NPN: Low: 0 to 0.7 V, High: 3 to 5 V DC

Interference emissions:

EN 55011 Class B, EN 61000-6-2 EN

61010 Section 1 (only AC versions)

Housing: dark grey RAL 7021

Operating temperature:

-10 to $+55$ °C

Ambient temperature:

-10 to $+60$ °C

Storage temperature:

-20 to $+70$ °C

Protection: NEMA4/IP65 front

Weight: approximately 50 g

Dimensions:

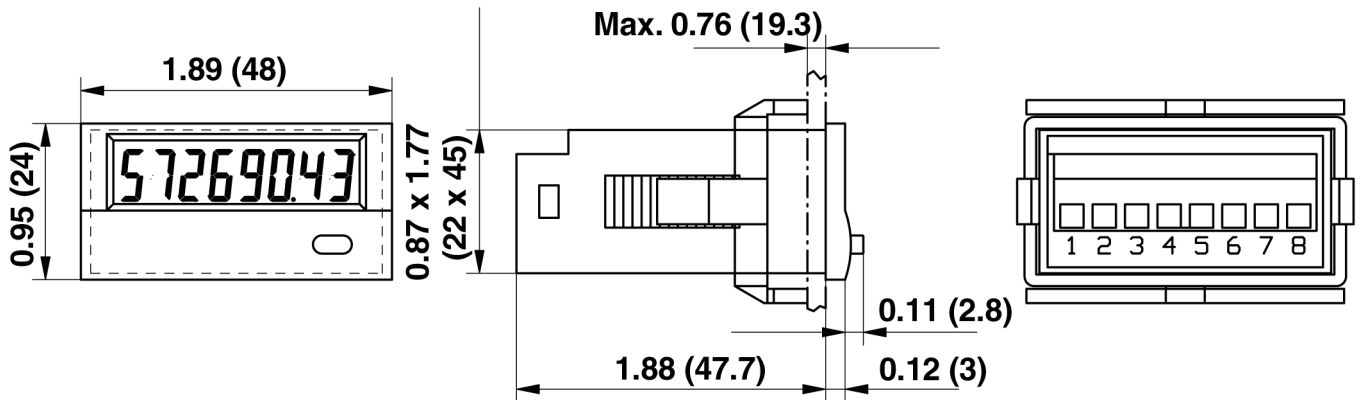

Order Table

Type	Mode	Time range	Inputs			
			INP A		INP B	
134K.012.8x0	Timer	99999h 59 m/ 99999.99 h	—		0 ... 0,7 V DC	NPN
134K.012.8x1			—		4 ... 30 V DC	PNP
134K.012.8x3			10 ... 260 V AC/DC	AC/DC	10 ... 260 V AC/DC	AC/DC
135K.012.8x0	Timer	9999 h 59 m 59 s/ 9999999.9 s	—		0 ... 0,7 V DC	NPN
135K.012.8x1			—		4 ... 30 V DC	PNP
135K.012.8x3			10 ... 260 V AC/DC	AC/DC	10 ... 260 V AC/DC	AC/DC

X: 5 = no backlight

X: 6 = with backlight

Accessories

N7 - Explosion proof housing (see accessories section)

E200 - Outdoor Enclosure (see accessories section)

XL-10

Battery Powered Elapsed Time Indicator

Features

- 6 Digit Display
- 5-260 VDC or VAC Count Inputs
- Switch Closure Inputs
- Programmable Resolution
- 10 Year Battery Operation
- 2-Wire Hook-Up
- Backlit Display (optional)
- Heated (optional)

TIMERS



Description:

The XL-10 timer series offers a wide variety of time bases, crisp, sharp liquid crystal display digits and a built-in power source designed to last 10 years. Digits .5" high readout in hours, minutes or seconds and tenths or hundredths of any basic time resolution. An extruded aluminum housing provides good looks and a rugged frame perfect for most industrial applications. Best of all, simple 2 wire installation makes replacing older electro-mechanical timers a snap. In short, the XL-10 timer brings state of the art technology to electromechanical applications at a price that is designed to fit your budget.

Switch Settings

1	2	3	4	5	6	7	8	
X								Sec. 1/10
	X							Sec.
		X				X		Min. 1/100
			X			X		Min 1/10
				X		X		Hrs. 1/100
					X	X		Hrs. 1/10
		X						Min.
					X			Hrs.
							X	Level Activation (switch closure)
								JK Activation (pulse to start, pulse to stop)

X = Switch On

Specifications:

Timing Range:

Hours, hours and 1/10ths, 1/100ths. Minutes, minutes and 1/10ths, 1/100ths. Seconds, seconds and 1/10ths.

Power Supply:

Built-in lithium battery designed for 10 years life. No external power source required.

Mounting:

Wall or Panel Reset: Key operated or push-button.

No. of Digits:

6 liquid crystal display.

Temperature:

No external power source needed for use in applications to -20°C. Optional heater operates from an external 12 to 28 Volt source, permitting operation to -40°C.

Backlighting:

For use where ambient light is insufficient or night viewing is required. This optional feature is powered by a separate 110 VAC and use of this feature in no way affects the lithium battery which powers the timer itself.

Termination:

10" long color coded wire leads.

Initiation:

Pulse, momentary, switch closure, voltage level or single dry switch. Pulse activation requires 10 m/s min. pulse width. 5-11 volts AC/ DC or 12-260 volts AC/DC may be used for pulse activation.

Accuracy:

0.1% based on an internal 60Hz time base.

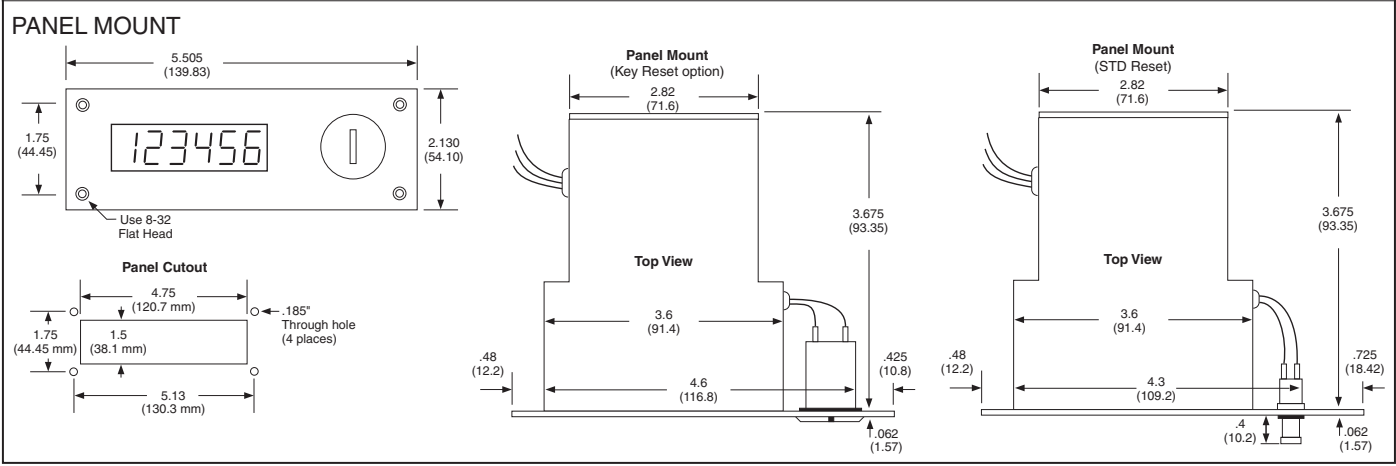
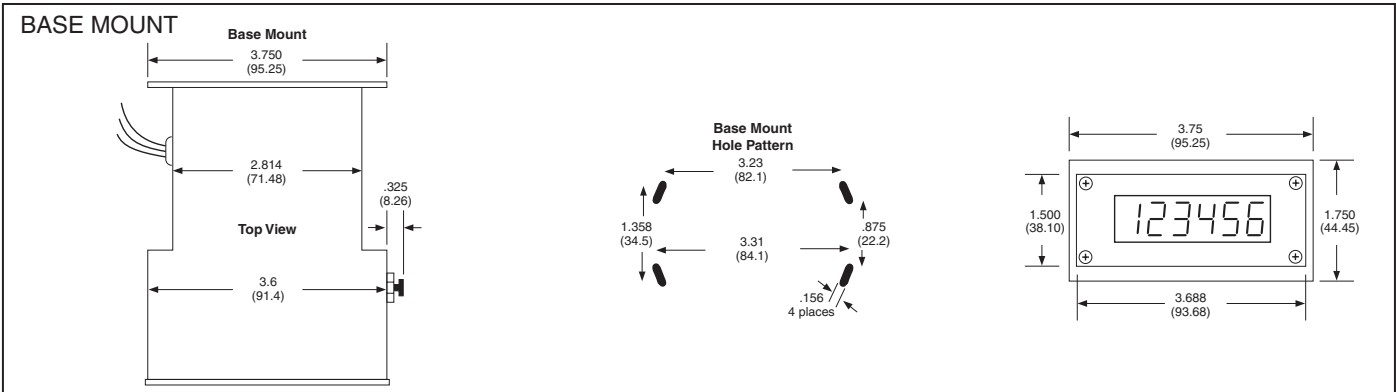

Wiring:

Timer Inputs VL & JKV (12 to 260 V)

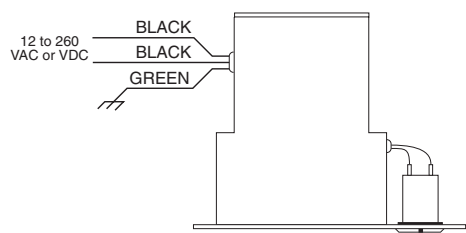

Timer Inputs VL & JKV (5 to 11V)

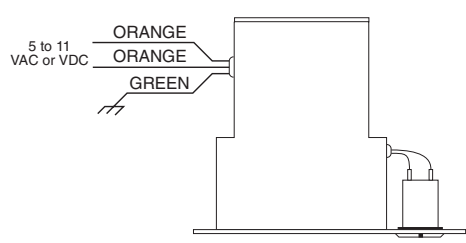

Timer Inputs C & JKC (Contact closures)

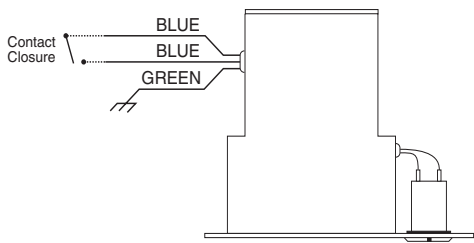

How To Order:

EXAMPLE: XL-10 P 1 JKV(5) 2 LT

Series	Mounting	Reset	Input to Time	Timing Resolutions	Options
XL-10	P	1	JKV(5)	2	LT
<p>P = Panel (front reset) B = Base (side reset)</p> <p>1 = Standard reset 2 = Key switch (Panel mount only)</p> <p>C = Dry switch closure VL = Voltage level (specify voltage) JKC = Momentary switch closure (on/pulse off/pulse) JKV = Voltage pulse (on/pulse off/pulse; specify voltage)</p> <p>1 = Hours 2 = Hours & 1/10ths 3 = Hours & 1/100ths 4 = Min. & 1/10ths 5 = Min. & 1/100ths 6 = Seconds 7 = Seconds & 1/10ths 8 = Minutes</p> <p>BL = Back lighting RR = Remote Reset LT = Heated—Add LT for -20°C to -40°C (requires external 12 to 28 VAC or DC power supply)</p>					

HVA

Preset Hour Meter

Features

- Rugged Case
- Varied Mounting Styles
- Manual Reset
- 5 Amp Switch
- Times Up to Preset
- Preset Displayed Permanently

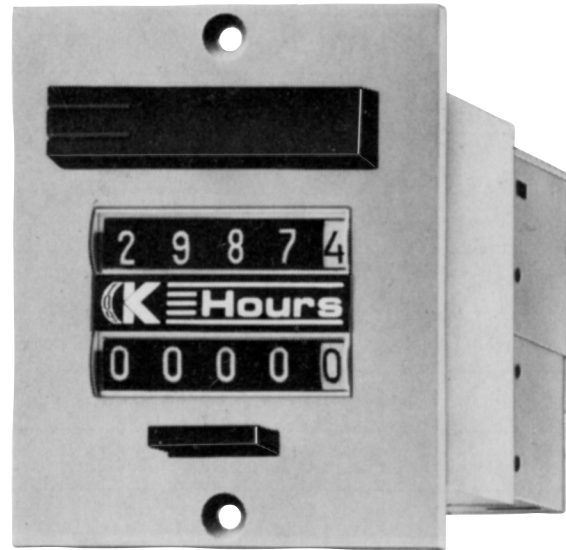

Application:

Perfect adding preset timer for chemical processes, electroplating baths, controlling periods of time, and endurance tests.

Description:

Dual display 5 digit, preset. These units feature two registers, one for the set point, one for the actual time. Change setpoint during a run with front panel buttons. Manual reset on front panel. Upon reaching preset, a 5 amp Form C switch trips. The timer continues timing to register actual time elapsed. Panel or spring clip mount; accepts most voltages AC/DC; keylock transparent cover available.

Specifications:

Display: 4 hour digits-white on black, 1 decimal digit-red on black.

Digits: Preset (.157"), counting (.197")

Resolutions: Hours 1/10

Operating Voltages: 12, 24, 48VDC; 24, 48, 110, 220VAC.

Power Consumptions: 1.5W, DC; 2.2 VA, AC.

Switching: 5 amp Form C transfers at preset.

Switch Rating: AC load max. 250V 5A DC load max 12V 3A; 24V 2A.

Arc suppression recommended for inductive load.

Temperature: (-10°C to +50°C) +12°F to ±122°F.

Weight: 5 oz.; including frame, 7 oz.

Approvals: CE Approved

Wiring:

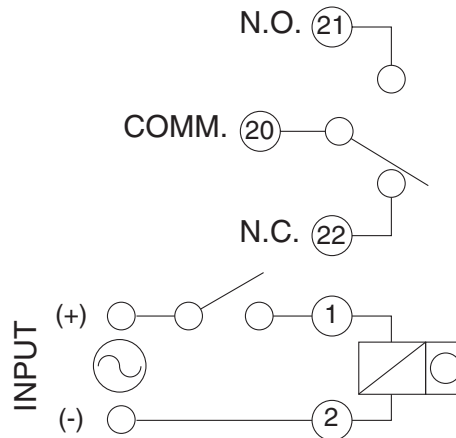

0 Mounting Style:

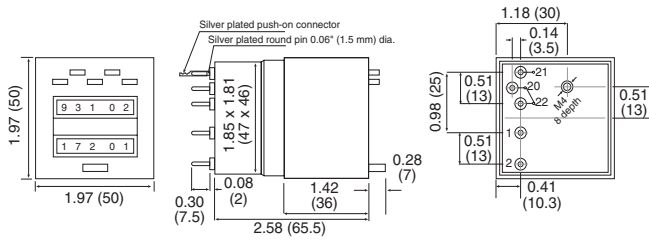

1 Mounting Style:

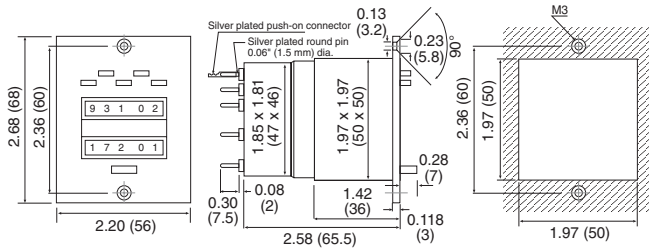

2 Mounting Style:

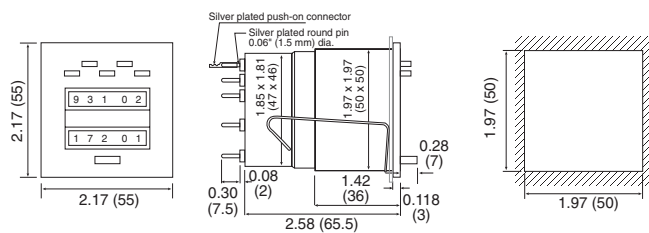

3 Mounting Style:

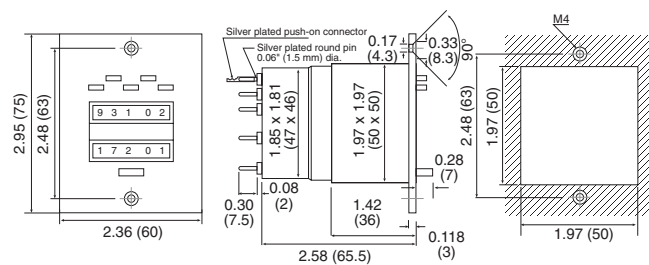

F2B Option:

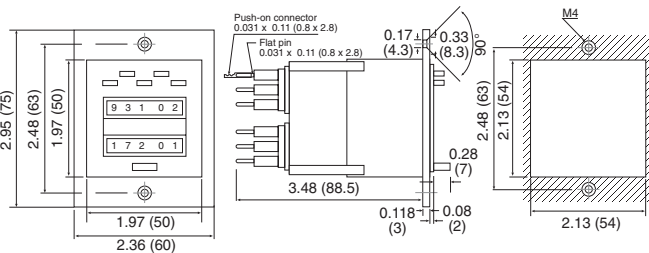

F2DV Option:

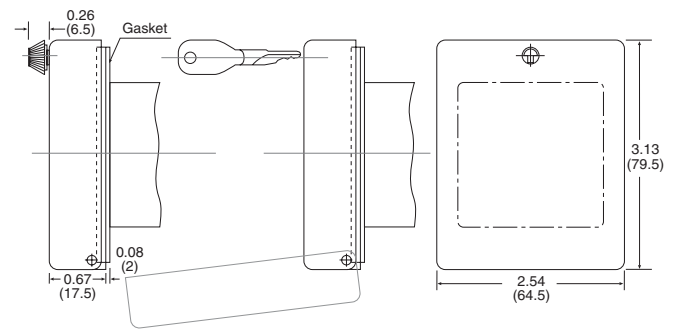

F2DVS Option:

K2 Option:

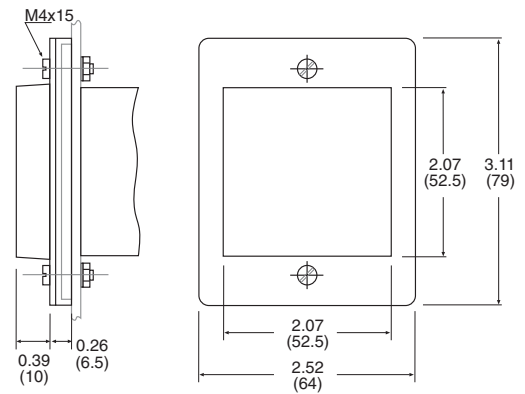

How To Order:

EXAMPLE: HVA15 1 1 110VAC 60Hz

Series _____

Mounting _____

- 0 = Rear stud mount
- 1 = Screw panel
- 2 = Spring clip
- 3 = Large screw panel

Reset _____

- 1 = Manual push button

Voltages (specify) _____

- 12, 24, 48 VDC
- 24, 48, 110 and 220 VAC

Frequency (AC only) _____

- 50 or 60 Hz

Available Options (add to end of part number)

- K2 - Silicon cover
- F2 - Frame w/ Socket Box
- F2DVS - Frame w/ locking cover & Socket Box
- F2DV- Frame w/ knob cover & Socket Box
- US - Key reset
- DVS -Locking cover without Frame
- DV - Knob cover without Frame
- N7 - Explosion proof housing (see accessories section)

DT20 Series

Day Timer with 20 Programmable Presets

Features

- 24 Hour (AM & PM), 7 Day Programming
- 20 Programs Provide Up To 10 ON & 10 OFF Events Per Day / Week
- Rechargeable Battery Backup With 100 Hour Carry-Over
- 16 Amp, SPDT Relay
- Manual Override
- Several Mounting Styles Available



PRESET TIMERS

The DT20 is a compact electronic 24 hour/7 day time switch module, with heavy duty relay contacts for switching low or line voltage loads. Applicable for time of day control of pumps, fans, heaters, HVAC control circuits, lighting, machinery and many other types of commercial, industrial, and agricultural equipment.

All models feature large keys with unique "circular programming" for easy programming, a large LCD display and battery backup.

TECHNICAL DATA:

Channels:	1
Programs:	20
Manual 3 way override:	On-Auto-Off
Shortest switching time:	1 minute
Reserve carryover:	100 Hours
Input voltage:	24VAC/DC 120VAC 208/240VAC
Switching output:	SPDT relay
Switch ratings:	16A @ 277VAC 25ma, 40VDC 1000W Tungsten @ 250VAC 500W @ 125VAC

Input draw: 4VA

Input frequency: 50 or 60Hz

Wiring connections: 1/4" quick connects

Ambient temperature: -20° F to 140° F (-28° C to 60° C)

Approvals: UL and Canadian UL recognized: File E83486

MOUNTING OPTIONS:

The standard DT20 models may be surface mounted inside a panel or flush mounted with DTA-PH Base mounting kit, available from KEP. Indoor NEMA 1 (DTA-E150), and outdoor NEMA 3R (DTA-E200) enclosures are available for stand-alone mounting.

Dimensions

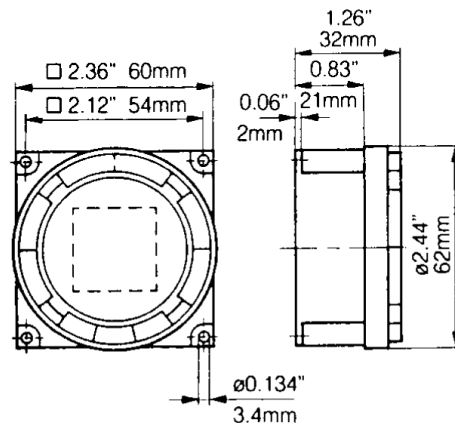

Terminal Connections

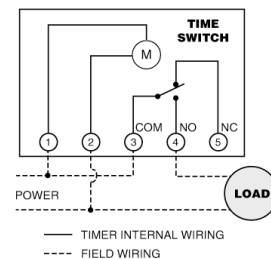

CAUTION!

RISK OF ELECTRIC SHOCK

Turn power off at main panel before servicing the DT42 or the equipment it controls.

Additional Mounting Options:

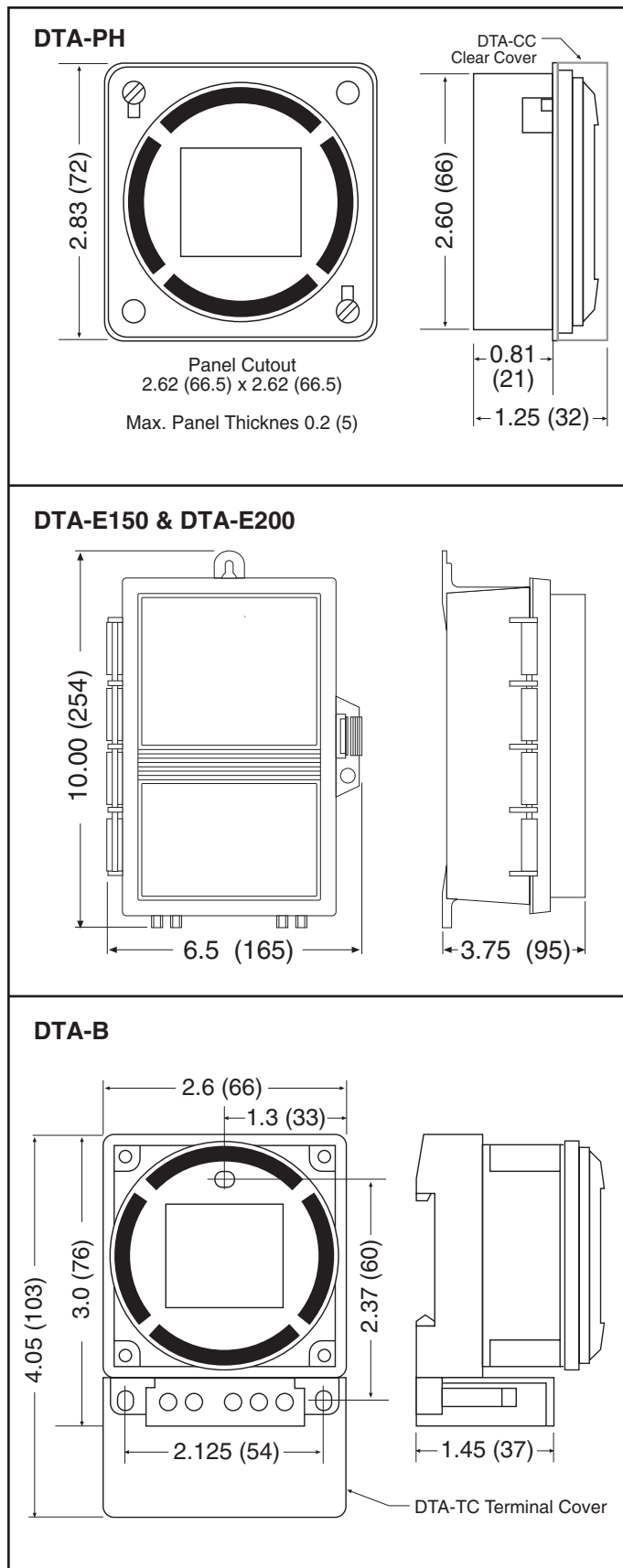

DT20 Day Timer

How To Order:

Example: DT20 A

Series: DT20 = Day Timer

Operating Voltage:

- A= 110 VAC
- B= 220 VAC
- C= 24 V AC/DC

Mounting Accessories

- DTA-PH = Panel Housing for Panel Mount
- DTA-CC= Clear Cover for Panel Housing (DTA-PH)
- DTA-B= Base with Screw Terminal
(not for panel mounting)
- DTA-TC= Terminal Cover for DTA-B
- DTA-E150= Indoor Enclosure
- DTA-E200= Outdoor Enclosure

TR-910

Programmable Time Relay with LCD Display



Features

- Easy Operating and Programming Using Front Keypad
- Self Powered with Internal Replaceable Lithium Battery
- High Contrast, 2-line, 5-digit, LCD-Display
- 9 Programmable Time Ranges from 0.20 Seconds up to 99999 Hours
- Relay Contacts Rated at 8A; Programmable to NO or NC
- Resolution up to 0.01 Seconds
- Universal Inputs for 12 - 260 V AC/DC
- 8 Timing Modes

- 3 Programmable Activation Modes
- NEMA4/IP 65 Front Panel
- Plug-in Connector

Specifications:

- Voltage supply:** Two, 3V AA replaceable lithium battery, service life > 10 years or 500,000 relay changes
- Inputs:** Timing Reset inputs: 12 to 260 V AC/DC, impedance 180 kΩ min. impulse 20 ms, (optocoupler)
- Display (time):** 5-digit LCD-Display; 6.5 mm high (set time, mode): 5-digit LCD-Display; 3.5 mm high
- Accuracy:** +50/-20 ms respectively 0.5 % of setting time (higher value counts)
- Repetition accuracy:** 0.3 % of setting time
- Operating temperature:** -10 to +60 °C
- Storage temperature:** -20 to +70 °C
- Relative humidity:** 80% max. up to 31 °C; decreasing to max. 50% at 40 °C
- Protection:** NEMA4/IP 65 with delivered seal

- Output relays:** SPTST voltage free contacts programmable as NO or NC
- Contact Rating:** 250 V AC at 8A; $\cos \varphi = 1$
250 V AC at 5A; $\cos \varphi = 0.4$
30 V DC at 8A; $\cos \varphi = 1$
- Reaction time:** < 20 ms
- Expected life:** 2 A ohm's load 1000000 switching cycles
- EMV:** CE-conforml to EC-guideline 89/36/EWG
- Electromagnetic:** EN50081-2/EN 55011 class B
Radiation: Electromagnetic immunity: EN6100-6-2
- Weight:** appr. 80 g
- Time ranges:** 1 s ... 99999 s; 0,2 s ... 9999,9 s; 0,02 ... 999,99s;
1 min ... 99999 min; 0,1 min ... 9999,9 min; 0,01 min ... 999,99 min;
1 h ... 99999 h; 0,1 h ... 9999,9 h; 0,01 h ... 999,99 h

Timing Modes

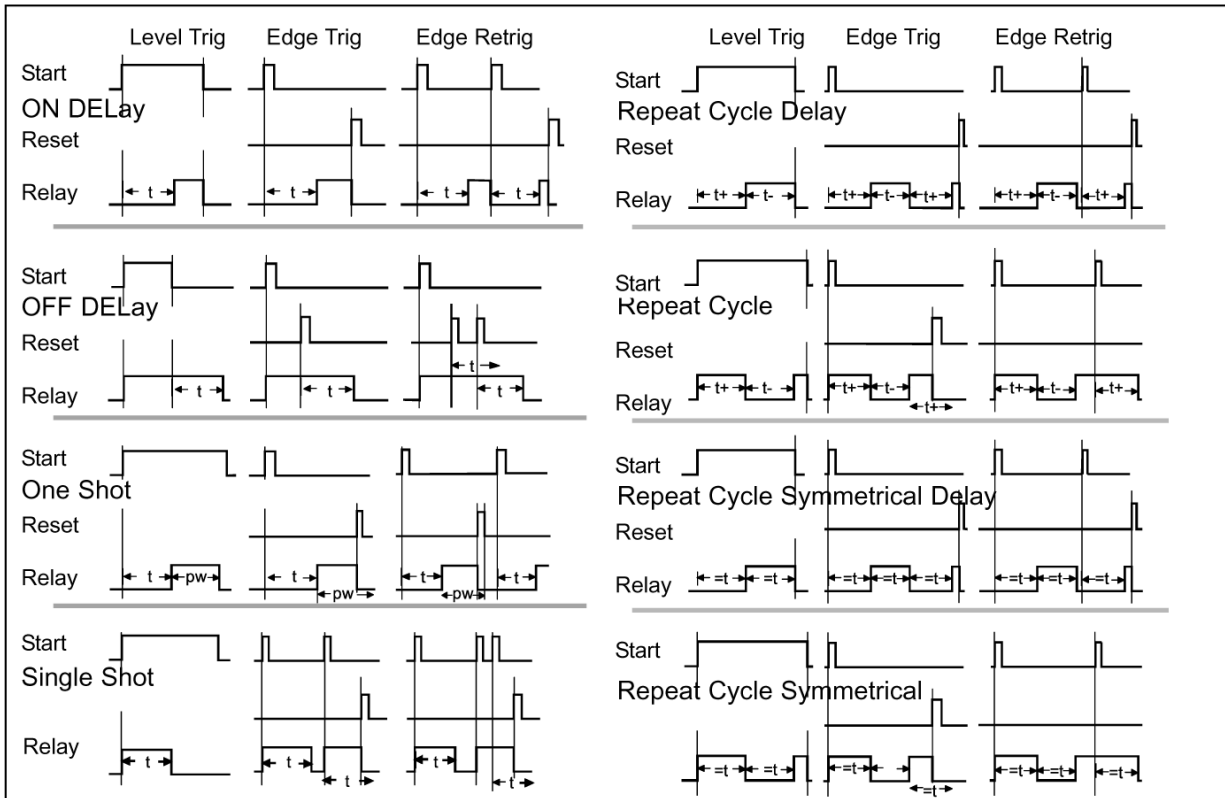

PRESET TIMERS

Dimensions

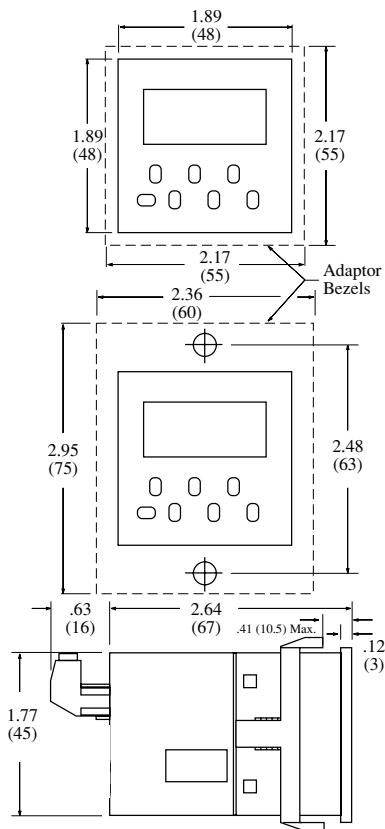

Terminal Connections

1	Common for terminals 2 + 3	
2	Timing input, programmable to level or edge triggered	These inputs can be 12 - 260 V AC/DC. For DC input the polarity is unimportant
3	Reset input	
4/5	Voltage free relay contacts, programmable to NO or NC	
6/7	Connect together to disable front panel keys	

Order Code:
Model Number: TR910.010.800

INT62A

Preset Timer with LED Display & BCD Output Option

Features

- 6 Large, LED Digits
- Contact Closure, 3 to 30 Volt DC Start/Stop Pulse
- AC or DC Power
- Remote & Front Panel Reset
- Screw Terminal Connection
- NEMA 4X / IP65 Front Panel

Applications:

Ideal for elapsed time indication applications where a large LED display is required. Equipment or machinery downtime indicator/on-time indicator.

Description:

The INT62A is a low cost, highly accurate 6 digit timer. The large, brilliant .6" red-orange LED's show the elapsed time. If there is a failure of the AC or DC power source, an internal memory system will retain all of the important information for at least ten years without any battery. The unit is housed in a NEMA 4X/IP65 front, DIN standard panel mount enclosure. See "Timer Switch Settings" section for "Time Base" ranges. The keypad is used to divide the "Time Base" from 1 to 100, change the decimal point, key-in preset times and reset the timer.

Specifications:

Mounting: Standard DIN cut-out. 3.622" (92mm) wide, 1.772" (45mm) high, 4.4" (111.8mm) max depth behind panel.

Display: 6 digit, 0.55" High LED

Power Supply: 110 VAC 50/60 Hz., 220 VAC 50/60 Hz., 12 VDC - 10% to 24 VDC + 10%.

Accuracy: Over full temperature range, an accuracy of 0.05% is obtained by the use of an internal crystal time base oscillator.

+ 5 Volt DC Output: Up to 100mA of + 5 Volt regulated power is available to supply peripheral devices.

Power Consumption: Less than 425mA required for DC operation with all options. Less than 260mA without BCD output option. AC power consumption less than 5 watts with all options.

Standby System: Internal non-volatile RAM (EEPROM) retains counts for at least ten years without power.

Housing: Standard high impact UL94V-O rated plastic case.

Temperature: Operating + 32 °F (0°C) to + 130°F (+ 54°C). Storage -40°F (-40°C) to + 200°F (+ 93°C).

Signal input: 3 to 30 Volt DC pulses of .5 ms. minimum duration.

BCD Output: Parallel TTL 5VDC compatible positive true logic four lines per digit. Six full digits of data.



TIMER SWITCH SETTINGS:

Remove front bezel revealing DIP switches (see figure below). Set the switches to the desired function according to the programming instructions following: (OFF is up, ON is down)

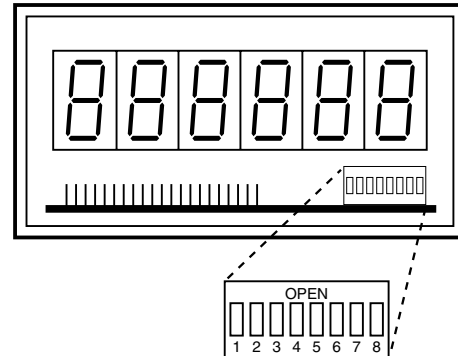

- SW 1 OFF Reset to zero
ON Reset to preset
- SW 2 OFF Level activation (continuous time)
ON Pulsed activation (start and stop on same line)
- SW 3 ON This switch must be in this position to be a timer. (if OFF it is a counter, see Preset Counter section)
- SW 4, 5 Sets time base. (see below)

SW4	SW5	TIME BASE
OFF	OFF	Seconds and 1/100
ON	OFF	Minutes and 1/100
OFF	ON	Hours and 1/100
ON	ON	Minutes and seconds

- SW 6 OFF Outputs latched until reset
ON 250 mS. output (momentary)
- SW 7 OFF Display continues to count thru preset.
ON Display recycles at preset
- SW 8 OFF Timer will not stop if reset is activated.
ON Timer stops on reset and power recovery.

Terminal Designations:

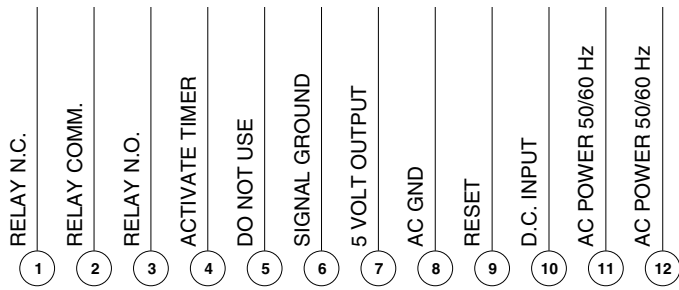

IMPORTANT:

Terminal #8 must be connected to earth ground at all times when in use. This provides a ground path for static electricity which otherwise would cause faulty operation, erroneous data or circuit damage.

BCD Option Terminal Designations:

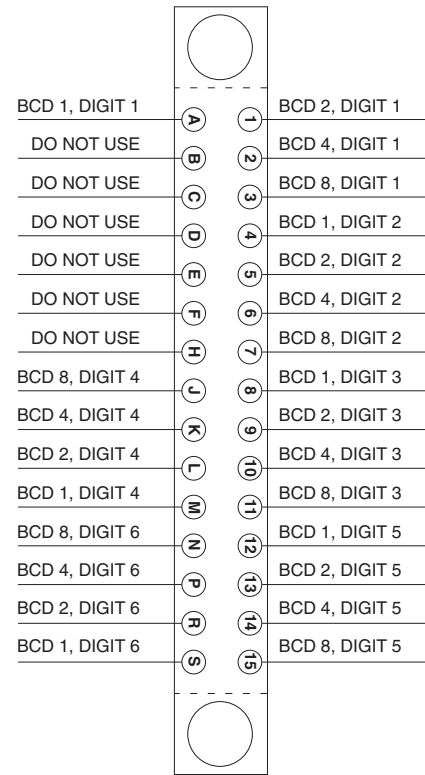

Mounting:

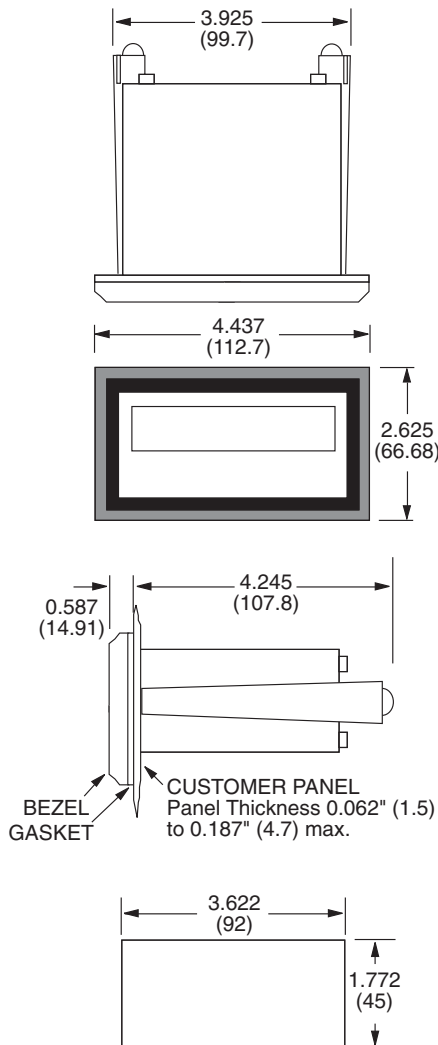

NOTE:

The BCD PCB edge connector consists of 30 gold plated and bifurcated solder connections. It is configured with two rows of 15 solder points labeled 1 to 15 and A to S. Each solder terminal will accept up to three soldered wires of #22 AWG.

How To Order:

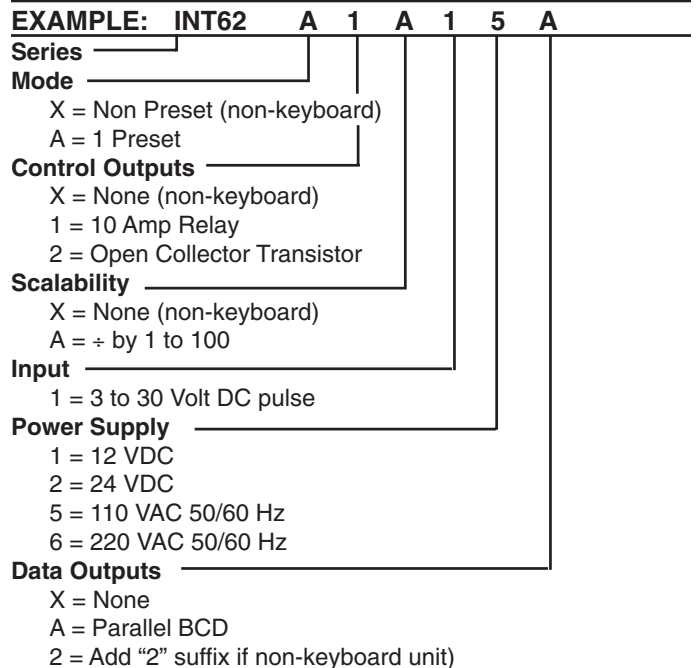

Accessories

Non keyboard panel separate: Model 34235
 Keyboard panel Model 34236

531 Series

Temperature Display for Pt100 and Ni100 RTD's

Features

- Compact and Low-Cost Temperature Display
- Temperature Display in °C or °F
- MIN/MAX Value Retention
- EEPROM Data Backup on Power Failure
- Galvanic Isolation with Reverse Polarity Protection
- Screw Terminal Connectors: pitch 5 mm
- Display Hold Input



- Easy Programming and Operation
- 5 Measurements/second

Specifications:

Supply voltage: 10-30 V DC, galvanically isolated with reverse polarity protection
 Current draw: max. 40 mA
 Display: 5-digit display, red LED's; height 8 mm
 Measuring rate: 5 measurements/second
 Display refresh: 1-2 times per second
 Data backup: EEPROM
 Housing: housing for control panel 48 x 24 mm acc. to DIN 43 700; RAL 7021, dark grey
 Ambient temp.: -20 to +65 °C
 EMC: according to EC EMC directive 89/36/EEC
 Interference emissions: EN 50081-2/EN 55 011 Class B
 Interference resistance: EN 6100-6-2
 Protection: NEMA4 / IP65 (front)
 Weight: app. 50 g
 Circuit type: 2-wire, 3-wire and 4-wire connection technique, programmable
 Input: Pt100 or Ni100 RTD with sensor breakage monitoring

Control inputs: High: 4-30 V DC, Low: 0-2 V DC
 Supply current: 1 mA
 Supply line: 2-wire: max 20 Ω, programmable 3-wire, 4-wire: max 20 Ω, no balancing required
 Temp. ranges: Pt100 acc. to DIN IEC 751:
 -199.9 °C to +850.0 °C
 -327.8 °F to +1562.0 °F
 Ni100 acc. to DIN 43760:
 -60.0 °C to +250.0 °C
 -76.0 °F ... +482.0 °F
 Resolution: 0.1°C (0.1°F) or 1°C (1°F)
 Linearity error: Pt100 < 0.1 % for entire measuring range at an ambient temperature of 20 °C
 Ni100 < 0.2 % for entire measuring range at an ambient temperature of 20 °C
 Temp. drift: 0.1 K/Kambient

Order #:

531 = Temperature Display with RTD Input

Accessories

N7 - Explosion proof housing (see accessories section)
 E200 - Outdoor Enclosure (see accessories section)

DIGITAL PANEL METERS

Wiring:

Power Supply

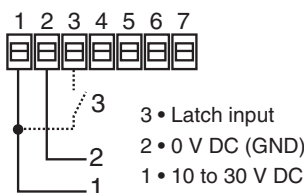

2-Wire RTD

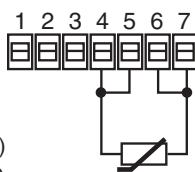

3-Wire RTD

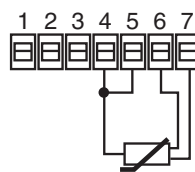

4-Wire RTD

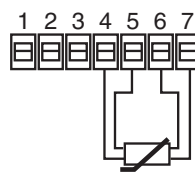

Panel Cutout: 0.876" x 1.78" (22.3 x 45.2mm)
 or 0.99" x 1.97" (25 x 50mm) with adaptor provided

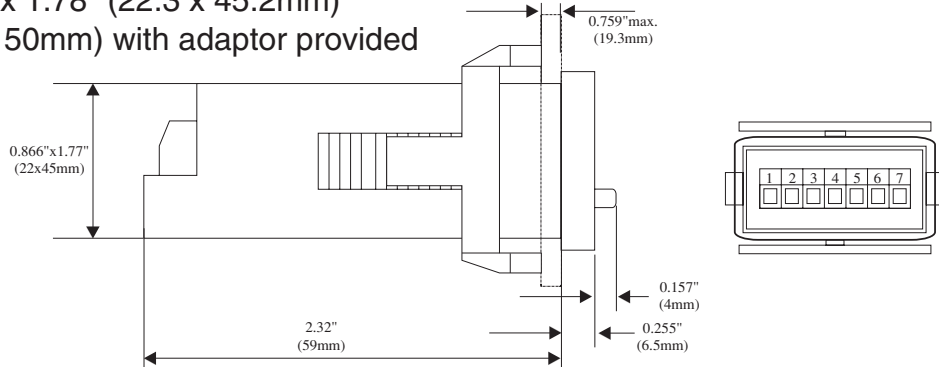
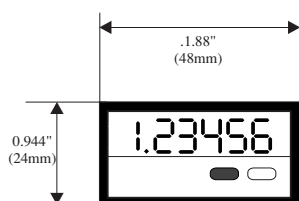

532 Series

Temperature Display for J, K and N Thermocouples

Features

- Compact and Low-Cost Temperature Display
- Temperature Display in °C or °F
- MIN/MAX Value Retention
- EEPROM Data Backup on Power Failure
- Galvanic Isolation with Reverse Polarity Protection
- Screw Terminal Connectors: pitch 5 mm
- Display Hold Input
- 5 Measurements/second



- J, K, N Thermocouples with External or Internal Cold Junction Compensation
- Easy Programming and Operation

Specifications:

Supply voltage: 10-30 V DC, galvanically isolated with reverse polarity protection

Current draw: max. 40 mA

Display: 5-digit display, red 7-segment LED's; height 8 mm

Measuring rate: 5 measurements/second

Display refresh: 1-2 times per second

Data backup: EEPROM

Housing: housing for control panel 48 x 24 mm acc. to DIN 43 700; RAL 7021, dark grey

Ambient temp.: -20 to +65 °C

EMC: according to EC EMC directive 89/36/EEC

Interference emissions: EN 50081-2/EN 55 011 Class B

Interference resistance: EN 6100-6-2

Protection: NEMA4 / IP65 (front)

Weight: app. 50 g

Input: Thermocouple Sensor
J (Fe-CuNi)
K (Ni-CrNi)
N (NiCrSi-NiSi)
with sensor breakage monitoring

Control inputs: High: 4-30 V DC, Low: 0-2 V DC

Supply current: 1 mA

Supply line: 2-wire: max 20 Ω, programmable 3-wire, 4-wire: max 20 Ω, no balancing required

Temp. ranges: according to DIN IEC 584

J (Fe-CuNi)	-210.0 °C to +1200.0 °C
	-346.0 °F ... +2192.0 °F
K (Ni-CrNi)	-200.0 °C ... +1372.0 °C
	-328.0 °F ... +2501.6 °F
N (NiCrSi-NiSi)	-200.0 °C ... +1300.0 °C
	-328.0 °F ... +2370.0 °F

Resolution: 0.1°C (0.1°F) or 1°C (1°F)

Linearity error: < 0.4 % for entire measuring range at an ambient temperature of 20 °C

Cold junction error: ±1.0 °C typ. ±3.0 °C

Temp. drift: 0.1 K/Kambient

Wiring:

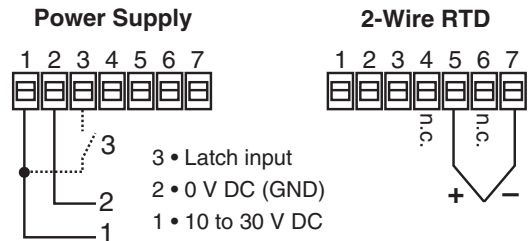

Order #:

532 = Temperature Display with thermocouple Input

Accessories

N7 - Explosion proof housing (see accessories section)

E200 - Outdoor Enclosure (see accessories section)

Panel Cutout: 0.876" x 1.78" (22.3 x 45.2mm)
or 0.99" x 1.97" (25 x 50mm) with adaptor provided

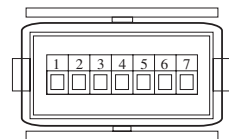
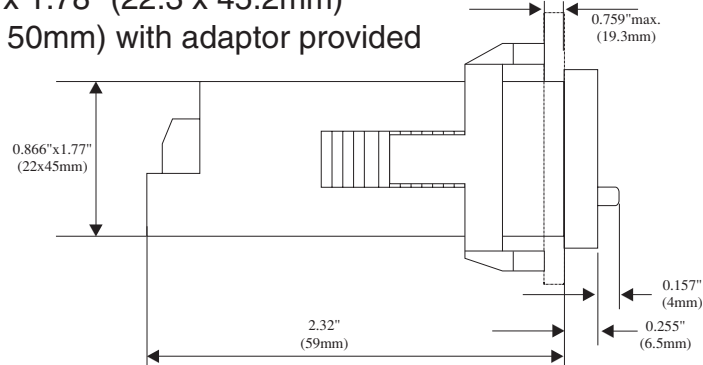
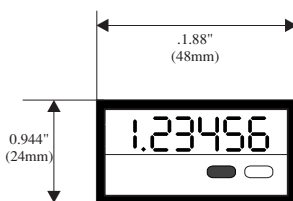

TP-554 Series

Temperature/Process Monitor With or Without Alarms

Features

- Very bright LED display, height 14mm
- DIN housing, 96 x 48 mm
- Programmable operating curve for standard signals, thermocouples, resistance thermometers, etc.
- Programmable operating curve, even non-linear, allowing the use of economical sensors
- Two relay outputs with two preset limit values

Additional features:

- DIN housing 96 x 48 mm
- Character height: 14 mm
- Resolution 14 bits
- Simple menu-driven programming, and operation with 4 keys
- Electrical connections by means of plug-in screw terminals
- Voltage supply: 10-30 VDC or 90-260 VAC
- IP 65/NEMA4 (front)
- Auxiliary power supply output for transducer or sensor
10..30 VDC: 10 VDC \pm 2%, 30mA
90..260 VAC: 24 VDC \pm 15%, 50mA and 10 VDC \pm 2%, 30mA
- Hum eliminator (50/60 Hz user selectable)
- Serial interface allows reading of the measured values and set-up programming.

Specifications:

- Display range: -19.999..99.999
- Input ranges:
0..400 Ω , 0..4000 Ω
0..100 mV, -100..+100 mV

Thermocouples

- Integrated operating curves for thermocouples (types B, C, D, E, G, J, K, L, N, R, S, T, U)
- Programmable input operating curve with up to 24 reference points
- 2 programmable limit values (TP551; unit without presets, has only 2 buttons)
- Outputs: Two (2) SPDT relays (250 VAC / 3A)
- Programmable hysteresis (on, off, on/off)
- SET key to reset the outputs
- Inputs: thermocouple, millivolt, resistance thermometer with measurement on 2, 3 or 4 wires, RESET to reset the outputs, KEY terminal to lock the front keys.



Dimensions:

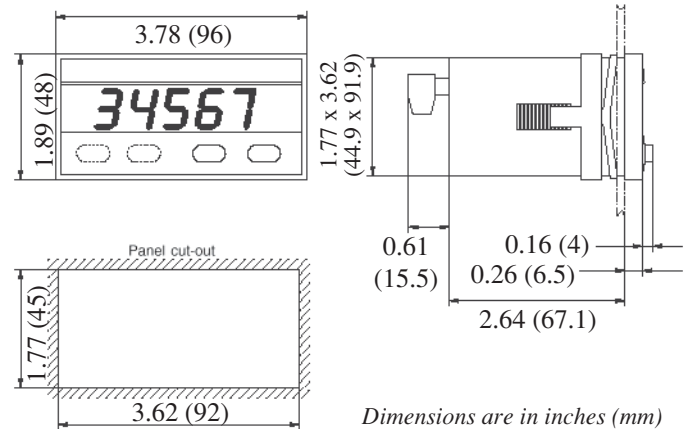

Wiring:

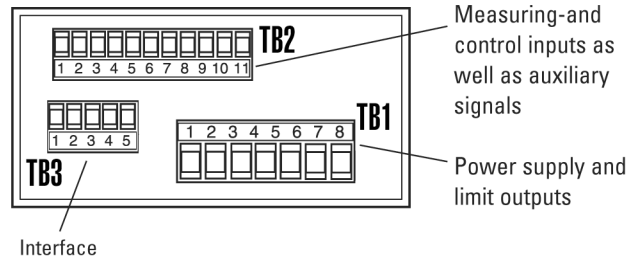

TB1			TB2		
1	Relay 2 Com. (Opto-Emitter)		1	Measuring input 1 (Sense)	
2	Relay 2 N.O.		2	Measuring input 2 (- Ref)	
3	Relay 2 N.C. (Opto-Collector)		3	Sensor (+Ref)	
4	Relay 1 Com. (Opto-Emitter)		4	Current output for 0 .. 4000 Ω (+ Sense)	
5	Relay 2 N.O.		5	Current output for 0 .. 400 Ω (+ Sense)	
6	Relay 2 N.C. (Opto-Collector)		6	Keys locking	
7	A.C. In (10-30 VDC)		7	Reference ground Reset / Key	
8	A.C. In (Ground; 0 VDC)		8	Reset	
			9	GND for DC Output (Pins 10 & 11)	
			10	+10 VDC Out (30 mA)	
			11	+24 VDC Out (50 mA) (AC units only)	

TB3			
	RS232	RS485	RS422
1	GND	-	-
2	RxD	DO+/RI+	RI+
3	TxD	DO-/RI-	RI-
4	-	-	DO+
5	-	-	DO-

Order Code

Example: TP554.010 0 00

Series: TP551.012 = No Presets/Relays
TP554.010 = 2 Presets/Relays

Operating Voltage:

0 = 90 to 260 VAC
3 = 10 to 30 VDC

Options:

00 = without interface
05 = RS232
06 = RS422
07 = RS485

BEACON Series

Low Cost Digital Panel Meters

Features

- AC / DC Voltage Inputs (Pos / Neg)
- AC / DC Current Inputs (Pos / Neg)
- AC or DC Supply Voltage
- NEMA 4X / IP65 Front
- Low / High Scaling
- 3^{1/2} Digit Display
- Over-Range Indication
- DC Output to Power Peripherals

Description:

The BEACON series is a bright new addition to KEP's product line. Featuring 3^{1/2} digits of bright RED or GREEN (optional) LED's, these meters outshine the competition by offering DIP switch selection of the most frequently used functions. The new BEACON series focuses on applications needing 3^{1/2} digits of display, showing -1999 to +1999 with switch selectable decimals. With their great flexibility and multiple input ranges, let the BEACON series digital panel meters be your guide.

Specifications:

Display: 3^{1/2} digit, .55" high, 7 segment bright LED. Minus sign displayed when current or voltage is negative. Decimal points inserted before 1st, 2nd, or 3rd least significant digits by DIP switch selection.

Power: Available in 5VDC, 8-24VDC, 115VAC or 230VAC ($\pm 10\%$). 260 mA (DC); 6 VA (AC).

Operating Temperature: +32°F to 130°F (0°C to 60°C)

Storage Temperature: -40°F to 200°F (-40°C to 80°C)

Output Power: (AC powered units only)

18 VDC regulated $\pm 4\%$ @ 50 mA

Input Ranges: (switch/jumper selectable)

AC & DC Volt Meters	AC & DC Current Meters
0-1.999 Volts	0-199.9 μ A
0-19.99 Volts	0-1.999 mA
0-199.9 Volts	0-19.99 mA
0-199.9 mV	0-199.9 mA
	0-1.999 amps (2A Option)

Over-Range Indication: Three least significant digits blank when input is over range.

Max. Voltage on Basic Range: 75 V AC/DC (terminals 4 & 5)

Max. Voltage on Terminal Block: 300 V AC or DC

Max Shunt Currents:

199.9 μ A through 19.99mA- 10 x (max. range current)

199.9mA- 1 amp

1.999 amp- 3 amps

Caution: A fast blow fuse should be installed in series with the current meter in applications where fault currents may exceed maximum allowable current.



Scaling:

Reference Adjust (supplied on all units)

Used to calibrate display to $\pm 30\%$ of STD input.

Span Adjust

Coarse and fine adjust pots offer $\div 1$ to $\div 13$ and when used with the switch selected ranges, offers direct readout of linear transducers.

"0" Offset Adjust

Sets "low" input display at $\pm 50\%$ of span.

Accuracy: (23°C, 85% R.H.)

(Add ± 2 digits to below for negative readings)

DC Volts- $\pm .1\%$ of Reading ± 1 digit

AC Volts- $\pm .1\%$ of Reading ± 3 digits

DC Current

199.9 μ A, 1.999mA, 19.99mA: $\pm .1\%$ of reading ± 1 digit

199.9mA: $\pm .18\%$ of reading ± 1 digit

1.999A: $\pm .1\%$ of reading ± 1 digit

AC Current

199.9 μ A, 1.999mA, 19.99mA: $\pm .1\%$ of reading ± 3 digit

199.9mA: $\pm .15\%$ of reading ± 3 digits

1.999A: $\pm .5\%$ of reading ± 3 digits

Temperature Coefficients:

Current Inputs

DC: ± 100 PPM/ $^{\circ}$ C

(1.999A: ± 200 PPM/ $^{\circ}$ C)

AC: ± 200 PPM/ $^{\circ}$ C

Voltage Inputs

DC: ± 75 PPM/ $^{\circ}$ C

AC: ± 150 PPM/ $^{\circ}$ C

Input Response Time: 1 second

Sample Rate: 3 samples/second

Normal Mode Rejection: 70dB 50/60Hz (DC units only)

Common Mode Rejection: 110dB DC or 50/60Hz (DC units only)

Case: Plastic case, NEMA 4X/IP65 front panel

Weight: 2 lbs.

Dimensions:

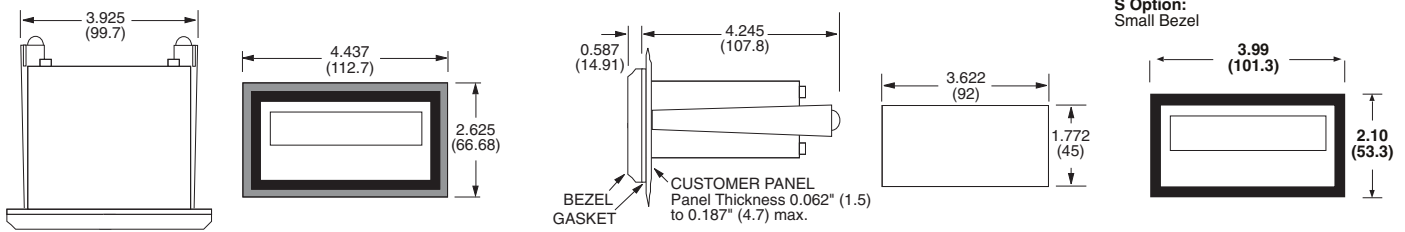

Switch S1 Functions:

- S1-1 Decimal Point XXX.X
- S1-2 Decimal Point XX.XX
- S1-3 Decimal Point X.XXX
- S1-4 Input Range 0-199.9 mV (Current Inputs)
- S1-5 Input Range 0-1.999 V
- S1-6 Input Range 0-19.99 V
- S1-7 Input Range 0-199.9 V
- S1-8 Current Shunt 0-199.9 μ A
- S1-9 Current Shunt 0-1.999 mA
(Current Shunt 0-19.99 mA: Jumper A)
(Current Shunt 0-199.9 mA: Jumper B)
(Current Shunt 0-1.999 A: Jumper C) (2A Option)
- S1-10 ON: DC input
OFF: AC input

Switch S2 Functions:

- S2-1 ON: "0" Low Input
OFF: Non "0" Input (Adj. P2)
- S2-2 ON: Non STD Input Range (Adj. P3 & P4)
OFF: STD Input Range
- S2-3 ON: AC Input
OFF: DC Input
- S2-4 ON: AC Input
OFF: DC Input

Potentiometer Function:

- P1: Display High Adj. (Ref)
- P2: Non "0" Input Adj. ("0" Offset) (S2-1 Must be OFF)
- P3: Non STD Input Adj. (Span) (Coarse) (S2-2 Must be ON)
- P4: Non STD Input Adj. (Span) (Fine) (S2-2 Must be ON)

Terminal Designations:

- P1 DISPLAY HIGH Adj. (ref)
- P2 NON "0" INPUT adj. ("0" offset)
- P3 NON STANDARD INPUT COARSE Adj. (span)
- P4 NON STANDARD INPUT FINE Adj. (span)

- 1• V/I HIGH INPUT
- 2• V/I HIGH INPUT COMMON
- 3• +18 VDC OUT (+DC POWER IN)
- 4• -DC OUT (-DC POWER IN)
- 5• EARTH GROUND
- 6• AC POWER
- 7• AC POWER

How To Order

Example **BC** **1** **DX** **G**

BEACON

Power:

- 1= 5VDC
 - 2= 8-24VDC (DC ranges jumper selectable)
 - 4= 115VAC
 - 5= 230VAC
- All ranges jumper selectable

Input:

- DS=DC Volt/Current display STD Input (no scaling)
- D0=DC Volt/Current scale from "0" only
- DX=DC Volt/Current scale with "0" offset
- A0=AC or DC Volt/Current scale from "0" only
- AX=AC or DC Volt/Current scale with "0" offset

Options:

- G= Green LED's
- S= Small Bezel (2.12" H x 4.01" W)
- 2A= 0 - 1.999 A input option
- 5A= 0 - 5 Amp input option

Accessories:

- BCAL1 = Descriptor Labels: %, °F, °C, Hz, kHz, RPS, V DC, mA DC, mV DC, V AC, mA AC, mV AC, μ A DC, A AC, A DC
- BCAL2 = Descriptor Labels: ft/sec, ft/min, ft/hr, ft³/sec, ft³/min, ft³/hr, GPM, GPH, RPM, in/sec, in/min, in/hr, lb/sec, lb/min, lb/hr
- BCAL3 = Descriptor Labels: L/sec, L/min, L/hr, m³/sec, m³/min, m³/hr, m/sec, m/min, m/hr, kpa, bar, kg, lb, PSI, kW
- BCR2A =External .1 Ω 1% 5W shunt (0 - 1.999 A)

BCSCALE = Custom Scaling
(Specify with each unit, see below)

Example: **Input** **IDC** **0.004** **0.020**
 Display **10.0** **150.0**

Where:

- IDC = DC Current, IAC = AC Current
- VDC = DC Voltage, VAC = AC Voltage
- Low Range 0.004 = 4 mA
- High Range 0.020 = 20 mA
- Low Display = 10.0
- High Display = 150.0

HVM-1

High Voltage Module for 5 to 240 VAC/VDC Input Signals

Features:

- Opto-Isolation up to 2500 V
- Allows units with 3-30 VDC inputs to Accept Inputs from 5 to 240 VAC or VDC
- Screw Terminal Hookup.
- Low Cost

Operation:

Connect the high voltage and the output as shown below. When pulsing with AC, be sure that the counter being driven by the HVM-1 is set for low speed inputs (usually 40 Hz or lower). If this is not done the counter will count each peak of the AC voltage.

Description:

The HVM-1 enables products with low DC (3-30V) inputs to accept 5-240 VAC/DC input signals. The unit mounts on the counter or customer panel with the use of double sided tape. The circuitry allows various voltage pulses to be used for counting and provides opto-isolation of 2500V.

SPECIFICATIONS:

Signal Inputs:

AC - 40 Hz max. (min. pulse width 12 msec.)

DC - 100 Hz max. (min. pulse width 5 msec.)

5 to 48 or 48 to 240 VAC/DC

Input Impedance:

5 to 48 V - 15K ohm

48 to 240 V - 100K ohm

Output

Voltage:

Off - 24 VDC max.

On - .7V @ 20 mA

Current: 20 mA MAX.

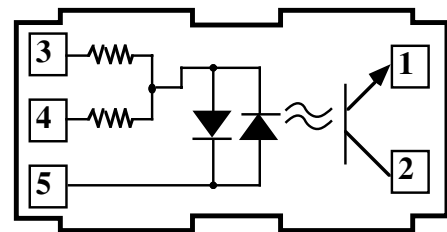
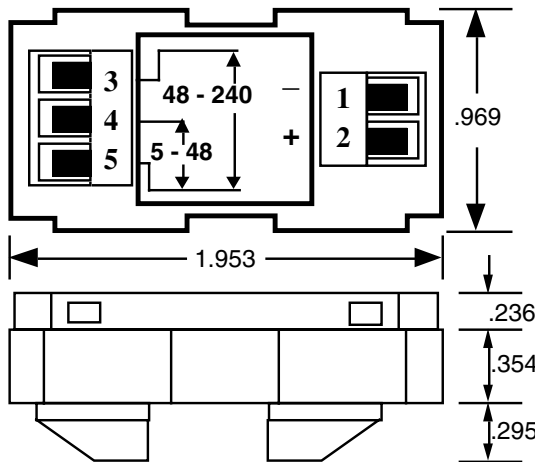

Typical Wiring:

MINITROL	KEPTROL KEPTROL R/T BATCHTROL II	INTELLECT SERIES
TERMINAL PIN #	TERMINAL PIN #	TERMINAL PIN #
5 and/or 6	3 and/or 4	4 and/or 5
7	13	7

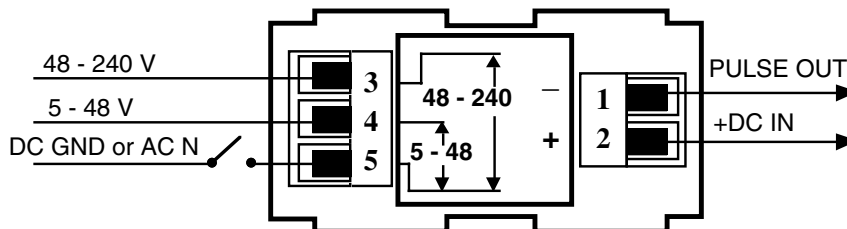

How To Order:

Part number	Description
HVM-1	High Voltage Module

KAL-DR/T

Dual Mode RPM/Counter or Frequency Meter

Features

- UL/CSA Listed, CE Certified
- Requires Only One Pulse Per Unit of Measure
- Doesn't Require Multi-Tooth Gears
- NEMA 4X / IP65 Front
- 5 Digit Ratemeter / 6 Digit Totalizer
- Low Cost
- RPM & Total



Application:

The KAL-DR/T measures the time between pulses (1/tau), It shows rate per minute (RPM) while keeping track of total units in an internal counter. An external connection causes a change from RPM to RPS (frequency) (No totalizer in RPS mode) No gears, no expensive inductive sensors - just a simple proximity switch sensing 1 pulse per revolution of the shaft - we do the rest!

Description:

The KAL-DR/T monitors both rate and count continuously and simultaneously. While the display is indicating units per minute, a "background" totalizer keeps count of events or items. A pushbutton on the front panel toggles the display between rate and count and is also used to reset the count (by holding it pressed for 3 seconds)

An alternative gated mode of operation is available to measure signal frequency.

Maximum rate is 20000 in the RPM mode, or 50 kHz in the frequency mode. Connections are made via push on wire connectors for easy field installation. KAL-DR/T has a 6 digit, 0.276" high display and meets NEMA 4X standards from the front panel. It does not have a battery, so it must be powered from an external 10-30 VDC source.

SPECIFICATIONS

Power: (Pin 5) 10 to 30 VDC, 10mA

Display: 6 digit black LCD

Digit size 0.276" high

Temperature Range: + 14 to 140°F (-10 to 60°C)

Sealing: Front panel sealed to NEMA 4X

Connection: 5 pin, plug in connector with 9" leads supplied with meter.

Accuracy:

Period: 0.18%; 3 to 20K RPM.

Gated: ± 1 LSD 1 to 50K RPS

Signal Inputs:

Slow Speed Input (Pin 2):

negative edge triggered

Low: < 0.7V, High: 5 to 18 V or open

Max. speed: 30 Hz, Min Pulse 15 mS

Input Impedance: 1 M Ohm

High Speed Input (Pin 4):

negative edge triggered

Low: < 0.7V, High: 5 to 18 V or open

TTL and CMOS compatible

Input Impedance: 1 M Ohm

Update Time 2 sec. (min.) to 18 sec. (max.) depending on period.

Period (RPM) Mode:

Max. speed: 333 Hz, Min. pulse 1.5 mS (3 to 20K RPM)

Gated (Frequency) Mode:

Max. Speed: 50 kHz, Min. Pulse 10 μ S (1 to 50K RPS)

Period/Gated Mode Select (Pin 3):

Linked to Pin 1: Frequency Meter

Left Open: RPM Meter

Totalizer:

999999 maximum display (333 Hz maximum input speed)

Approvals: UL File - E135458, CSA File - LR96702,
CE Approved

Material: ABS

Weight: 1.7 oz.

Typical Hookup:

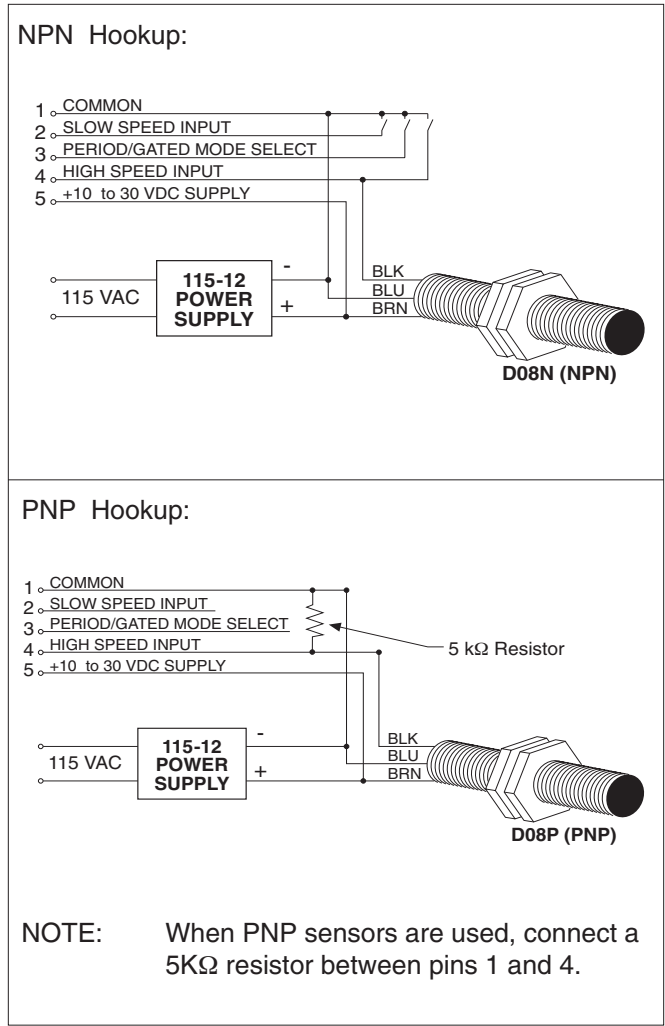

Mounting:

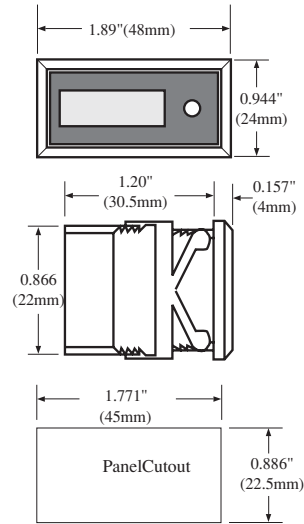

**Adaptors (included)
KAL-DP1X2**

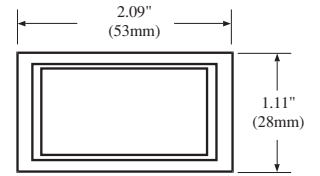

KAL-DP1

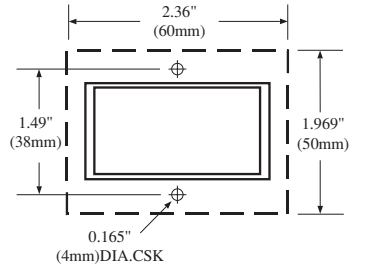

Our D Series Proximity Sensors interface easily with our full line of counters and ratemeters. Use PNP sensors (D_P) on all KEP units except KAL Series, which requires D_N (NPN) sensors. (See Sensors & Accessories Section)

HOW TO ORDER

Part Number	Description
KAL- DR/T	Ratemeter with Totalizer
KAL - DTB	Terminal block adaptor

Accessories

- 115-12 - 12 V Power Supply (see accessories section)
- N7 - Explosion proof housing (see accessories section)
- E200 - Outdoor Enclosure (see accessories section)

136K

Battery Powered Ratemeter with LCD Display

Features

- Low price and high efficiency
- Large (8 mm) 8-digit LCD display,
- Optional backlighting
- Input frequency range from 1 Hz ... 12 kHz
- Gate measuring method, gate time 1 second
- Accuracy 0.05%
- High voltage input for 10 to 260 V AC/DC voltage pulses
- NEMA4/IP65 Front Panel
- Screw terminals, RM 5 mm



- Lifetime of the battery approximately 8 years
- Operating temperature -10 to +60 °C
- All versions for positive or negative counting edge

Technical data

Power supply: non-replaceable lithium battery: (lifetime approximately 8 years at 20°C)

Backlighting: external electrical source 24V DC +/-20%, 50 mA

Display: LCD, 8 decades, 8 mm high characters

Display range: 0 ... 99999999

Resolution: 1/sec (1 Hz)

Inputs:

A. Counting input of the DC-versions (max. 30 V DC)

Slow counting input: max. 30 Hz NPN

Fast counting input: max. 12 kHz (PNP), 7 kHz (NPN)

Switching level:

NPN: Low: 0 -0.7V, High: 3-30V DC

PNP: Low: 0 -0.7V, High: 4 -30V DC

Interference emissions:

EN 55011 Class B, EN 61000-6-2

EN 61010 Section 1 (only AC versions)

Operating temperature:

-10 ... +55 °C

Ambient temperature:

-10 ... +60 °C

Storage temperature:

-20 ... +70 °C

Protection: NEMA4/IP65 front

Weight: approximately 50 g

Dimensions:

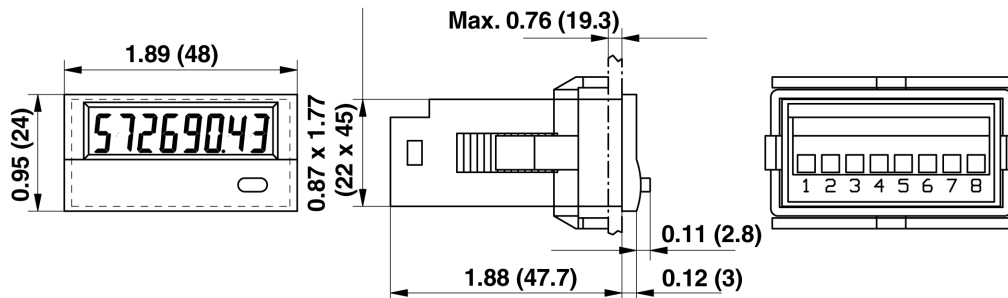

Order Table

Type	Mode	Counting inputs					
		INP A			INP B		
136K.012.8x0	Tacho	0 ... 0,7 V DC	NPN	7 kHz	0 ... 0,07 V DC	NPN	30 Hz
136K.012.8x1		4 ... 30 V DC	PNP	12 kHz	4 ... 30 V DC	PNP	

X: 5 = no backlight
X: 6 = with backlight

Accessories

N7 - Explosion proof housing (see accessories section)
E200 - Outdoor Enclosure (see accessories section)

PROTROL

Draw, Ratio & Net Ratemeter

Features

- 2 Separate Dividing Scale Factors for Inputs A & B
- 2 Set Points Each With a Hysteresis Alarm Range
- Displays Three Separate Values; A (A Rate), B (B Rate) & C (A-B), (A÷B) or [(A-B)÷B]
- Digital Input Up To 10kHz
- NEMA 4X / IP65 Front
- 2 Stage Panel Lockout
- RS232 or RS422 Communications

Description:

Featuring 6 digits of bright, 7-segment LED displays, the Protrol is a rate, ratio and draw meter which is field programmable. The two inputs (A & B) each have separate scaling factors. The unit can be programmed to display: two separate ratemeters (A & B), the net difference of A & B, the ratio of A to B (A ÷ B) or the draw [(A - B) ÷ B]. Two assignable set points are standard with a programmable hysteresis (alarm range).

Specifications:

Display

5 digit, .55" high, 7 segment, red orange, LED.

Input Power: 110 ± 15% or 12 to 15VDC; 220 VAC ± 15% or 12 to 15VDC.

Current: maximum 250 mA DC or 6.5 VA at rated AC voltage.

Output Power: (AC powered units only) + 12VDC @ 50mA unregulated -10 +50%

Temperature:

Operating: +32°F (0°C) to +130°F (+54°C).

Storage: -40°F (-40°C) to +200°F (93°C).

Memory: EEPROM stores data for ten years if power is lost.

Reset:

Front Panel: Resets (updates) normalization process.

Remote: Resets control output (if it's in hysteresis and below the preset).

Control Outputs:

2 each N.O. Relay - 5 Amp @ 120/240 VAC or 28 VDC. (N.C. Relay contacts or NPN sink from 10VDC to .5V @ 100mA available with solder jumpers).

Input:

STD: High Impedance. Open or 0 to 1V (low), 4 to 30V (high) 10K Ohm impedance. 9.99 kHz max. input speed. OPTION "M": For Magnetic pickup Inputs, accepts 30mV inputs



Set Points: Two control set points are provided. The outputs have a programmable hysteresis alarm range from 0 to 99999

Rate Display: The ratemeters (A&B) update once per second and are accurate to 0.01% FS (± 1 display digit). The unit will sample from 2 to 24 seconds and will compute a weighted average (normalization).

Programming: Set points, decimal points, Scaling from .0001 to 99999, input type, normalization factor, hysteresis alarm range, and security panel lock code are all programmable from the front panel.

Housing: Standard 1/8 DIN, high impact ABS plastic case (NEMA 4X / IP65 front panel).

Shipping Weight: 2 lbs.

Approvals: CE Approved

Terminal Designations:

- 1- COMMON
- 2- N.O.(N.C./NPN)
- 3- COMMON
- 4- N.O.(N.C./NPN)
- 5- A INPUT
- 6- B INPUT
- 7- 12VDC OUT/+DC IN
- 8- -DC (GROUND)
- 9- RESET INPUT
- 10- NOT USED
- 11- A.C. INPUT
- 12- A.C. INPUT

RATE INDICATORS

Protrol Application:

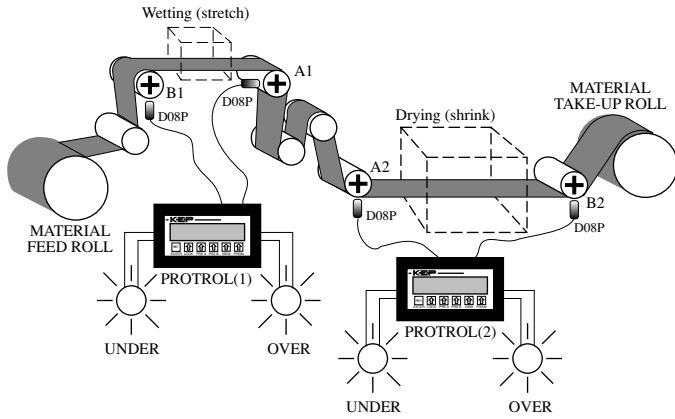

This application involves the process of shrinking material for pre-shrunk jeans. The process involves the wetting/stretching and drying/shrinking of the material. The KEP Protrol allows the operator to view the rate of the input and output feeds (displays A & B). A third display (display C) allows the user to view A-B, A+B or (A-B)÷B. In this application Protrol(1) monitors the wetting/stretch and Protrol(2) monitors the drying/shrink. The wetting process must maintain a 2.4% stretch and the drying process must maintain a 3.2% shrink. Both the wetting and drying functions must have over and under detection if the process exceeds or lags by .1%. For each Protrol there is an over detection lamp and an under detection lamp.

Here's how the Protrol's are set up. Each roller (excluding the feed and take-up rolls) are one foot in circumference. Since there are four targets per rotation, there are four pulses per foot. Therefore, the scaling factors are all set at four. The C display is selected to view (A-B)÷B. Both Protrols were field modified for a normally closed (N.C.) B relay.

Protrol(1):

Typically, B1 rotates at 25 RPM and A1 at 25.6 RPM. This yields a 2.4% stretch ($[(25.6-25) \div 25] \times 100 = .024$). Preset A is set at .025 and preset B is set at .023 (to maintain a .1% tolerance). Relay A is wired to the over detection lamp and relay B is wired under detection lamp.

Protrol(2):

Typically, B2 rotates at 24.8 RPM and A2 at 25.6 RPM. This yields a 3.2% stretch ($[(25.6-24.8) \div 24.8] \times 100 = .032$). Preset A is set at .033 and preset B is set at .031 (to maintain a .1% tolerance). Relay A is wired to the over detection lamp and relay B is wired under detection lamp.

Now the operator can view the input and output speeds of the wetting and drying cycles, as well as the amount of stretch and shrink. The warning lamps let the operator know if there is a problem prior to the process or after the process.

NOTE: To view the C display in percentage (X100), order MS280.

Dimensions:

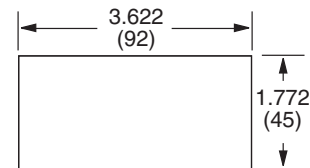
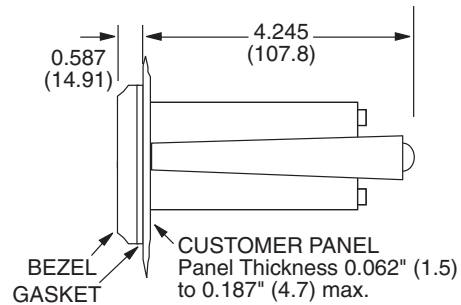
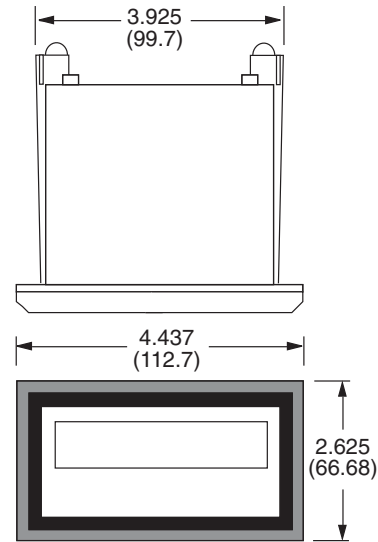

HOW TO ORDER

EXAMPLE: PR A 1

Series PR = Protrol

Operating Voltage

A = 110 VAC ± 15% or 12 to 15 VDC
B = 220 VAC ± 15% or 12 to 15 VDC
C = 24 VAC ± 15% or 12 to 15 VDC

Options

1 = RS232 Communications
2 = RS422 Communications
M = Mag. Input, Input A & B, 30mV input
A = Analog Output (4-20/0-20 mA)

Accessories

Separate non keyboard panel order #34235
 Separate keyboard panel - order #34237

5800 Series

Incremental Shaft Encoder

Features:

- Low Cost
- Short Circuit Resistant Outputs
- Rugged Design to Industry Standard
- Low Power Consumption
- Shock Resistant



Mechanical Characteristics

Speed:	max. 6000 RPM (12000 RPM above 600 PPR)
Rotor Moment of Inertia:	$1.8 \times 10^{-6} \text{ kgm}^2$
Torque:	<0.01 Nm
Radial Load Capacity of Shaft:	20 N (at shaft end)
Axial Load Capacity of Shaft:	10 N
Weight:	Approx. 0.4 kg
Protective System to DIN 40.050:	Shaft IP64, Cover (IP50 w/ connector)
Operating Temperature Range:	0° C to +50° C (-20 °C to 70°C above 600 PPR)
Shaft:	Stainless Steel

Electrical Characteristics

Output Circuit:	Push-Pull Circuit
Supply Power:	10-30 VDC
Current Consumption: (no load)	max. 50 mA (75 mA with reference)
Permissible Load / Channel:	max. $\pm 30 \text{ mA}$
Pulse Frequency:	max. 20 kHz (100 kHz above 600 PPR)
Signal Level High @ 30 mA:	Supply Voltage minus 2.5V (7.5 to 27.5V)
Signal Level Low @ 30 mA:	max. 1.5V
Signal Level Low @ 1 mA	max. .7V
Rise Time:	max. 1 μS
Fall Time:	max. 1 μS
Short Circuit Proof Outputs:	yes
Standard Pulses Per Revolution	60, 250, 600
Available Pulses per Revolution	10, 20, 30, 40, 50, 60, 80, 96, 100, 120, 125, 127, 150, 180, 200, 216, 220, 240, 250, 254, 256, 280, 300, 314, 360, 400, 420, 450, 500, 512, 600, 625, 720, 750, 800, 900, 1000, 1024, 1250, 1270, 1400, 1500, 1800, 2000, 2048, 2400, 2500, 3000, 3600, 4000, 4096, 5000

Other Pulses Per Revolution available upon request Consult Factory

Approvals: CE

Pulse Pattern

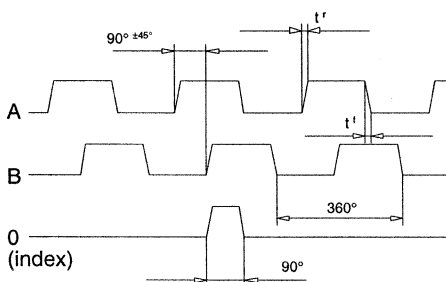

Direction of Rotation

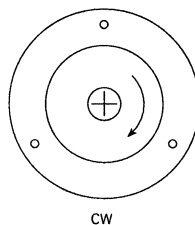

Output Circuit

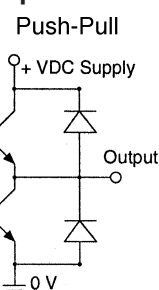

Dimensions:

Flange 2: synchronous flange dimensions are in inches (mm)

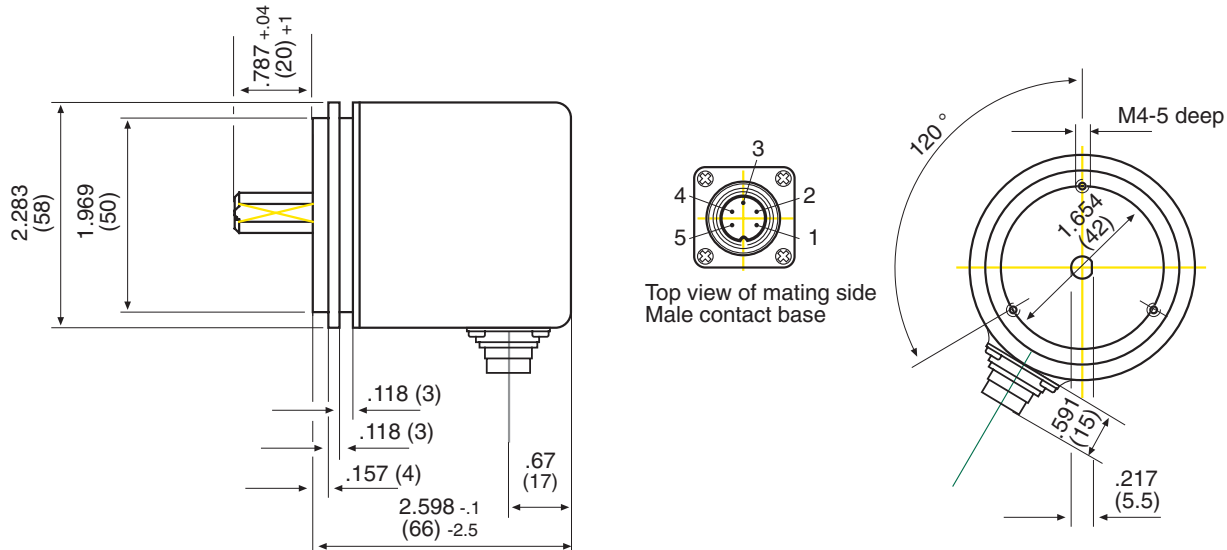

5810AM1: Angle Bracket dimensions are in inches (mm)

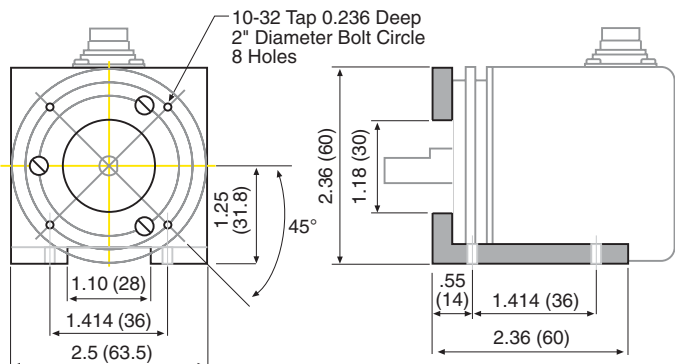

How To Order:

Example 5810 2 3 1 6 0250

Series	_____				
Range	_____				
2 = synchronous flange					
Shaft (D x L)	_____				
3 = .250" x .79" (6.35mm x 20mm)					
4 = .375" x .79" (9.53mm x 20mm) [bushing for .250 dia.]					
5 = .394" x .79" (10mm x 20mm) [bushing for .250 dia.]					
Version	_____				
1 = channel A					
2 = channels A + O (Special Order)					
3 = channels A + B					
4 = channels A + B + O (Special Order)					
Type of Connection	_____				
5 = connector radial without mating connector					
6 = connector radial with mating connector					

Terminal assignment:

Pin#	Signal
1	0V (-DC)
2	+DC
3	A
4	B
5	O
*	Ground

* Ground is connected to housing.

Pulse Per Revolution

(STD for Quick Delivery: 0060, 0250,0600)
 Price Break per PPR
 0001-0250
 0251-0600
 0601-1500
 1501-2500
 2501-5000

Accessories

5810AM1= Angle Mount Bracket 2.5"
 5810AB.375= .250" x .375"mm Bushing
 5810AB10= .250" x 10mm Bushing
 5810AC= Mating Connector 5810/9010

9000 Series

Incremental Shaft Encoder

Features:

- Low Cost
- Short Circuit Resistant Outputs
- Rugged Design to Industry Standard
- Low Power Consumption
- Shock Resistant



Mechanical Characteristics

Speed:	max. 6000 RPM
Rotor Moment of Inertia:	$15 \times 10^{-6} \text{ kgm}^2$
Torque:	<0.05 Nm
Radial Load Capacity of Shaft:	70 N (at shaft end)
Axial Load Capacity of Shaft:	35 N
Weight:	Approx. 1.2 kg
Protective System to DIN 40.050:	Shaft IP66, Cover (IP50 w/ connector)
Operating Temperature Range:	0° C to +50° C (-20° C to 70° C above 600 PPR)
Shaft:	Stainless Steel

Electrical Characteristics

Output Circuit:	Push-Pull Circuit
Supply Power:	10-30 VDC
Current Consumption: (no load)	max. 50 mA (75 mA with reference)
Permissible Load / Channel:	max. $\pm 30 \text{ mA}$
Pulse Frequency:	max. 20 kHz (100 kHz above 600 PPR)
Signal Level High @ 30 mA:	Supply Voltage minus 2.5V (7.5 to 27.5V)
Signal Level Low @ 30 mA:	max. 1.5V
Signal Level Low @ 1 mA	max. .7V
Rise Time:	max. 1 μS
Fall Time:	max. 1 μS
Short Circuit Proof Output:	yes
Standard Pulses Per Revolution	60, 250, 600
Available Pulses per Revolution	96, 100, 120, 125, 127, 150, 180, 200, 216, 220, 240, 250, 254, 256, 280, 300, 360, 400, 420, 450, 500, 512, 600, 625, 720, 750, 900, 1000, 1024, 1250, 1270, 1500, 1800, 2000, 2048, 2400, 2500, 3000, 3600, 4000, 4096, 5000

Other Pulses Per Revolution available upon request Consult Factory

Approvals: CE

Pulse Pattern

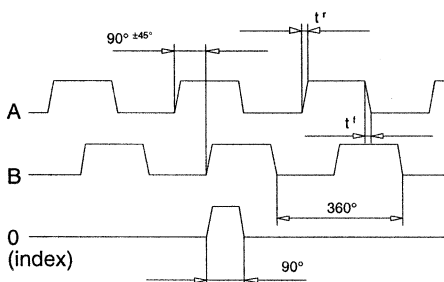

Direction of Rotation

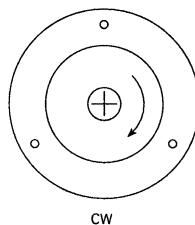

Output Circuit

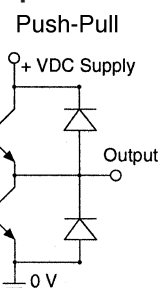

Dimensions:

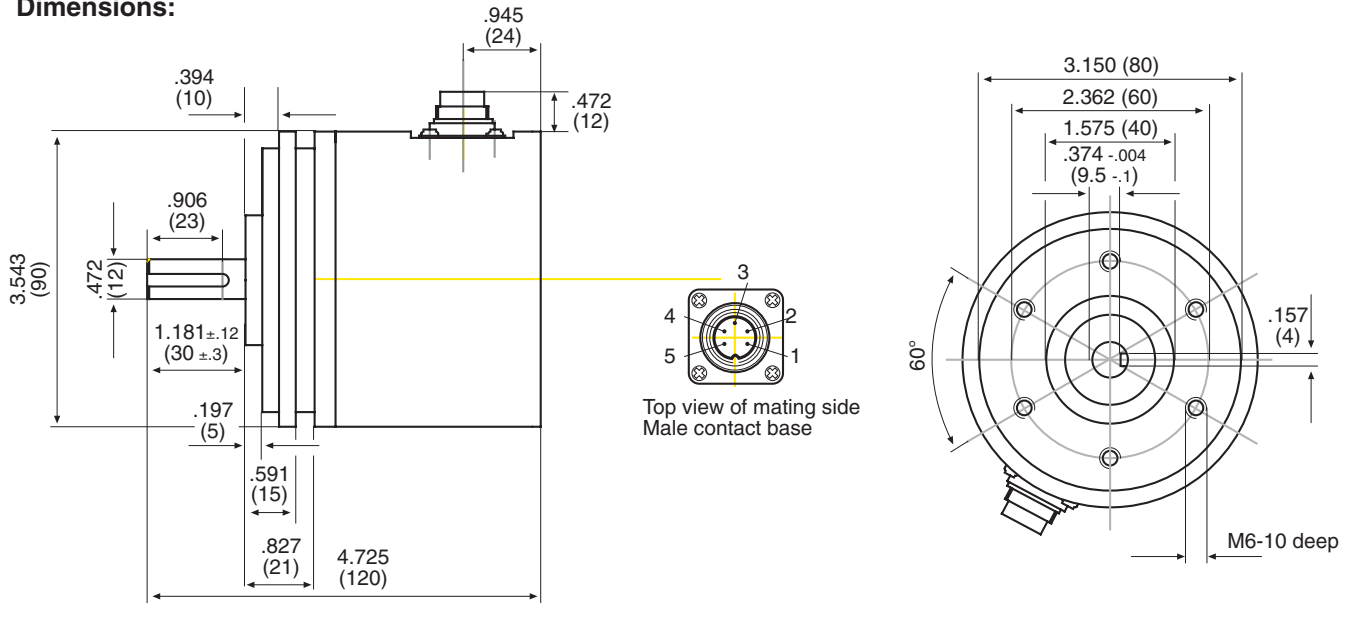

9010AM1: Angle Bracket dimensions are in inches (mm)

Terminal assignment:

Pin#	Signal
1	0V (-DC)
2	+DC
3	A
4	B
5	O
*	Ground

* Ground is connected to housing.

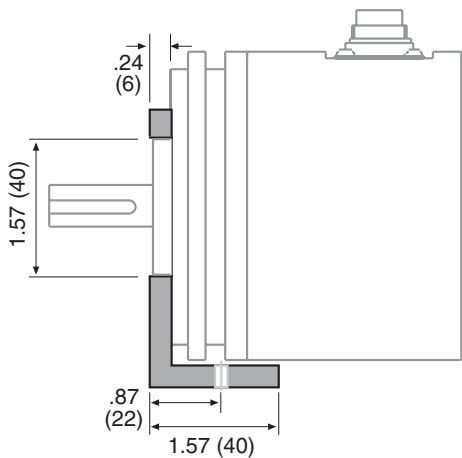
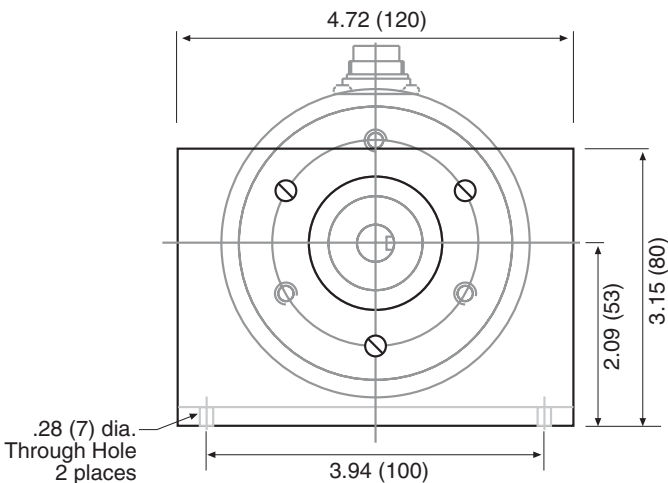

How To Order:

Example 9010 1 3 1 6 0250

Series

Range

1 = synchronous flange

Shaft (D x L)

1 = .472 x 1.18 (12mm x 30mm)

Version

- 1 = channel A
- 2 = channels A + O (Special Order)
- 3 = channels A + B
- 4 = channels A + B + O (Special Order)

Type of Connection

- 5 = connector radial without mating connector
- 6 = connector radial with mating connector

Pulse Per Revolution

(STD for Quick Delivery: 0060, 0250, 0600)

Price Break per PPR

- 0001-0250
- 0251-0600
- 0601-2000
- 2001-5000

Accessories

- 9010AM1= Angle Mount Bracket 4.7" x 1.6"
- 5810AC= Mating Connector 5810/9010

200 Series

Hollow Shaft Encoder

Description:

MODEL 230 - BI-DIRECTIONAL

The Model 230 Optical Encoder is designed to mount directly on a shaft for bi-directional applications. The encoder produces two symmetrical 50% duty cycle square wave output signals in quadrature relationship to each other. The signals lead or lag each other by 90 degrees depending upon the direction of rotation.



Specifications

Model 230

ELECTRICAL INPUT

Voltage	5 to 16 VDC (specify)
Current	50 Milliamperes
Regulation	±10%

ELECTRICAL OUTPUT

Wave shape	Square Wave
Rise Time	Less than 1 microsecond
Current	Sink 20 milliamperes/output
Pulse rate	0 to 6000 Hz
Pulses per shaft revolution	1 to 100 (specify)

MECHANICAL

Hollow shaft speed	4000 RPM maximum
Hollow shaft rotation	Either direction
Bearings	Sealed ball bearings
Bore size250"(6.35mm) to .875"(22.22mm) dia. (spec)
Bore tolerance	+.003"(.076mm)-.000"(.000mm)
Running torque	10 oz. inches (40.5gm-cm)
Operating life	100,000 hrs.
Housing	Alum. black anodized finish
Cable	Two 3 conductor shielded, 6 ft. long w/ built-in strain relief
Weight	8 oz. (227 grams)

ENVIRONMENTAL

Temperature	+32°F (0°C) to +167°F (+75°C)
-------------------	-------------------------------

Typical Application:

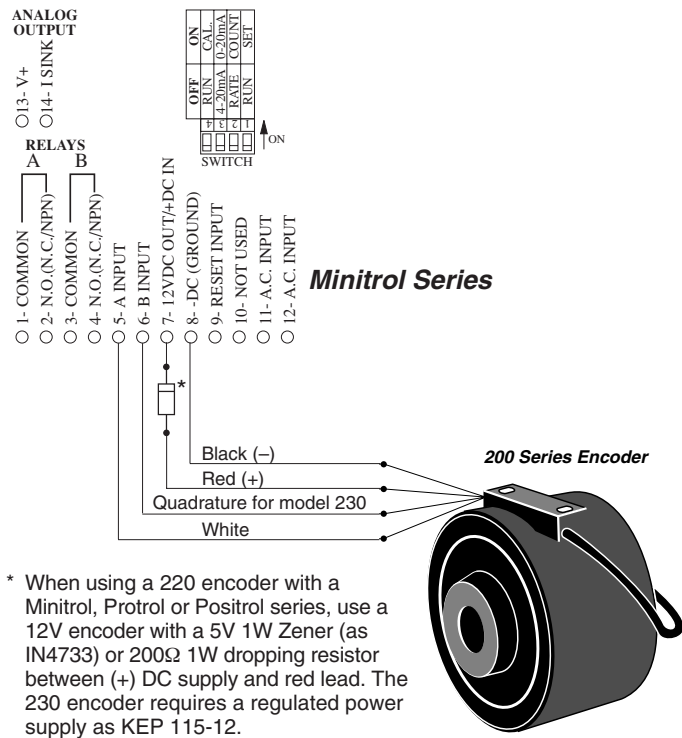

Mounting:

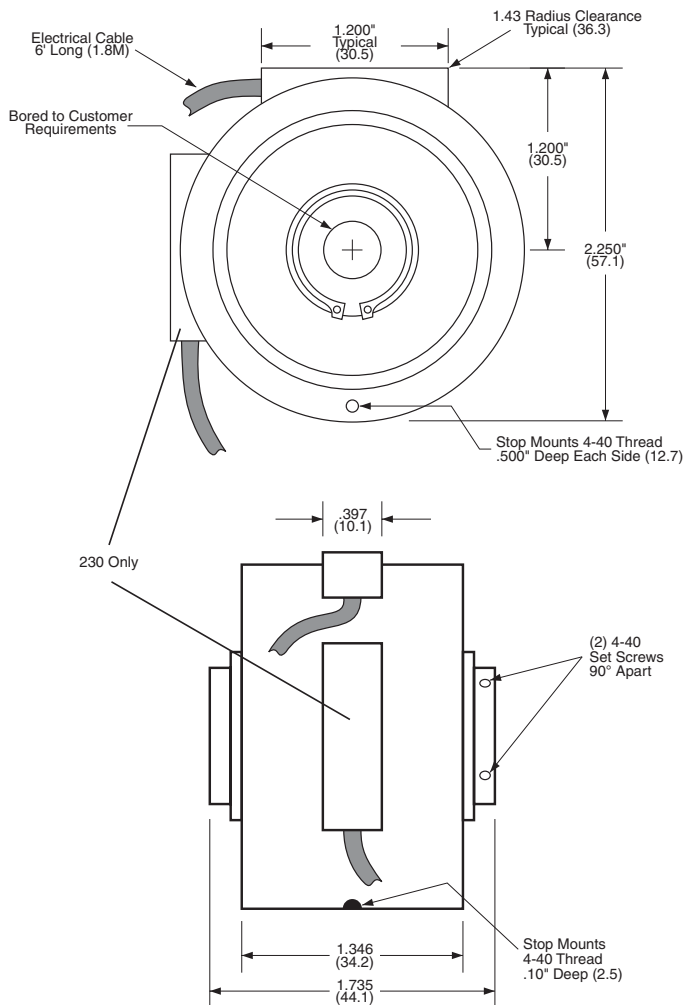

Circuit Diagram Per Channel:

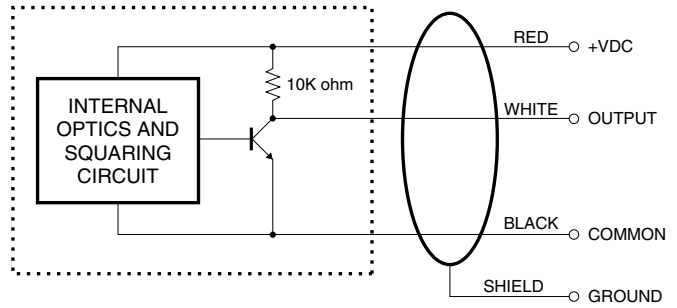

A flexible housing stop must be provided to prevent improper bearing wear and overheating. Please do not mount outer housing rigidly.

How To Order:

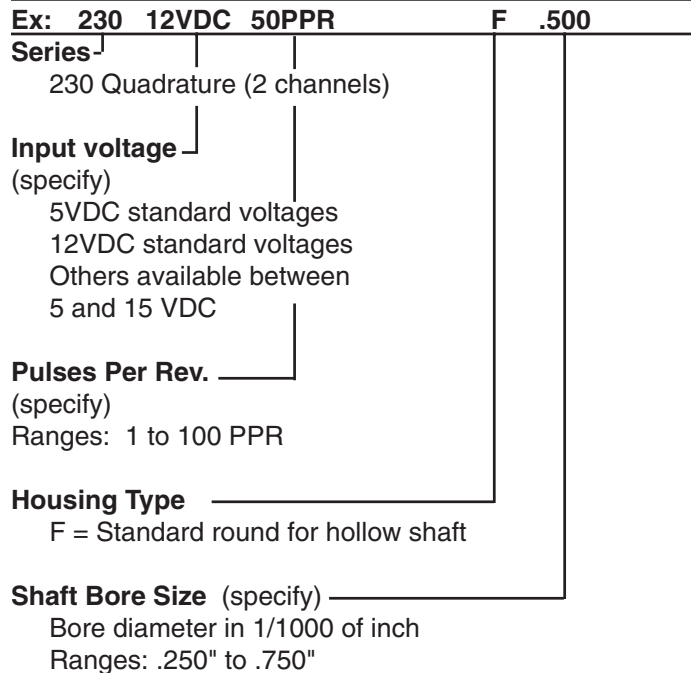

700 Series

Optical Shaft Encoder

DESCRIPTION:

The 700 optical incremental shaft encoders convert input shaft rotation into square wave output pulses to provide an accurate means of digitizing position, rate or direction of rotation. They are designed specifically for industrial applications requiring a rugged and reliable shaft encoder that is sealed against dust, oil vapor and moisture.

The shaft encoder produces an output signal by rotating a shatter-proof plastic disc with clear and opaque segments between a light emitting diode and a photo-transistor sensor. The output signal from the sensor is then converted into a square wave signal by an internal squaring circuit. The number of output pulses per shaft revolution is determined by the number of clear and opaque segments on the disc. Bidirectional models have a second LED and sensor positioned to produce two square wave signals in quadrature.

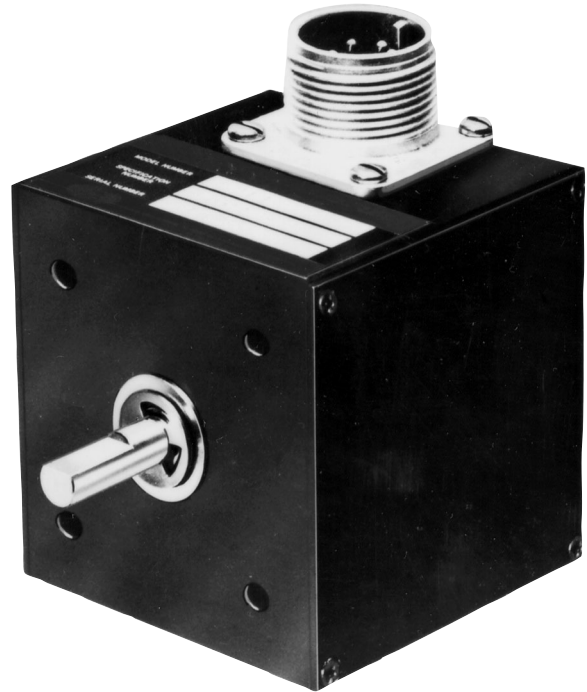

SPECIFICATIONS:

ELECTRICAL SPECIFICATIONS

INPUT:

Voltage5 VDC, or 8 to 30 VDC (Specify Choice)
Current50 mA \pm 10%
Ripple2%
Regulation \pm 5%

OUTPUT

Amplitude80% of input voltage (min.)
CurrentSink up to 20 milliamperes (10 milliamperes on multi-output units). 1.5K pull up to input voltage
PolarityPositive
Wave ShapeSquare wave, 50% "on" and 50% "off"
Pulse Rate0 to 20,000 pulses per second
Rise TimeLess than 1 microsecond
Pulses per Rev.1 to 1270 (Specify choice)
AccuracyWithin \pm 0.1 degrees from one pulse to any other pulse.

ENVIRONMENTAL SPECIFICATIONS

Temperature0 to 75 degrees C (+32°F to 167°F)
Vibration3 g's at 5 to 1000 CPS
Shock20 g's, 10 milliseconds

MECHANICAL SPECIFICATIONS

Shaft Speed6,000 RPM maximum
Shaft RotationEither direction
BearingsSealed ball bearings
Starting Torque0.10 ounce-inches
Moment of Inertia0.0025 ounce-inches seconds squared
Radial Loading10 pounds operating
Axial Loading5 pounds operating
Shaft Size250" or .375" diameter (Specify choice)
Shaft TypeSingle or double ended (Specify choice)
Operating Life100,000 hours average
HousingAluminum with black anodized finish. Sealed against dust, oil vapor and moisture.
MountingProvisions for either base or face mounting
WeightA-10 oz., B- 3.75 lbs., C- 3.25 lbs., D- 6 lbs.
Connector Type6-pin MS Connector or Solder Terminals

A HOUSING

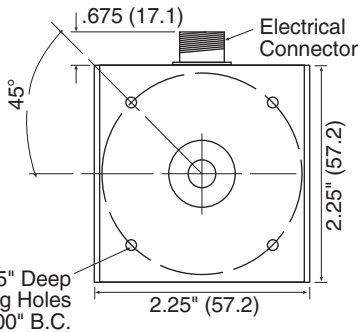
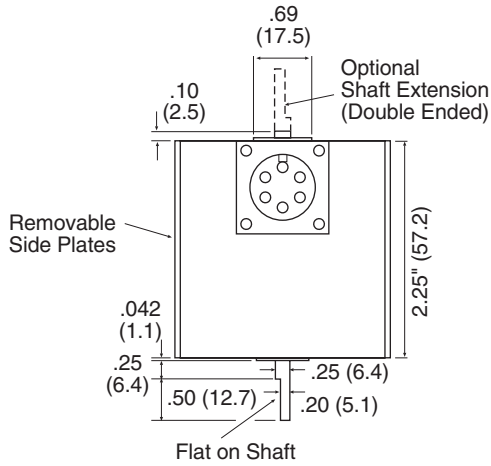

The same mounting hole pattern is also provided on the opposite end and the base.

B HOUSING

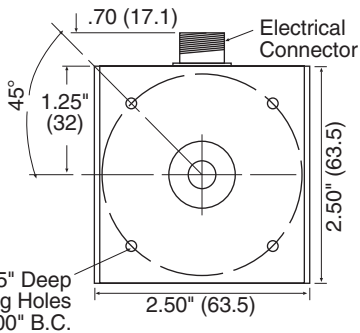
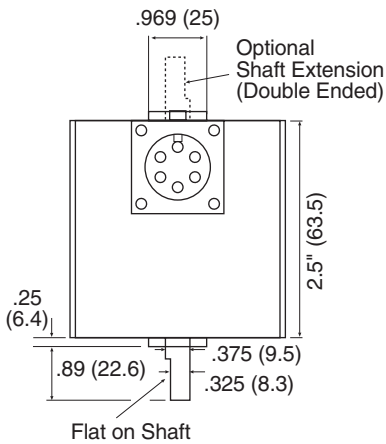

The same mounting hole pattern is also provided on the opposite end and the base.

C HOUSING

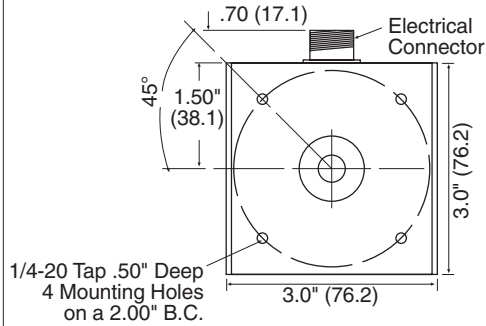

The same mounting hole pattern is also provided on the opposite end and the base.

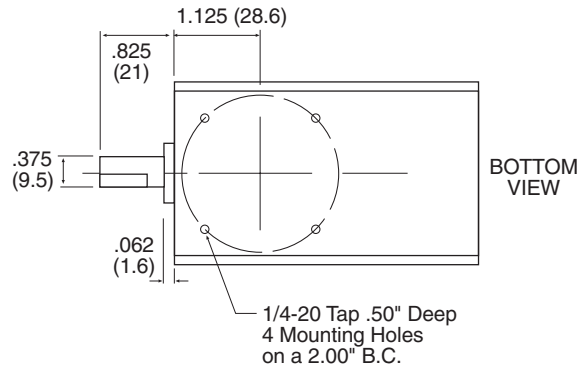
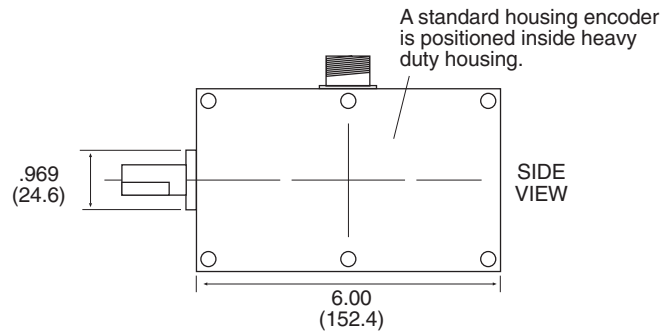

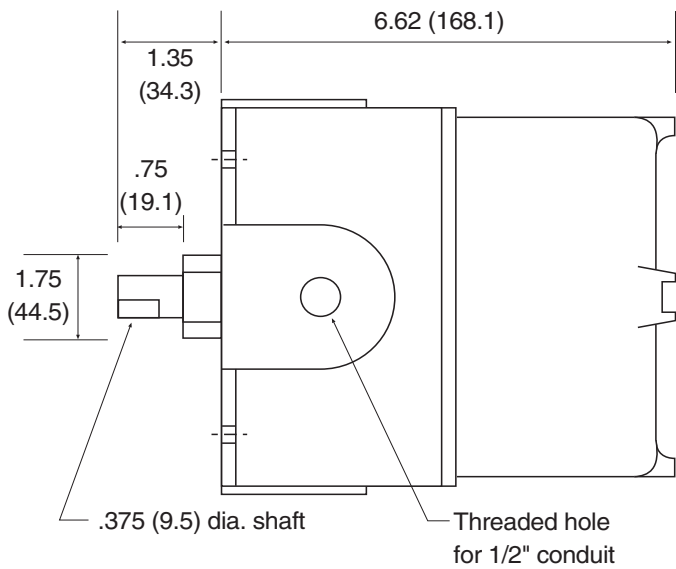
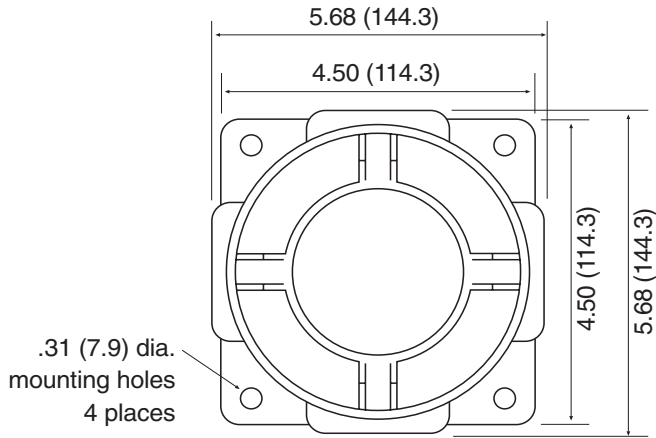

WIRING

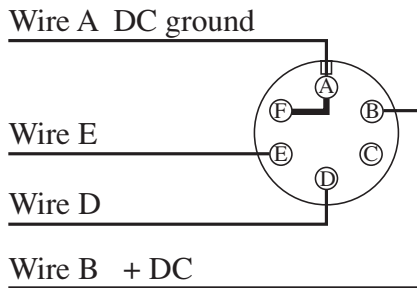

Encoder Model #	Wire D	Wire E
711	pulses	N/C
715-1	CW pulses	CCW pulses
715-2	pulses	hi-cw/lo-ccw
716	Quad "A"	Quad "B"
717	pulses	N/C

Type

Order Number

Single Channel **711 12VDC 600PPR A1**
 Square Wave Pulse **711 12VDC 1200PPR A1**

Dual Channel **716 12VDC 600PPR A1**
 Quadrature **716 12VDC 1200PPR A1**

How To Order Special Encoders:

EX: 715-1 12VDC 200PPR 50US 500RPM A1 L2.3

Series
 711 (Single Square Wave Pulse)
 712 (711 with Reference Pulse)
 713 (2 Different Square Waves)
 *715-1 (Bi-Directional; 2 Channels)
 *715-2 (Bi-Directional; 1 Channel plus direction)
 716 (Quadrature)
 *717 (High Resolution 711l)

Input Voltage

5 VDC
 12 VDC
 15 VDC
 24 VDC

Pulses Per Rev. Over 600PPR

(Model 713 ex.: 100/200 PPR)

***Pulse Width (if required)**

ms = milliseconds
 us = microseconds

Shaft Maximum RPM (specify)

Housing Type

- A. Standard
 - A1. Single Shaft
 - A2. Dual Shaft
- B. Industrial:
 - B1. Single Shaft
 - B2. Dual Shaft
- C. Heavy Duty Housing:
 - C1 (with mating connector)
 - C2 (with mating connector & shaft seal)
 - C3 (with 1/2" conduit thread & terminal strip)
 - C4 (with shaft seal, 1/2" conduit thread & terminal strip)
 - C5 (extra heavy duty up to 50lb. radial load : 10mm shaft)
- D. Explosion Proof
 (Class 1, Groups C & D / Class 2 Groups E, F, G / NEMA 7 & NEMA 9)

Other Options

- L- Custom Shaft
- B - 3/8" shaft option
- ENC MS: Extra mating connector
- ENC-CABLE##: Extra mating connector with 4-conductor cable
- Reference Pulse - Add 1N (neg. pulse) or 1P (pos. pulse) after PPR

See the following page for Mounting Brackets and Measuring Wheels.

ENCODER ACCESSORIES



MEASURING WHEELS			
1 FOOT (304.8mm) CIRCUMFERENCE		1/3 METER(13.12" CIRCUMFERENCE	
Bore	.251 (6.38mm) ID		Bore .251(6.38mm) ID
Face Width	1/2" (12.7mm)	1" (25.4mm)	Face Width 1/2" (12.7mm)
Rubber	15537-070	15537-530	Rubber 407186-009
Smooth	15537-095	15537-525	Smooth 407186-010
Knurled	15537-510	15537-535	Knurled 407186-011
Grooved	15537-187		
For 3/8" bore add 3/8 to end of part number			

ENCODER BRACKET

Plate Mount Model 7005

Use with 700 series Encoders

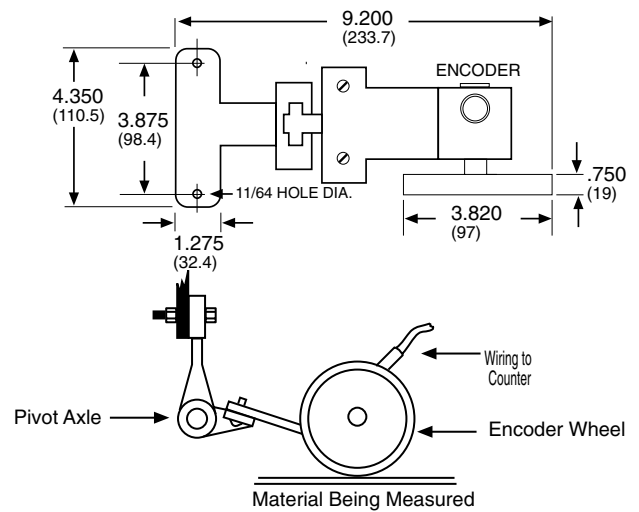
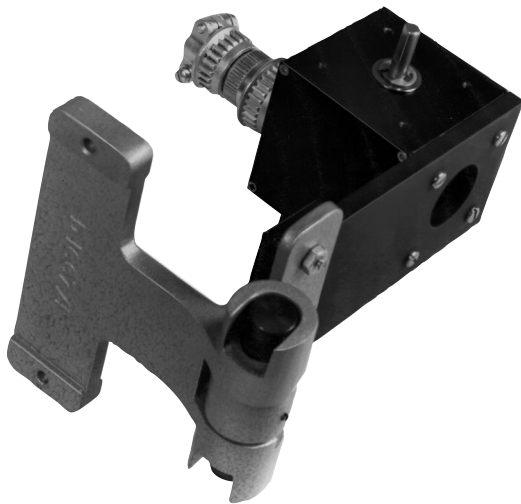

ENCODERS

ENCODER BRACKET

Surface Mount Model 7006

Use with 700 series Encoders

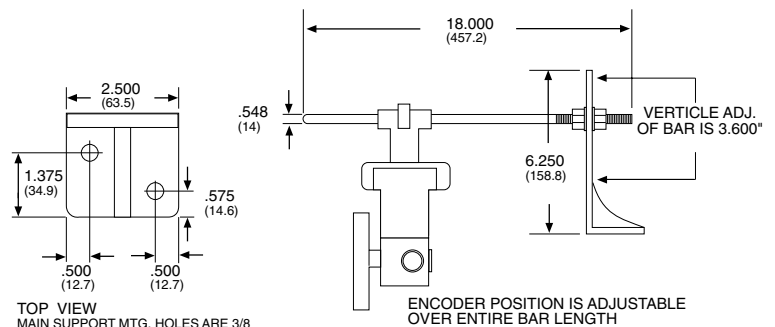
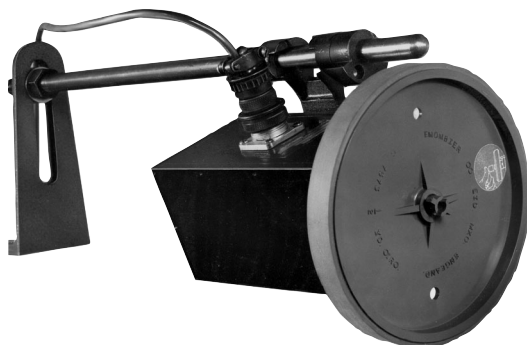

KEP Magnetic Switches

Features

- CE Approved
- Non Contact Switching
- N.O., N.C. & SPDT Industrial Reed Switches

- Momentary & Bistable Versions Available
- No Switching Power Needed (Drives KAL Series without external power)
- Long Life (Estimated 3 Billion Operations)

Switch Operations:

N.O. (third letter "S") (Closing Switch)

If a permanent magnet (a north pole [red] or a south pole [blue]) is placed near the actuating zone of the magnetic switch, the contact tongues inside the glass sealed gas protected area spring quickly to close position. When field is removed switch opens again.

N.C. (third letter "O") (Opening Switch)

A contact tongue of a switch is magnetized by an internal magnet with the south pole field. If a south pole (blue) actuating magnet is placed near the magnetic switch, both contact tongues are magnetized with the same polarity. Like poles repel each other and the magnetic switch contact opens. When field is removed switch closes again.

SPDT (third letter "U") (Change over Switch)

A change over contact has one moveable (COMM.) and two static contact tongues (N.C. and N.O.) When there is no magnetic field, contact tongue rests on the N.C. contact by means of its elastic force. When an actuating magnet is placed near it (north pole [red] or south pole [blue]) the moveable contact tongue switches. The NC contact opens and the NO contact springs to close position. When field is removed, moveable contact returns to rest position.

Bistable (fourth letter "M")

By means of an internal polarizing magnet, a contact tongue is magnetized with a south pole field in such a way that when north pole magnet (red) is placed in its proximity the magnetic switch contact changes state. The switch remains in this state until a south pole magnet (blue) is placed in its proximity.

Operating Temperature: 14° to 176°F (-10° to 80°C)

Cable

Length: 39.4" (1 M)

Color:

Jacket: Gray or Beige 0.22" (5.6mm) diameter

Inside: 19 ga.

N.O.: Brown & Blue

N.C.: Black & Blue

SPDT: Brn (comm), Blue (N.C.), Blk (N.O.)

NOTE: Some cables may have extra green/yellow wire connected to metal case.

Electronic Counting With No Outside Power:

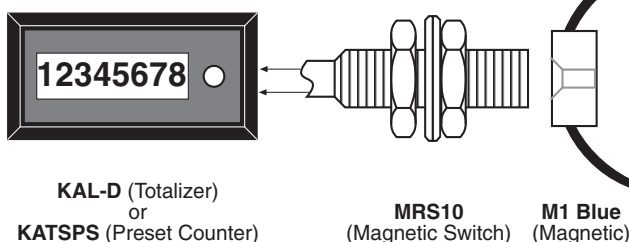

Actuating Magnets:

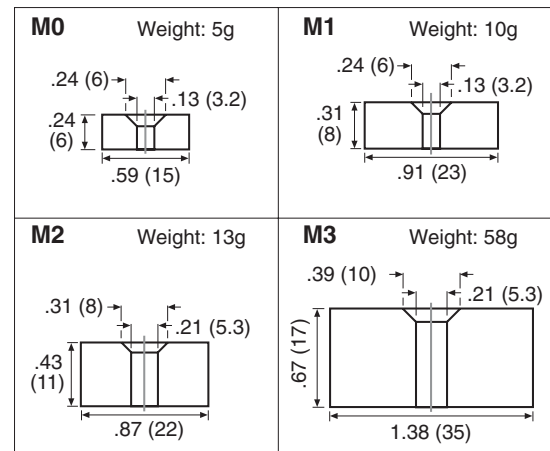

Switch & Magnet Spacing:

Mag. Switch	Magnets			
	M0	M1	M2	M3
KRS9	≈3mm	≈6mm	≈10mm	≈27mm
KRU9	≈5mm	≈9mm	≈14mm	≈30mm
KWU9	≈4mm	≈7mm	≈11mm	≈26mm
GMS9	≈3mm	≈6mm	≈10mm	≈22mm
GMU9	≈3mm	≈5mm	≈8mm	≈19mm
MRS10	≈4mm	≈7mm	≈11mm	≈28mm
MRS12	≈4mm	≈7mm	≈11mm	≈27mm
MRU12	≈3mm	≈6mm	≈10mm	≈28mm
DRS	≈5mm	≈7mm	≈11mm	≈27mm
DRU	≈3mm	≈5mm	≈9mm	≈17mm
DRSM	≈14mm	≈20mm	≈28mm	≈58mm
DRUM	≈8mm	≈15mm	≈20mm	≈45mm
FLS-AL	≈5mm	≈7mm	≈11mm	≈27mm
FLU-AL	≈3mm	≈5mm	≈9mm	≈17mm
FLSM-AL	≈14mm	≈20mm	≈28mm	≈55mm
FLUM-AL	≈8mm	≈15mm	≈20mm	≈45mm
FWU-AL	≈5mm	≈8mm	≈13mm	≈30mm
FGMS-AL	≈3mm	≈5mm	≈9mm	≈21mm

NOTE: To convert from mm to inches use the following:
mm ÷ 25.4 = inches

**Type: KRS9
KRU9
KWU9**

Technical Data:

Switching Action: Monostable

Contact Material: KRS9 & KRU9: rhodium
KWU9 - tungsten

Protection: NEMA 4X / IP65

Make/Break Capacity: KRS9 & KWU9: 60 VA max.
KRU9: 40 VA max.

Switching Voltage: 250V max.

Switching Current: KRS9: 2A max.
KRU9 & KWU9: 1A max.

Switching Frequency: KRS9 & KRU9: 300 Hz
KWU9: 100 Hz

Switching Hysteresis: KRS9 & KRU9: ≈ 5mm
KWU9: ≈ 2-3mm

Housing: Glass fiber reinforced nylon

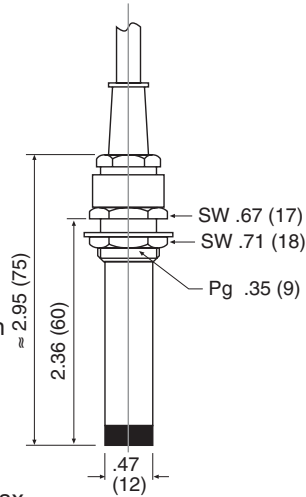

**Type: GMS9
GMU9**

Technical Data:

Switching Action: Monostable

Contact Material: rhodium

Protection: NEMA 4X / IP65

Make/Break Capacity: GMS9: 100 VA max.
GMU9: 40 VA max.

Switching Voltage: 250V max.

Switching Current: GMS9: 2A max.
GMU9: 1A max.

Switching Frequency: 300 Hz

Switching Hysteresis: GMS9: ≈ 3-4mm
GMU9: ≈ 5mm

Housing: Glass fiber reinforced nylon

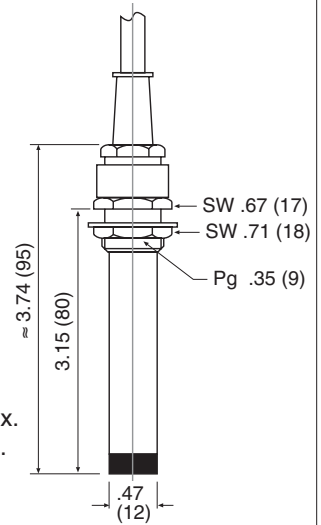

Type: MRS10

Technical Data:

Switching Action: Monostable

Contact Material: rhodium

Protection: NEMA 12 / IP54

Make/Break Capacity: 10 VA max.

Switching Voltage: 250V max.

Switching Current: 0.5A max.

Switching Frequency: 1000 Hz

Switching Hysteresis: ≈ 5mm

Housing: Brass

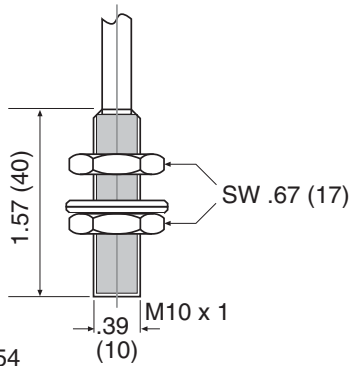

**Type: MRS12
MRU12**

Technical Data:

Switching Action: Monostable

Contact Material: rhodium

Protection: NEMA 12 / IP54

Make/Break Capacity: MRS12: 60 VA max.
MRU12: 40 VA max.

Switching Voltage: 250V max.

Switching Current: MRS12: 2A max.
MRU12: 1A max.

Switching Frequency: 300 Hz

Switching Hysteresis: ≈ 5mm

Housing: Brass

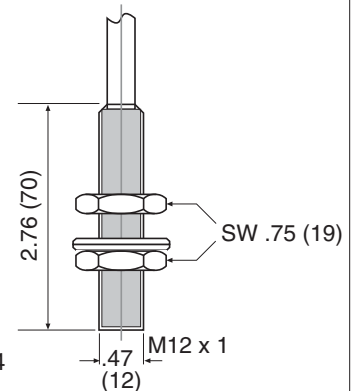

Type: DRS, DRU, DRSM, DRUM, FGMS-AL

Technical Data:

Switching Action: DRS, DRU & FGMS-AL: monostable
DRSM & DRUM: bistable

Contact Material: rhodium

Switching Frequency: 300 Hz

Switching Hysteresis: DRS & DRU: \approx 5mm
FGMS-AL: \approx 3-4mm

Protection: DRS, DRU, DRSM & DRUM: NEMA 12 / IP54
FGMS-AL: NEMA 4X / IP65

Make/Break Capacity: DRS: 60 VA max.
DRU & DRUM: 40 VA max.
DRSM & FGMS-AL: 100 VA max.

Switching Voltage: 250V max.

Switching Current: DRS, DRSM, & FGMS-AL: 2A max.
DRU & DRUM: 1A max.

Housing: DRS, DRU, DRSM & DRUM: Glass fiber reinforced nylon
FGMS-AL: Aluminum

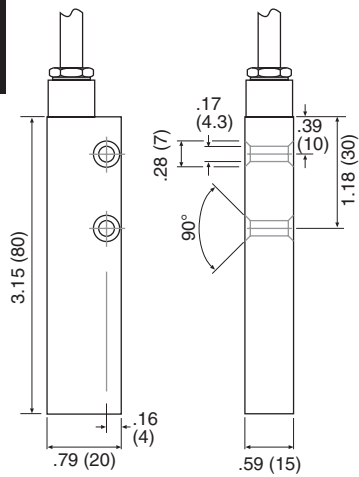

How To Order:

Actuating Magnets:

- MO (specify RED or BLUE)
- M1 (specify RED or BLUE)
- M2 (specify RED or BLUE)
- M3 (specify RED or BLUE)

NOTE: RED Magnets are North; BLUE Magnets are South

Magnetic Switches:

- KRS9
- KRU9
- KWU9
- GMS9
- GMU9
- MRS10
- MRS12
- MRU12
- DRS
- DRU
- DRSM
- DRUM
- FLS - AL
- FLU - AL
- FLSM - AL
- FLUM-AL
- FWU-AL
- FGMS-AL

Type: FLS-AL, FLU-AL, FWU-AL, FLSM-AL, FLUM-AL

Technical Data:

Switching Action: FLS-AL, FLU-AL & FWU-AL: monostable
FLSM-AL, FLUM-AL: bistable

Contact Material: FLS-AL, FLU-AL, FLSM-AL & FLUM-AL: rhodium
FWU-AL : tungsten

Switching Frequency: FLS-AL, FLU-AL, FLSM-AL & FLUM-AL: 300 Hz
FWU-AL: 100 Hz

Switching Hysteresis: FLS-AL & FLU-AL: \approx 5mm
FWU-AL: \approx 2-3mm

Protection: NEMA 4X / IP65

Make/Break Capacity: FLU-AL & FLUM-AL: 40 VA max.
FLS-AL, FWU-AL: 60 VA max.
FLSM: 100 VA max.

Switching Voltage: 250V max.

Switching Current: FLS-AL & FLSM-AL: 2A max.
FLU-AL, FLUM-AL & FWU-AL: 1A max.

Housing: Aluminum

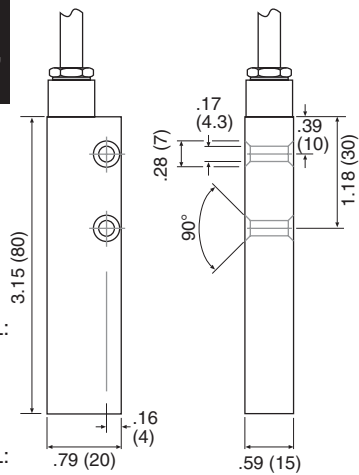

D Series

Inductive Proximity Sensors

Features:

- CE Approved
- Low Cost
- Non Contact Sensing of Any Metal
- No Magnets Needed
- Low Power Consumption
- Shock Resistant

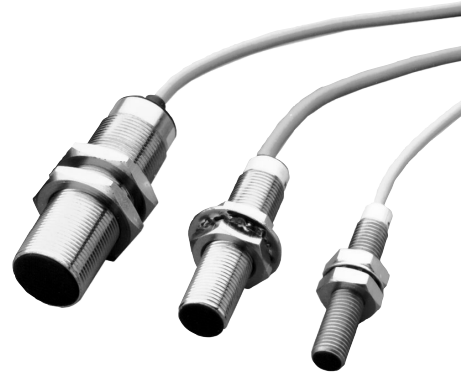

The D Series comes in three sizes, all in the easy flush mount type. Both NPN (sinking) or PNP (sourcing) types are available. They sense any conductive metal surface within range of their sensing coils. They do not require a magnetic target and are perfect for our ratemeters and counters. An LED indicator lights during activation.

	(8mm Diameter)	(12mm Diameter)	(18mm Diameter)
NPN Type (SINK)	#D08N	#D12N	#D18N
PNP Type (SOURCE)	#D08P	#D12P	#D18P
Scanning Principle	Inductive	Inductive	Inductive
Mounting Type	Flush	Flush	Flush
Switch Function	Closer (N.O.)	Closer (N.O.)	Closer (N.O.)
Switch Range; Steel	1mm ± 10% STD	2mm ± 10% STD	5mm + 10% STD
Temperature Range	-25° to +70°C	- 25° to + 70°C	-25° to +70°C
Protection Class	NEMA 4 / IP67	NEMA 4 / IP67	NEMA 4 / IP67
Housing Diameter	M8x1	M12x1	M18x1
Housing Material	Stainless Steel	Chrome Plated Brass	Chrome Plated Brass
Cable	2m, 3 x 0.14mm ²	2m, 3 x 0.14mm ²	2m, 3 x 0.14mm ²
Supply	10-30 VDC	10-30 VDC	10-30 VDC
Feed Current	~8 mA	~8 mA	~8 mA
Switch Current	1mA; Max. drop 0.7 V	1mA; Max. drop 0.7 V	1mA; Max. drop 0.7 V
Switch Current	100 mA; Max. drop 3 V	100 mA; Max. drop 3 V	100 mA; Max. drop 3 V
Frequency	2 kHz	2 kHz	1 kHz
Hysteresis, % of Range	< +15%	< +15%	< ±15%
Function Indicator	LED in Body	LED in Body	LED in Body

NPN Wiring

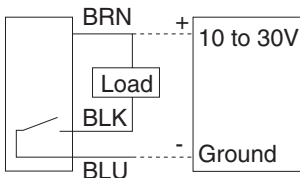

PNP Wiring

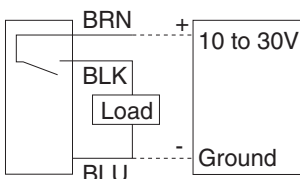

D08

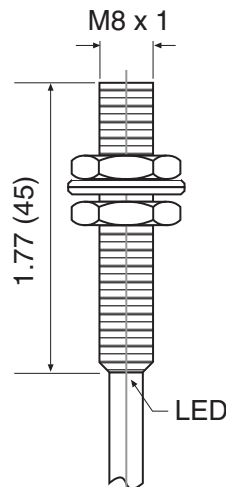

D12

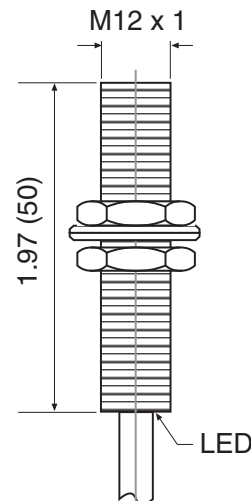

D18

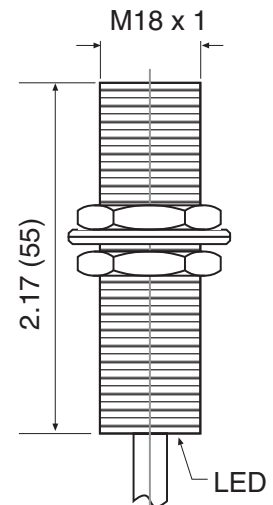

INDUCTIVE PROXIMITY SENSOR for use with KEP Counters and Ratemeters

Applications: Our D Series switches interface easily with our full line of counters and ratemeters. Use PNP switches (D_P) on all KEP units except KAL Series, which requires NPN (D_N) switches.

TYPICAL WIRING

<p>KAL-D</p> <p>CMOS/TTL COMPATIBLE CONTACT CLOSURE JUMPER OR SWITCH MOMENTARY SWITCH</p> <p>1-BLACK-COMMON 2-GREEN-RESET ENABLE 3-YELLOW-EXTERNAL RESET 4-BROWN-SLOW SPEED INPUT 5-BLUE-HIGH SPEED INPUT</p> <p>115-12 POWER SUPPLY</p> <p>BLK BLU BRN</p> <p>D12N (NPN)</p>	<p>Minicount (MC or MC2)</p> <p>RELAYS A B</p> <p>1 COMMON 2 N.O. (N.C./NPN) 3 COMMON 4 N.O. (N.C./NPN) 5 A INPUT 6 B INPUT 7 12 V OUTPUT/+ DC INPUT 8 - DC (GROUND) 9 RESET INPUT 10 NOT USED 11 AC INPUT 12 AC INPUT</p> <p>POWER COUNT GROUND</p> <p>D12P</p>														
<p>Minirate (MR2 or MR)</p> <p>1 RATE INPUT 2 12 VOLT OUT SIGNAL 3 GROUND 4 BRN 5 BLU 6 BLK 7 A</p> <p>Just sense the keyway - No gears Required!</p> <p>D12P (PNP)</p>	<p>KALtrol (KAT1)</p> <p>1 AC Main 2 AC Main Neutral 3 + 12 DC / 8-30 VDC in 4 Relay Common 5 Relay N.C. 6 Relay N.O. 7 AC/DC Reset 8 AC/DC Count 9 AC/DC Common 10 Keypad Disable 11 *High Speed Count Input 12 0V / DC Ground</p> <p>*Select PNP (SW1 OFF)</p> <p>D12P</p>														
<p>KAL-DR/T</p> <p>1-BLACK-COMMON 2-GREEN-SLOW SPEED INPUT 3-YELLOW-PERIODGATED MODE SELECT 4-BROWN-HIGH SPEED INPUT</p> <p>115-12 POWER</p> <p>BLK BLU</p> <p>D12N (NPN)</p>	<p>How To Order:</p> <table border="1"> <thead> <tr> <th>TYPE</th> <th>SIZE</th> </tr> </thead> <tbody> <tr> <td>NPN Type</td> <td>D08N</td> </tr> <tr> <td>(sink)</td> <td>D12N</td> </tr> <tr> <td></td> <td>D18N</td> </tr> <tr> <td>PNP Type</td> <td>D08P</td> </tr> <tr> <td>(source)</td> <td>D12P</td> </tr> <tr> <td></td> <td>D18P</td> </tr> </tbody> </table>	TYPE	SIZE	NPN Type	D08N	(sink)	D12N		D18N	PNP Type	D08P	(source)	D12P		D18P
TYPE	SIZE														
NPN Type	D08N														
(sink)	D12N														
	D18N														
PNP Type	D08P														
(source)	D12P														
	D18P														

PD Series

Photoelectric Sensors

Features:

- Low Cost
- Non Contact Sensing
- Various Sensing Types
- Low Power Consumption
- Shock Resistant

Description:

The PD Series photoelectric sensors offer superior optical performance in a miniature 18 mm package. Designed specifically for a wide variety of applications, including food processing, packaging, and materials handling. Their miniature size makes it easy to design into any system.

The PD Series provides flawless operation in the harshest environments. Rated NEMA 4, 6, and 13, the PD Series keeps working in wet and high-pressure washdown situations even under water. The PD Series is highly immune to extreme shock and vibration, and passes the NEMA ICS 1-109 showering arc test. Even walkie-talkies won't interfere with it's performance.

PD Series sensors are available in 10-30 VDC thru-beam reflex, and proximity configurations. Infrared, visible-beam, and polarized models are available, as is a complete line of fiber optic cables. Easy alignment is provided by a variable intensity indicator (patents pending) on all models, and by an additional forward-looking alignment indicator on thru-beam models.

The unique "round and square" profile makes installation easy. It can be screwed into standard 18 mm threaded brackets. Bulkhead mounts are mounted flush against any surface. Electrical connections are made via an all purpose cable.

New From KEP—Sensi Prox...

The PD Series introduces a photoelectric breakthrough: SENSI-PROX. Unlike other proximity sensors whose signal strengths drop off gradually, KEP's SENSI PROX proximity sensor has an extremely sharp cut-off. Because of this, SENSI PROX sensors provide superior background suppression and absolute detection at precise distances.

Accessories:

Retroreflectors and mounting brackets are available to complete the installation of your PD Series sensor.



Specifications:

ELECTRICAL (all models)

Input voltage: 10-30 VDC (above 55°C derate to 24 VDC at 70°C)

Power dissipation: 1W max

Response time:

Dark-to-light: 1 mS max

Light-to-dark: 1 mS max

Sensitivity adjustment: 20:1 ratio

Power on delay: <300 mS

Output type and rating:

Source and sink transistors:

Sourcing: 100 mA max

Sinking: 250 mA max (above 55°C, derate sinking output to 120 mA max at 70°C) Off-state voltage: 30 VDC max

Off-state leakage: 10 μ A max

Light/Dark Operation: When the Lt/Dk control is in the Lt position (fully clockwise) the outputs turn on when the beam is complete. When in the Dk position, the outputs turn on when the beam is broken.

Alignment Indicator: LED intensity varies with signal strength to aid alignment. LED status:

OFF: power is off

DIM: power is on, but beam is broken

BRIGHT: power is on, and beam is complete (unbroken). Intensity varies with signal strength.

Mechanical/Environmental:

Operating temperature: -20°C to +70°C (-4°F to +158°F)

Storage temperature: -20°C to +70°C (-4°F to +158°F)

Humidity: 95% RH, noncondensing

Case material: Rigid Polyurethane

Lens material: Polycarbonate

Vibration: 30g or 0.06 in displacement, whichever is less, from 50 Hz to 2 kHz

Shock: 100g for 3 ms 1/2 sine wave pulse

Ratings: NEMA 4, 6, 13

Mounting: Side or 18 mm thru-hole (see dimensions).

Cable Length: 6 feet

Side mounting: Use #4 screws to attach the sensor to a wall or mounting bracket. Thru-hole mounting: The sensor can be mounted through an 18 mm (0.71 in) diameter hole using nuts included with the sensor.

NOTE: All sensors UL and CSA approved.

WIDE-ANGLE THRU-BEAM
PDS 25 — 10-30 VDC source
PDD 25 — 10-30 VDC detector
Maximum range: 25 ft.
Effective beam: 0.25 in diameter
Field of view: 40 in. at 100 in.
Sunlight immunity: 10,000 footcandles

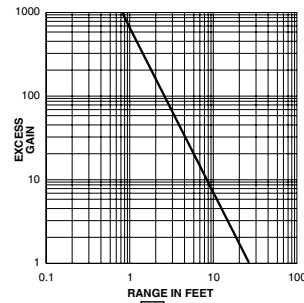

VISIBLE-BEAM SENSI PROX (Diffused)
PROXIMITY
PDP02 — 10-30 VDC

This sensor has a precise gain cut-off (from an excess gain of 20 to 1 in 150-thousandths of an inch) which makes it ideal for applications in which background suppression is necessary. This sensor also emits a visible beam of light for easy alignment.
Maximum range: 2.25 in.
Optimum range: 0 to 2.25 in.
Detection spot diameter: 0.1 in. at 2 in.
Sunlight immunity: 10,000 footcandles

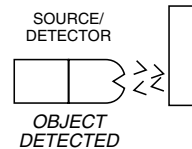
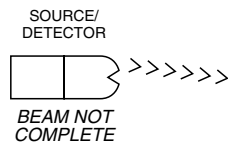
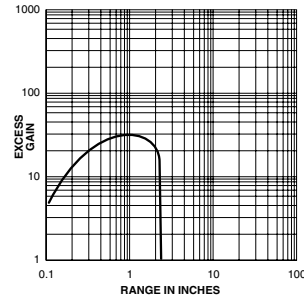

SHORT-RANGE PROXIMITY (Diffused)
PDP08 — 10-30 VDC
Maximum range: 8.0 in.
Optimum range: 0 to 4.0 in.
Field of view: 2 in. at 5 in.
Sunlight immunity: 10,000 footcandles

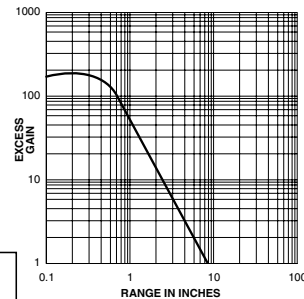
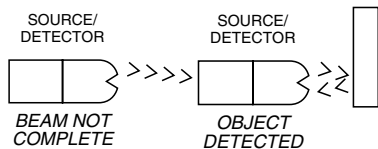

VISIBLE-BEAM REFLEX
PDR25 Series — 10-30 VDC
This sensor emits a visible beam of light for easy alignment.
Maximum range: 25 ft.
Optimum range: 0 to 15 ft.
Field of view: 2 in. at 100 in.
Sunlight immunity: 10,000 footcandles

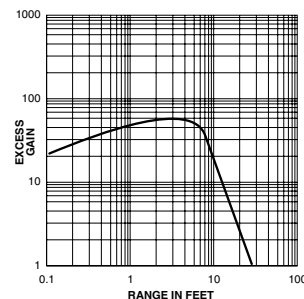
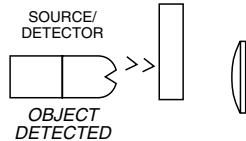
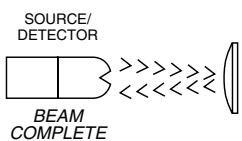

POLARIZED VISIBLE-BEAM REFLEX
PDR15 Series — 10-30 VDC

The polarized reflex sensor responds only to light reflected from a hard surface retroreflector as T3.0 or T.5. It does not respond to most reflective tapes nor shiny objects. This feature is important in applications where shiny objects such as cans or bottles are to be detected. This sensor also emits a visible beam of light for easy alignment.

Maximum range: 15 ft.
Optimum range: 0 to 10 ft.
Field of view: 1 in. at 50 in.
Sunlight immunity: 10,000 footcandles

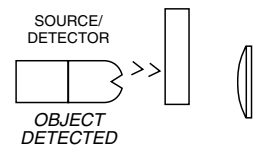
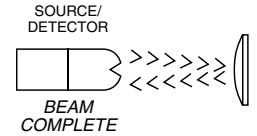
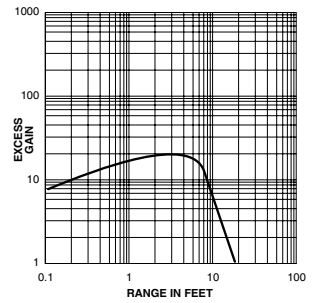

FIBER OPTIC SENSOR
PDF Series — 10-30 VDC

Special purpose sensor for use with the plastic fiber optic cable family. Fiber optic cables plug into sockets on the front of the sensor. Sensor operates in thru-beam or proximity mode depending on the fiber optic cable selected.

Maximum range:
0.65 in. for 0.04 in. fiber optic cables in proximity mode.
6 in. for 0.04 in. fiber optic cables in thru-beam mode.
0.3 in. for 0.02 in. fiber optic cables in proximity mode.
1.5 in. for 0.02 in. fiber optic cables in thru-beam mode.
Field of view: Depends on fiber optic cable selected
Sunlight immunity: 10,000 footcandles

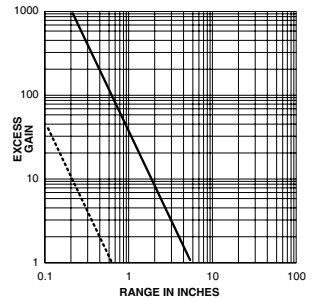

----- Prox Performance
— Thru-Beam Performance

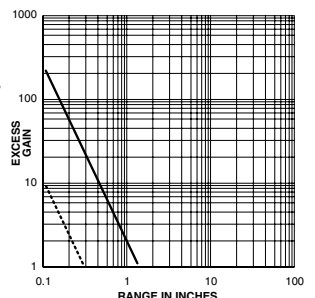

----- Prox Performance
— Thru-Beam Performance

HOW TO PICK THE RIGHT SENSOR

1) Most applications can be satisfied with a reflex unit, one that sends out a light signal to bounce off a reflector back to the source. This unit is ideal for sensing ranges from 1" to 15 ft. Use P/N PDR Series and order a PDA T.5 or PDA T3.0 reflector.

BOX COUNTING

MODEL #	DESCRIPTION
PDR25	Reflex Sensor
PDA3.0	Retroreflector

A single reflex control detects boxes anywhere on a four foot wide conveyor. Interfacing the control with a KEP counter provides totals.

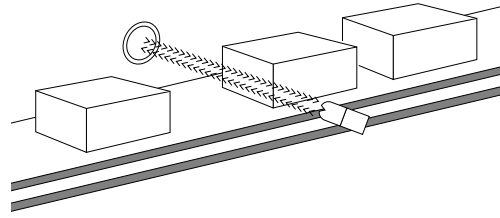

2) If you have shiny objects to be detected like metal cans or covered in shiny shrink wrap that might accidentally act as a refl and trip the sensor, use the Polarized reflex unit. It works best to 10 feet. Use a PDR15 and a hard surface target reflector.

BATCH COUNTING AND DIVERTING

MODEL#	DESCRIPTION
PDR15	Polarized Reflex Sensor
PDAT3.0	Retroreflector

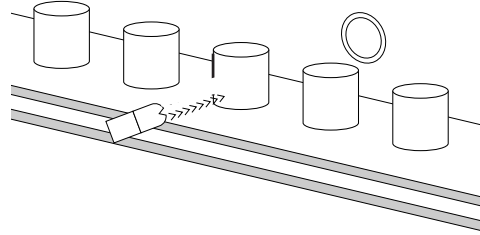

3) If you can look directly at the object to be sensed and there are no objects to false trigger the unit, you only need to look 4 inches or less to see the object. Use PDP08.

4) If you want to look out only 2 inches and ignore objects very close to that range, we have a special product with total background suppression. Use PDP02.

FILTER PAPER LENGTH CONTROL

MODEL #	DESCRIPTION
PDP02	Sensi Prox

A fixed-focus proximity control with the standard output interfaces with a KEP Counter to measure a specific length of corrugated automotive filter

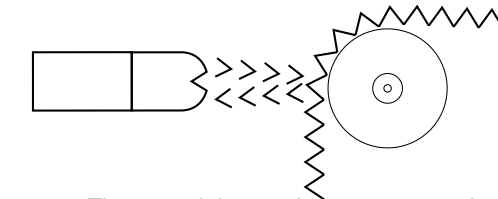

paper. The control detects the presence or absence of a corrugation. When a predetermined number of corrugations has been detected, the Keptrol or Intellect counter closes a relay, which directs a shear to cut the paper.

5) If you have to look very far or if you are looking thru a very smokey or dirty area, thru beam sensors are the most powerful type of photo-electrics because the light only travels one way. It leaves the source and is received at the detector. Of course, you will have to buy and wire two separate units for a thru beam application. Use PDS25 and PDD 25.

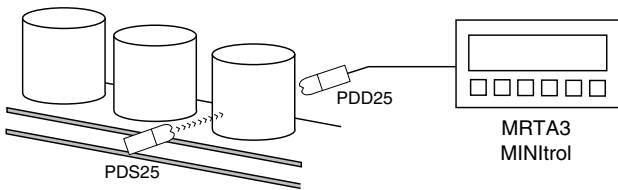

PDABA BRACKET

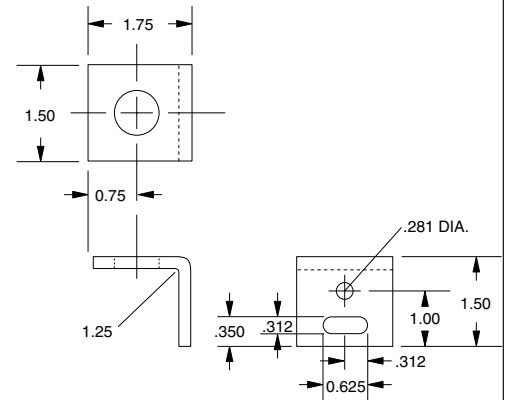

PDABS SWIVEL BRACKET

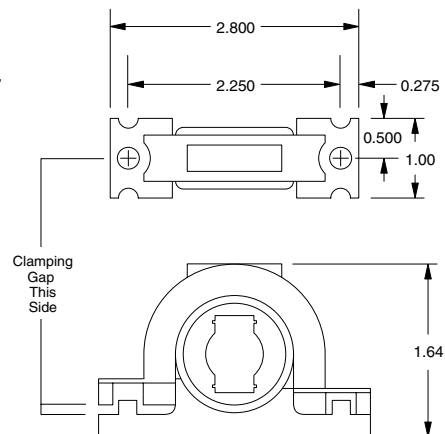

6) Now if you really have some special requirements — small space, high temperature, intrinsic safety needs or very small object detection, use our Fiber Optic Unit. Use P/N PDF00 with appropriate fibers ordered separately.

WIRING DIAGRAMS:

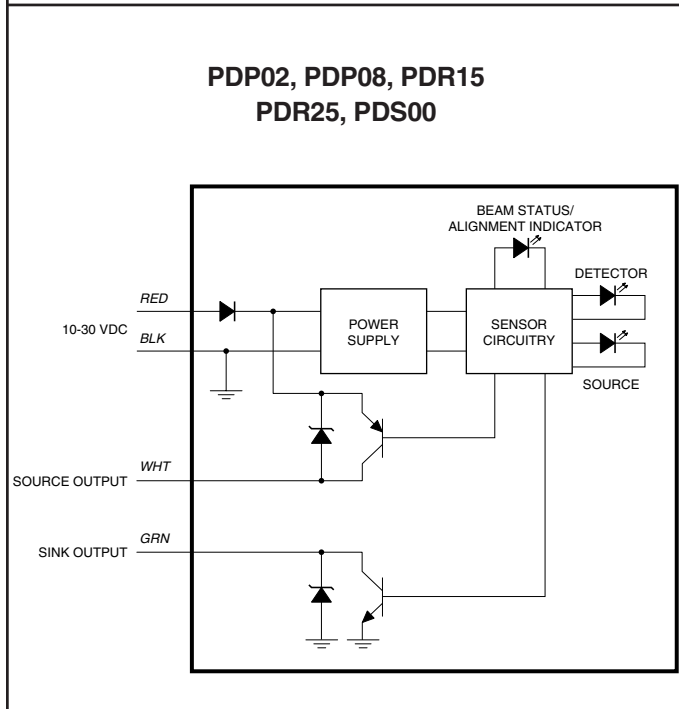
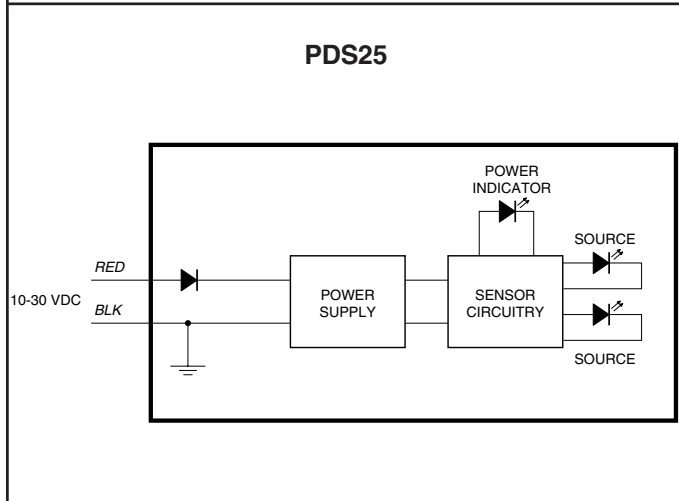
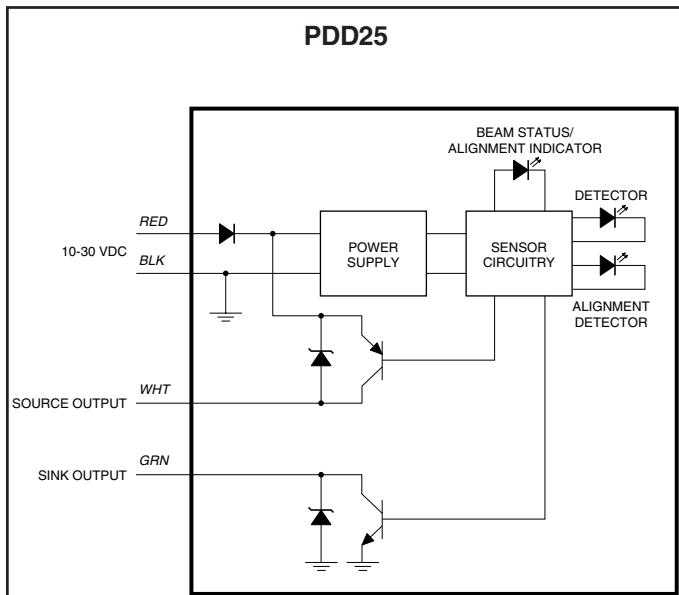

DIMENSIONAL DIAGRAMS:

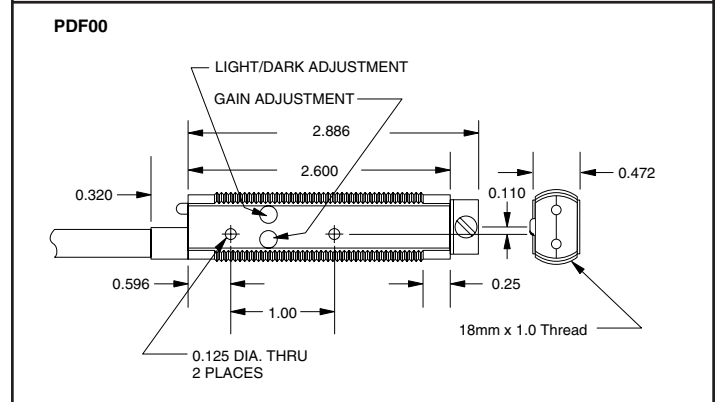
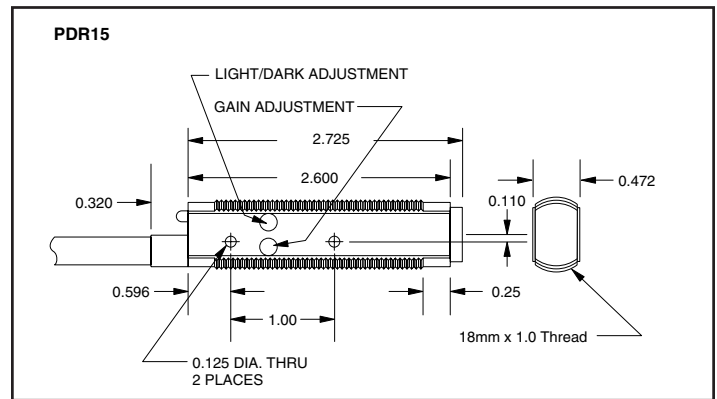

How To Order:

EXAMPLE: PD R 25

Series Photo Detector

Style _____

S = Source	25
D = Detector	25
P = Prox (Sensi Prox)	02
PS = Prox (Short Range)	08
R = Reflex (Visible)	25
RP = Reflex (Polarized)	15
F = Fiber Optic	00

Maximum Range _____

0X = (in inches)
XX = (in feet)

ACCESSORIES:

EXAMPLE: PDA T3.0

Series Photo Detector Accessories

Type _____

F1 = Fiber Bifurcated Reflex	78" long - cut to desired length
F2 = Fiber Thru-beam (set of 2)	78" long - cut to desired length
T3.0 = Target - round reflector 3" dia.	(2 per package)
T.5 = Target - round reflector 0.5" dia.	(2 per package)
TX X = Target Tape - 2" (specify length _ _)	
BS = Bracket - swival	
BA = Bracket - 90° angle	(2 per package)

SENSORS

Industrial Instruments REPLACEMENT PRODUCTS

The following is a list of replacement products. The products listed below are either obsolete, sold for replacement only or replaced by a newer KEP product. Please call the factory for pricing or technical information.

MTHVS
MLTHVS
HK15 (OBSOLETE; Replaced by HK17)
T610, TR510, T603 (OBSOLETE; Replaced by H57)
QT 15 (OBSOLETE; Replaced by HK17)
KP7 (OBSOLETE; Replaced by 904K)
M16
M18
CHC
CHH
CHR
AW16
W16
ED15
MVS13
MVS16

EVS15
ETSVS
ETMVS
ETHVS
E14
E16
ET SERIES
LT SERIES
ER SERIES
INT 61 (Refer to MC2 for replacement)
INT 66
INT 63 (Refer to MR2 for replacement)
INT 64 (Refer to INT69R for replacement)
INT 65 (Refer to INT69T for replacement)
L SERIES
KP6 COUNTER (OBSOLETE; Replaced by CTF5)

8000 Series

Electronic Counter



Visit
www.kep.com
for datasheet

8200-8400 Series

Electronic Timer



Visit
www.kep.com
for datasheet

OMNI Series

Preset Counter



Visit
www.kep.com
for datasheet

OMNI Series

Preset Timer



Visit
www.kep.com
for datasheet

SCPS Series

Preset Counter



Visit
www.kep.com
for datasheet

SCPT Series

Preset Timer



Visit
www.kep.com
for datasheet

SENSORS

Industrial Instruments ACCESSORIES

Spare Parts

ORDER NO.	DESCRIPTION
Model 36120	Flex Cover
KEPTROLBEZEL	Front panel bezel for KEPTrol
KP8CASE	Case for KEPTrol
TROLCLAMP	Mounting Kit (4 clamps & gasket)
*BATCHMAINRT3L	KP8, KRT, BT2 Mainboard
KEPTROLDISP	KP8, KRT, BT2, FLO8 Display Board

*PROM sold separately (see below)

MINITROL Input Chips

ORDER NO.	DESCRIPTION
EPLDMRTIN3	High Impedance input chip for Minitrol
EPLDMRTIN5	Up/down control input chip for Minitrol
EPLDMRTIN9	Quadrature input chip for Minitrol

KEPTrol Program Chips

ORDER NO.	DESCRIPTION
PROMKP8V1.7	PROM for KEPTrol
PROMRSV1.0	PROM for Trol RS422 & RS232

INT69 & MINITROL ACCESSORIES

ORDER NO.	DESCRIPTION
34235	Non Keyboard Front Panel
34237	Keyboard Front Panel

N7 HOUSING

Explosion Proof Housing for N7 Hazardous Areas

Use With the Following KEP Models:

MK Series, B Series, BVA Series, MVS Series, KAL-D Series, 520 Series and KAT-SP Series

Description:

Most KEP series totalizers and Elapsed Timers (less than 3.1" deep) can be factory installed in this explosion proof housing. An optional approved local pushbutton located on the housing provides reset (for units with electric reset) without violation of safety requirements. Electrical reset can also be located at a remote station.

When safe conditions exist, the screw-on cover with its glass window may be removed for field wiring, maintenance or to change preset values.

The housing may be drilled and tapped to customers requirements, up to 2" NPT. Unless otherwise specified, housing is drilled and tapped for 1/2" NPT as illustrated and 3/4" NPSM if reset button is ordered.

Specifications:

Rating: Class I, Groups C & D
Class II, Groups E, F, G
Class III

Max. Depth Behind Panel: 3.1"

Max. High Above Panel: 0.625"

Weight of Housing: 6 lb. Max.

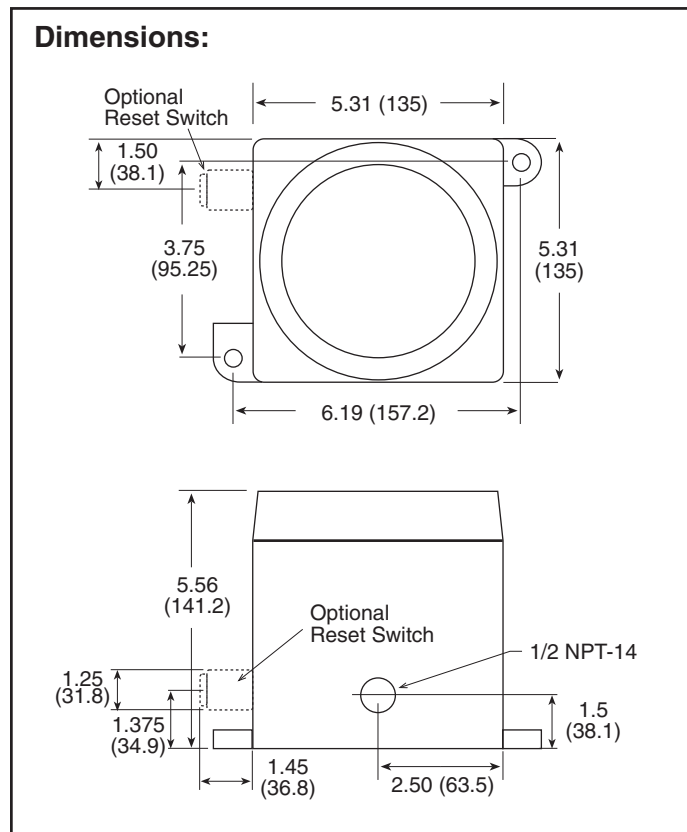
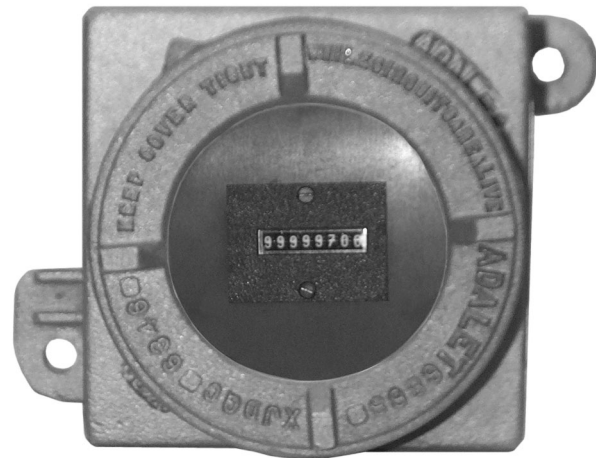

Ordering Examples:

Model Housing	Local Reset Option (R) if used	Counter Catalog Number (Use #1 or Clip Mount)
N7	R	529K.2
N7	R	MK18.10 24VDC 25CPS
N7	R	KAT-SP

N3, N4, N12 HOUSING

NEMA 3,4 or 12 Housing for Counters/Timers

Features

- NEMA 12 - Dust and Oil Tight
- NEMA 3 - Waterproof for Outdoors
- NEMA 4 - Waterproof for Indoors
- 14-Gauge Welded Seam Construction
- For Use with MK16/18 Counters and M16/18 Timers

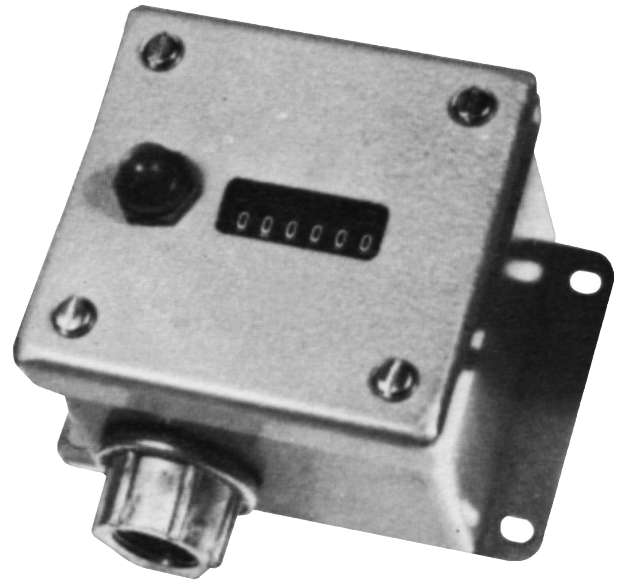

Description

The MK series counters and M series timers may be supplied in the NEMA 3, 4 or 12 enclosure. The removable covers have wide neoprene gaskets and are held by captivated screws which thread into sealed wells in the enclosure body. 14-gauge welded seam construction is used for throughout. Finish is baked blue hammertone over phosphorized surface. The lexan window will not shatter or discolor. The enclosure is available for MK16, MK18 series counters and M16, M18 series timers.

Type of Counters:

- MK16.10** - 6 digit, no reset
- MK18.10** - 8 digit, no reset
- MK16.12** - 6 digit, push button reset
- MK16.12KS** - 6 digit, key reset

Type of Timers:

- Mxx16.10** - 6 digit, no reset
- Mxx18.10** - 8 digit, no reset
- Mxx16.12** - 6 digit, push button reset
- Mxx16.12KS** - 6 digit, key reset

How To Order:

(add suffix to part number of counter/timer)

- N-12** - NEMA 12, industrial dust and oil tight
- N-3** - NEMA 3, dust tight, rain tight and sleet & ice resistant - for outdoor use
- N-4** - NEMA 4, water dust tight - for indoor use

Dimensions:

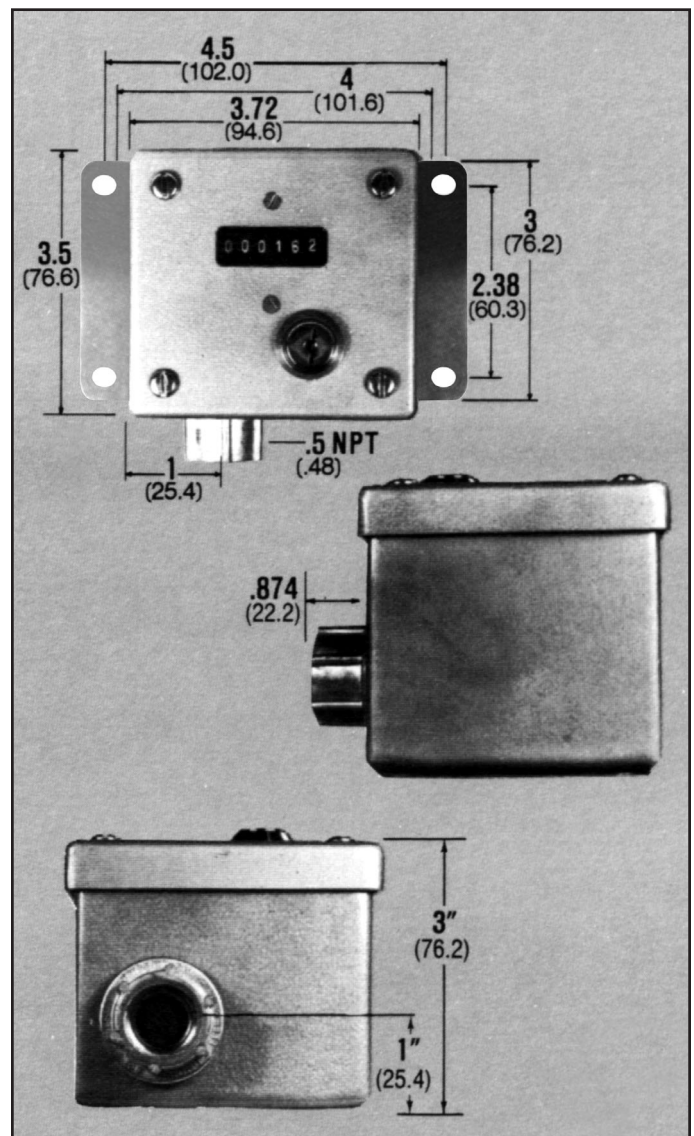

E200

Outdoor Enclosures For Units in 1/32 DIN Cases

Features

- Low Cost
- Compatible with all Standard 1/32 DIN Products
- NEMA 3R (raintight) Enclosure
- Quick-Release Latches with Security Lock Provision
- Light Weight

E200 Plastic Outdoor Enclosure

The E200 is a Plastic NEMA 3R raintight enclosure with hinged door and latch. It offers provisions for mounting up to four of ANY KEP 1/32 DIN sized units. The E200 also offers five combination 1/2"-3/4" knockouts: In bottom, sides and back for easy wiring and conduit connections. Exterior Size: 6.5" x 10" x 3.75" deep. Interior Size: 4.75" x 7.75" x 3" deep. Dark grey plastic finish.



Compatible with all Standard 1/32 DIN Products Including:

- KAL D Series
- KAL D Time Series
- 130K - 136K Series
- 520K - 530K Series

Dimensions:

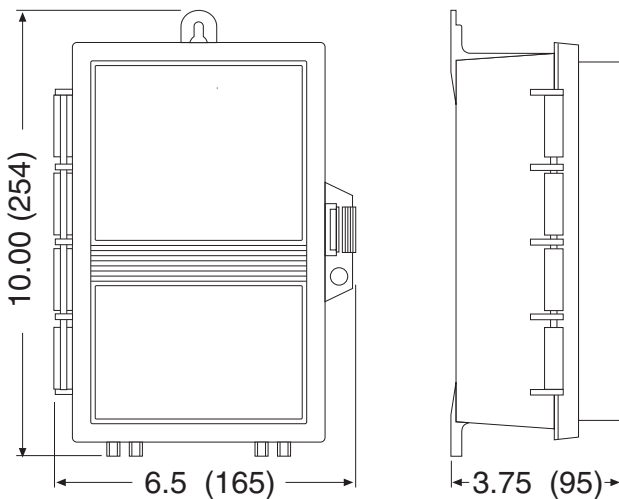

Ordering Information

Part Number	Description
E200-0	E200 Enclosure with no cutout
E200-1	E200 Enclosure with 1 cutout
E200-2	E200 Enclosure with 2 cutouts
E200-3	E200 Enclosure with 3 cutouts
E200-4	E200 Enclosure with 4 cutouts

NEMAtrol

NEMA 4X/IP65 Enclosures For 'trol & 1/8 DIN Cases

Features

- Compatible with all Standard Size "trol", SUPERtrol & 1/8 DIN Products
- Meets NEMA 4X/IP65 Specs.
- Quick-Release Latches
- Light Weight

Application:

Ideal for use in most petro-chemical plants, sewage plants, food processing areas, packing plants, electro-plating plants, etc.

Construction:

- Molded fiberglass reinforced polyester material has excellent chemical resistance and outstanding physical properties.
- Fiberglass material is easily punched, drilled, filed or sawed.
- Oil-resistant gasket attached with oil-resistant adhesive.
- The enclosures have corrosion-resistant fiberglass hinges and spring-loaded fiberglass latches attached with monel screws.



Ordering Information

Part Number

NEMAtrol4X (NEMA 4X enclosure for all standard 'trol units 7.365" x 2.495" cutout)
 NEMAtrol 4x0 (no cutout)
 NEMAtrol 4x1 (1 cutout)
 NEMAtrol 4x2 (2 cutouts)

NEMAST4X (NEMA 4X enclosure for SUPERtrol series)
 NEMAST 4x1 (1- 5.43" x 2.68" cutout for SUPERtrol series)
 NEMAST 4x2 (2- 5.43" x 2.68" cutout for SUPERtrol series)

NEMA-1/8DIN (NEMA 4X enclosure for all 1/8 DIN size units)
 NEMA-1/8DIN 4x0 (no cutout)
 NEMA-1/8DIN 4x1 (1 cutout)
 NEMA-1/8DIN 4x2 (2 cutouts)

Physical Properties	Enclosure Value	ASTM Method
Flexural Strength	17,000 PSI	D-790
Heat Distortion	400° F	D-648
Water Absorption (24hrs.)	.5%	D-570
Tensile Strength	6,500 PSI	D-651
Specific Gravity	1.8	D-792
Flammability	94-5V	UL94
Dielectric Strength	400 V.P.M	D-149
Arc Resistance	180 Sec.	D-495

Dimensions:

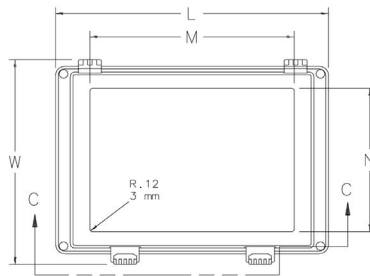

Top View with Cover

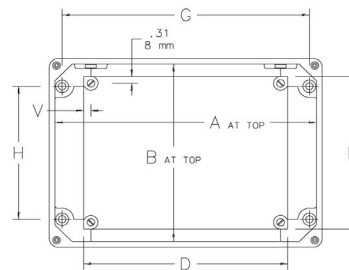

Top View with Cover Removed

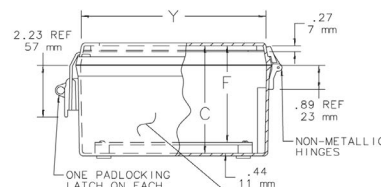
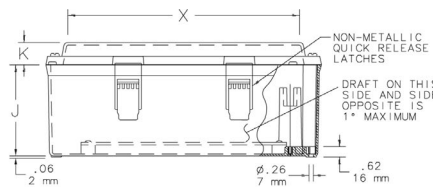

NOTES: 1. Panel screws have # 10-32 threads.
 2. Hinged cover opens 200° maximum.

Part Number	A x B x C	D x E	G x H	L x W	F	J	K	V	X	Y
NEMA-1/8DIN	7.50 x 6.00 x 5.28 (191 x 152 x 134)	4.88 x 4.88 (124 x 124)	6.75 x 4.00 (171 x 102)	8.00 x 7.39 (203 x 188)	4.75 (121)	4.38 (111)	1.00 (25)	0.31 (8)	6.22 (158)	5.59 (142)
NEMAtrol4X	11.50 x 8.00 x 6.78	8.75 x 6.88	10.75 x 6.00	12.00 x 9.39	6.25	5.13	1.75	0.25	9.97	7.34
NEMAST4X	(292 x 203 x 172)	(222 x 175)	(273 x 152)	(305 x 239)	(159)	(130)	(44)	(6)	(253)	(186)

ACCESSORIES & REPLACEMENT

Installation Of Electronic Instruments In Industrial Environments

1) Supply line

An MOV (metal oxide varistor) placed across the supply lines at the unit often clips the high voltage spikes sufficiently to prevent malfunction. A line filter offers added protection (See Figure A). For areas where there are large power surges caused by switching on and off large motors, solenoids, welders, etc. or by electronic switching of large variable speed drives, it may be necessary to install lightning arrestors or isolating power supplies to run the electronic equipment.

2) Relay Contact

Arc suppression is needed across inductive loads such as solenoids, motors, or even other small relay coils driven by relay contacts. When the contact opens, large electrical spikes are generated. These noise spike, in addition to degrading the relay contact, can radiate off the output lines and into sensitive areas of the equipment. The best way to alleviate this situation is to suppress the spike at the coil itself.

For DC powered coils a simple diode as IN4000 Series placed across the DC coil is usually very effective (cathode-banded side of diode connected at more positive side of coil and anode connected to other side of coil. See Figure B.)

For AC powered coils, an MOV placed across the coil clamps the voltage and usually eliminates the malfunction. Another method to suppress the noise is to place a capacitor across the coil. A .05 to .1 μF ceramic capacitor rated at 3 times the operating voltage will slow down the rise of the spike thus lessening harmful effects. At times a combination of the MOV and capacitor is needed to clamp the voltage and slow down the rise.

For AC or DC powered coils, a Resistor-Capacitor Surge Suppressor placed across the coil will extend the life of relay contacts and will reduce the possibility of electronic instruments being adversely affected by electrical noise. The Surge suppressor should be connected directly on the coil terminals of the load device being suppressed. If this is not possible, connect the suppressor at the terminal strip closest to the load being suppressed. The suppressor should be connected in parallel with the inductive load.

3) RFI Noise Through The Air

If electrical noise cannot be suppressed, it is recommended that any electronic equipment be mounted away from the relay coils, solenoids or other noise sources to avoid RFI or EMI caused malfunction. Often it is sufficient to separate the two by 6" to 12" but metal shielding or separate cases may be necessary where there are strong fields from relay coils, solenoids, welding equipment or large motors.

4) Signal Input Lines

Input signal lines should be run separately from power lines or lines that may have large surges that may couple into the signal lines. They should not be run in the same trough nor bundle as power lines. It is a good practice to run these low current signal lines through shielded cable with the shield tied to DC ground at the source. Tying the shield to earth ground is recommended only if there is still noise interference after the unit is installed. As often as not, the shield connected to ground causes as many problems as it solves. If the shield is tied to earth ground it should be connected at one place, ideally close to the DC ground

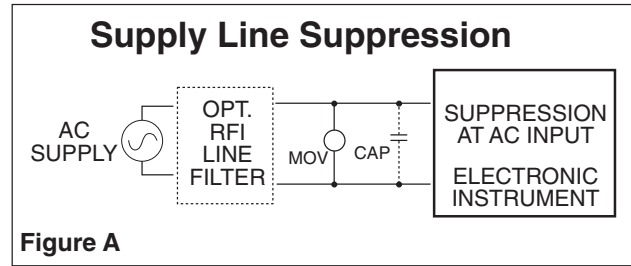

Figure A

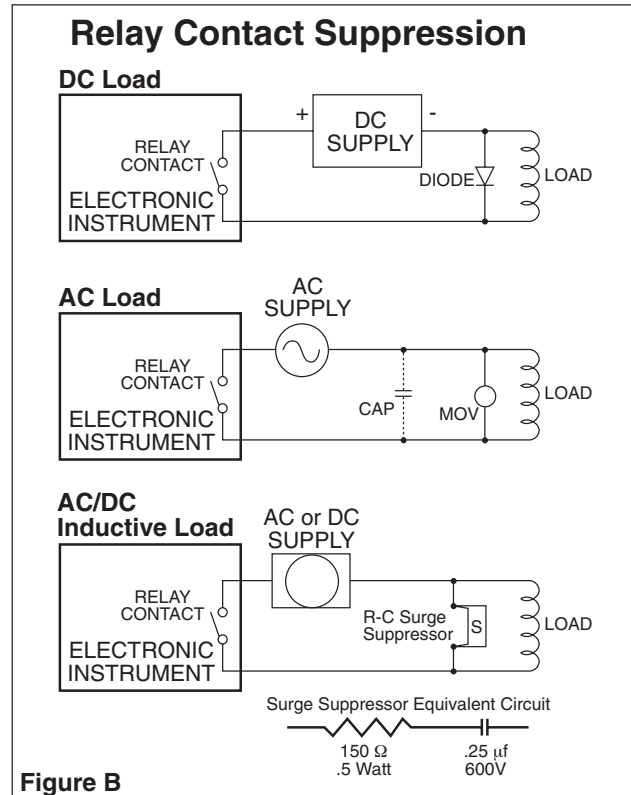

Figure B

Optional Arc Suppressors

Description	KEP#	Industrial Equivalent
Diode IN4005	38012	IN4000 Series
MOV 115 VAC	30090	GE#V130LA10
MOV 230 VAC	30124	GE#V250LA10
.05 μF @ 600V Cap	32013	0.1 to 0.05 μF @ 60V Cap.
RFI Line Filter	N/A	GE#1B1, Corcom#1R1
Quencharc	32145	ITW 104150

KEP Contact List

<u>CONTACT</u>	<u>TITLE</u>	<u>PHONE</u>	<u>E-MAIL ADDRESS</u>
Administration			
Corky Ellis	CEO	629	corky@kep.com
Peter Sabat	President	328	peter@kep.com
Product Managers			
Richard Gruskos	Flow Products	318	richard@kep.com
Ron Dawson	PLC Peripheral & Industrial PC	332	ron@kep.com
Richard Woods	Industrial Instruments	315	richw@kep.com
Sales Managers			
Peter Sabat	President, Sales & Marketing, International Sales	328	peter@kep.com
Paul Bengs	Vice President, Sales & Marketing West Regional Sales	949 496-7333	paul@kep.com
Corky Ellis	International Sales	629	corky@kep.com
Tony Zuccarelli	Eastern Regional Sales Manager	329	tony@kep.com
Patrick Fitzgerald	Canada/Mexico Sales Manager	369	patrick@kep.com
Chris Maslak	Central Regional Sales Manager	327	chrism@kep.com
Jesse Paz	SouthW. Regional Sales Manager	909 582-0018	jesse@kep.com
Customer Support			
Patty Bickauskus	Customer Service Manager	359	pattyb@kep.com
Dolores Milko	Customer Service	360	doloresm@kep.com
Rusty Barry	Order Entry / Expediting	364	rustyb@kep.com
Barbara Meisler	Administrative Assistant / Literature	314	barbara@kep.com
Chuck Hull	Purchasing Manager/Shipping	317	chuck@kep.com
Technical Support			
Richard Gruskos	Sr. Applications Engineer Flow	318	richard@kep.com
Brian Walter	Sr. Applications Engineer PLC	390	brian@kep.com
Louis Fligor	Applications Engineer	321	louis@kep.com
Richard Woods	Applications Engineer	315	richw@kep.com
Christian J. Maslak	Applications Engineer	327	chrism@kep.com
Keith Sabat	PC Applications Engineer	301	ksabat@kep.com
Glenn McHugh	Technical Support	381	glenn@kep.com
Pat Hoolahan	WebMaster	335	webmaster@kep.com
Quality			
Frank Colucci	Quality Manager	323	frankc@kep.com
Kevin McWeeney	Product Technician	309	kevin@kep.com
Greg Lemon	PLC Interfaces Technician	379	greg@kep.com
Diana Corbett	II Technician	348	diana@kep.com
Jessica Strasko	Flow Product Repair Tech.	310	jessica@kep.com
Order Processing			
Order Desk	Fax Line #:	732 935-0421	



Kessler-Ellis Products, Co.

**10 Industrial Way East
Eatontown, NJ 07724**

**Phone: (732) 935-1320
(800) 631-2165
Fax: (732) 935-9344**

<http://www.kep.com>