

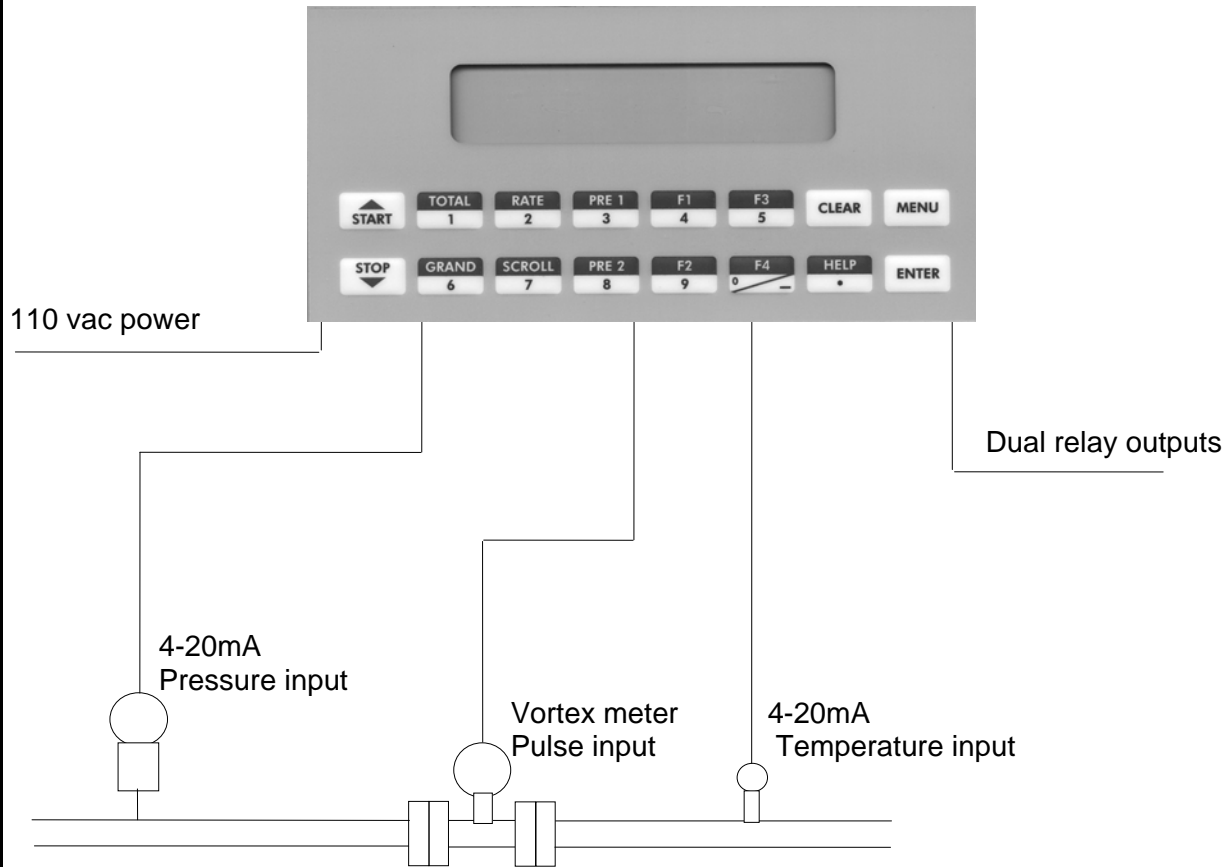

Kessler-Ellis Application Note F007

ES-747 Flow Computer Monitoring Argon Flow and Displaying Compensated Volumetric Flow



The ES-747 utilizes the pressure and temperature signals, as well as user input data, to compute the density of the flowing Argon. The ES-747 then performs a calculation that is referenced to standard conditions. The result of the calculation is displayed in SCFM or NM^3 per hour and totalized in SCF or NM^3 .

The ES-747 can be programmed to calculate the mass flow of gas using the same inputs.

The ES-747 can provide displays of mass flow, heat flow, mass total, heat total, pressure, temperature, specific volume and specific enthalpy.

Pulse, analog, relay and RS232 outputs are provided as well as a 5, 12 or 24vdc@100mA power supply for powering all process transmitters.

Application Terminal Connections

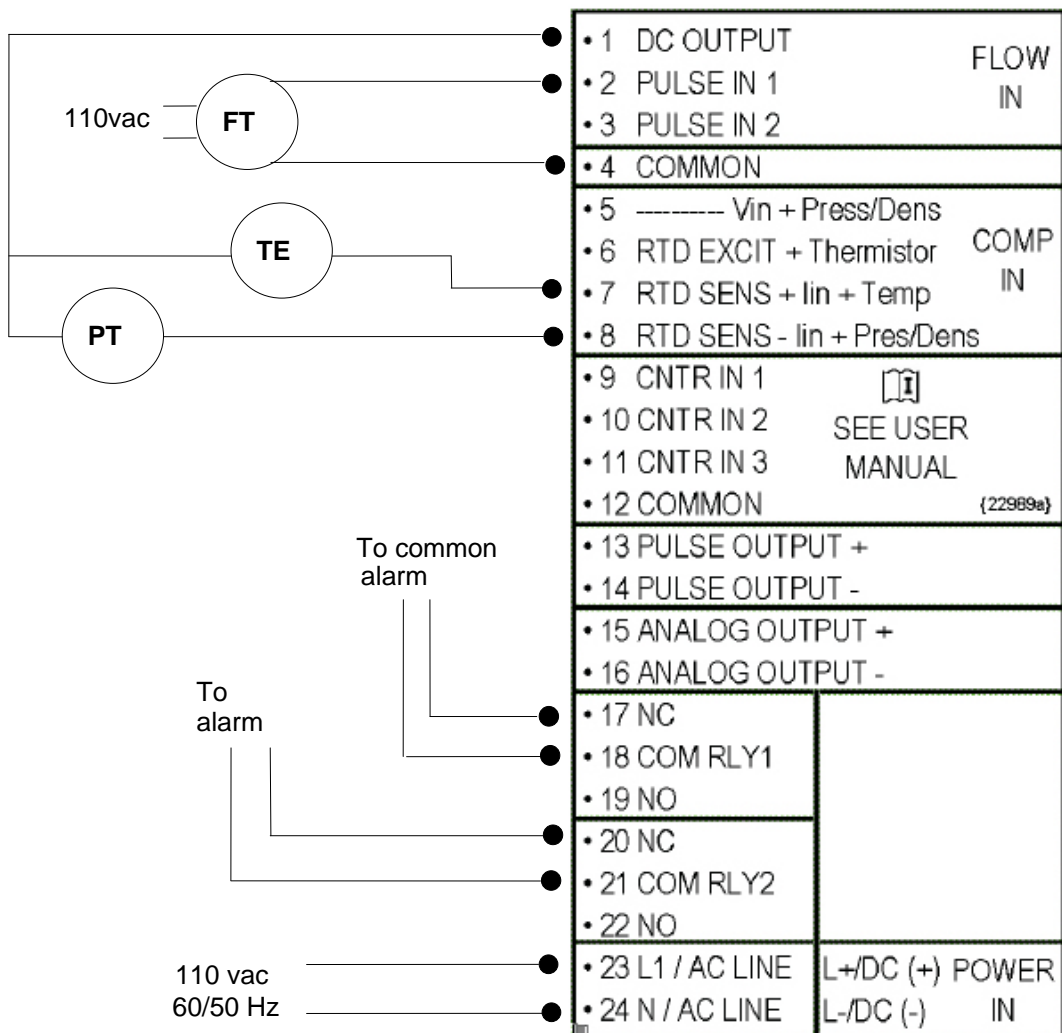

See application notes 20 and 21 for an explanation of the equations relevant to this application.